



International Organization for Standardization
Organisation internationale de normalisation
Международная организация по стандартизации

**ISO Committee
on consumer policy
(COPOLCO)**

38th meeting

Geneva, Switzerland
17 June 2016

Working documents



International Organization for Standardization
Organisation internationale de normalisation
Международная организация по стандартизации

AGENDA ITEM 1 WELCOME AND OPENING OF THE MEETING



International Organization for Standardization
Organisation internationale de normalisation
Международная организация по стандартизации

AGENDA ITEM 2 ADOPTION OF THE AGENDA



DRAFT AGENDA FOR THE 38TH MEETING OF COPOLCO

17 June 2016 – Mövenpick Hotel, Geneva, Switzerland, starting at 9:00

Item	Document	Action*	Rapporteur
1. Welcome and opening of the meeting	-	N	R. Nadarajan, SNV representative, K. McKinley
2. Adoption of the agenda	N203	C	R. Nadarajan
3. Key developments across ISO: <ul style="list-style-type: none"> • Strategies and programmes • TMB – issues/updates on standards development environment and stakeholder engagement • DEVCO/Academy – events • CASCO – issues and events 	Oral report	C	O. Peyrat
4. Tabling of the minutes of the 37th COPOLCO meeting held in Geneva on 14 May 2015	N184	C	R. Nadarajan
5. Chair's and Secretary's reports on items not otherwise covered in the agenda	N204	C	R. Nadarajan D.Kissinger-Matray
New work items and issues – general matters			
6. Raising the profile of consumer interests in the ISO system (awareness and capacity building)	N205	D	R. Devi Nadarajan D. Kissinger-Matray
7. Strategy implementation for ISO/COPOLCO	N206	D	R. Devi Nadarajan
8. 2016 workshop – Results and follow-up actions	N207	D	R. Nadarajan K. McKinley
9. Consumer priorities in standardization on services	N208	D	A. Pindar Liu Chengyang
New work items and issues – working groups			
10. Revision of ISO/IEC Guide 76	N209	D	A. Pindar Liu Chengyang
11. Key areas working group	N210	D	M. Murvold T. Nakakuki
12. Consumer protection in the global marketplace working group	N211	D	B. Dee
13. Product safety working group	N212	D	K. Both E. Moon
14. Consumer participation and training group	N213	D	S. Homer G. Zucal
15. Revision of ISO/IEC Guides 14 and 41	N214	D	S. Herrera, C. Heemsker D. Kissinger-Matray

* Action needed: N = note, C = comment, D = discussion/decision

Item	Document	Action*	Rapporteur	
16. Reports from liaison organizations and regional initiatives				
16.1	International Electrotechnical Commission	N215 (Revised version)	N	J. Bleeker
16.2	Activities of Consumers International with respect to standardization	N216	N	S. Homer
16.3	Recent activities of the Organisation for Economic Co-operation and Development (OECD) - Committee on Consumer Policy (CCP)	N217	N	TBC
16.4	Developments of consumer interest in European standardization: Report by an ANEC representative	N218	N	A. Pindar
16.5	Developments of consumer interest in the Asia-Pacific: Report by a representative of the Asia-Pacific members of COPOLCO	N219	N	R. Nadarajan
16.6	Developments of consumer interest in the Latin American region: report by a representative of COPANT CT 153	Oral report	N	G. Zucal
16.7	Developments in the African region (ARSO)	Oral report	N	TBC
17. Written reports to note from other ISO bodies of consumer interest				
17.1	Conformity assessment (CASCO)	N220	N	<i>To note</i>
17.2	Developing country matters (DEVCO)	N221	N	<i>To note</i>
18.	Any other business next meetings and events of interest including Chair's Group meetings	Oral report	C	R. Nadarajan

* Action needed: N = note, C = comment, D = discussion/decision



International Organization for Standardization
Organisation internationale de normalisation
Международная организация по стандартизации

AGENDA ITEM 3 KEY DEVELOPMENTS ACROSS ISO



**AGENDA ITEM 4 TABLING OF THE MINUTES OF THE 37TH COPOLCO
MEETING HELD IN GENEVA ON 14 MAY 2015**

CONFIRMED MINUTES OF THE 37th COPOLCO PLENARY

ISO/COPOLCO N 184

14 May 2015, Geneva (Switzerland)

COPOLCO Chair	Ms Nadarajan Ratna Devi
ISO Deputy Secretary-General	Mr McKinley Kevin
ISO Vice-President, Finance	Mr Peyrat Olivier

Members

Argentina	Mr	Zucal	Guillermo	IRAM
Australia	Ms	Alison	Scotland	SA
	Mr	Dee	Bill	SA, Compliance solutions
	Mr	Easton	Robyn	Consumers Federation of Australia
	Mr	Furbank	John	Consumers Federation of Australia
Botswana	Ms	Mpho Lucas	Polly	Ministry of Trade and Industry
Brazil	Mr	Amorim	Carlos	ABNT
	Ms	Romano	Thalita	ABNT
Canada	Ms	Bank	Jeanne	SCC
	Mr	Dulmage	Rae	SCC, ULC Standards
	Ms	Ersoy	Suzanna	SCC
	Ms	Islic	Nicki	SCC
	Mr	Kingston	Darryl	SCC
	Ms	McCormick	Norma	SCC
	Ms	Simpson	Christine	SCC
Chile	Ms	Lopez	Marly	INN
	Ms	Leiva	Maria	INN
			Christina	
China	Ms	Cao	Lili	CNIS, SAC
	Ms	Liu	Chengyang	SAC
	Ms	Liu	Xia	CNIS, SAC
	Mr	Zhang	Wei	CAS
Colombia	Ms	Herrera	Sandra	INCONTEC
Cyprus	Mr	Rossides	Stamatis	CYS
Czech Republic	Mr	Dupal	Libor	SCS
	Ms	Pekova	Andrea	UNMZ

Denmark	Ms	Agger	Maibritt	DS
Finland	Ms	Jakosvo	Katri	The Consumer Union of Finland
France	Ms Mr	Coly-Dufourt Reuss	Ludivine Rémi	ALLDC AFNOR
Germany	Ms	Both	Karin	DIN
Indonesia	Mr Mr Ms Ms Ms Ms	Anas Metrauida Ningrum Sudardjat Hilman Komala	Arief Tunus Sukma Ilyani Muti Sophira Dewi Odjar Ratna	Coordinating Ministry for Economic Affairs BSN Coordinating Ministry for Economic Affairs YILKI BSN BSN
Israel	Mr	Peleg	Ehud	SII, Israel Consumer Council
Italy	Ms	Mocchio	Elena	UNI
Japan	Ms Mr Mr Ms Mr	Kawamura Matsumoto Nakakuki Suzuki Yamashiro	Makiko Tsuneo Takashi Takako Jo	Shufuren JISC JSA JSA JISC
Kenya	Ms	Awuor	Celine	CIN
Korea	Ms Ms Ms	Kim Moon Song	Jaiok Eunsook Vokyung	KATS KATS KATS
Lithuania	Ms	Armanaviciene	Alvita	LNCF
Malawi	Mr	Gwaza	Moses	MBS
Malaysia	Mr Mr Mr Ms	Nadason Awang Abd Manaf Mohd Noor	Marimuthu Mat Pauzi Fairus Ainal Fatiha	DSM MDTCC EC DSMC
Moldova	Ms	Pislari	Anastasia	INS
Morocco	Ms	Akarif	Fatiha	IMANOR
Myanmar	Mr	Han	Cho Min	MSTRD
Namibia	Mr Ms	Gaseweb Jacobs	Ernst Michael Rozina	NSI NSI
Netherlands	Ms	Dijkstra	Jelte	NEN
Norway	Ms	Murvold	Merete H.	SN

	Ms	Varland	Elisabeth	SN
Singapore	Mr	Seah	Seng Choon	SPRING SG/ CASE
South Africa	Mr	Manaka	Abner	SABS
	Ms	Monyanga	Emmah	National Regulator for Compulsory Specifications
Sweden	Mr	Henriksson	Jens	The Swedish Consumers' Association SIS
	Ms	Söderberg	Kerstin	SIS
Switzerland	Mr	Hilty	Robert	SNV
	Mr	Maurer	Benno	SNV
	Mr	Vögele	Jean-Marc	Head of FCAB
Thailand	Ms	Kulsalanon	Siripen	TISI
	Ms	Klum-Em	Nopporn	TISI
Uganda	Mr	Richard	Kimera	CONSENT
United Kingdom	Ms	Ferguson	Anne	BSI
	Ms	Heemskerk	Christine	BSI
	Ms	Metham	Sue	BSI
	Mr	Shuker	Jim	BSI
	Mr	Lewis	Keith	BSI
USA	Ms	Thuner	Kathleen	ANSI
	Ms	Greenberg	Sally	

International / Regional organizations

ANEC	Mr	Pindar	Arnold
	Ms	Giovannini	Chiara
	Mr	Eisenegger	Peter
CI	Ms	Homer	Sadie
OECD	Mr	Jackson	Jay

ISO Central Secretariat

ISO/CS	Ms	Kissinger-Matray	Dana	Secretary of COPOLCO
	Ms	Emorine	Madeleine	COPOLCO Secretariat
	Ms	Wolf	Esther	COPOLCO Secretariat
ISO/CASCO	Mr	Hallenbeck	Lane	CASCO Chair

ITEM 1 OPENING OF THE MEETING

1. The COPOLCO Chair welcomed delegates to the 37th COPOLCO plenary.
2. Olivier Peyrat (ISO Vice President, Finance) thanked the Chair and everyone who helped to prepare the COPOLCO plenary and related events. He welcomed delegates stating he would provide follow-up information on commitments made at the 2014 plenary in Milan. ISO President's Committee pays a lot of attention to involving different stakeholders in standardization; COPOLCO is important as it mirrors trends from around the world and includes the consumer as stakeholder in standardization.
3. Robert Hilty (SNV) thanked the Chair and Oliver Peyrat, warmly welcoming delegates on behalf of SNV. He highlighted the importance of COPOLCO's work as standards are increasingly important in legislation, and consumers need to be represented.
4. COPOLCO passed Resolution 1/2015.

COPOLCO Resolution 1/2015

ISO Strategy consultation

COPOLCO

notes the development of the ISO Strategy 2016-2020, and its planned completion in September 2015,

approves the development of a corresponding COPOLCO strategy to support the aims and priorities of the ISO Strategy 2016-2020, as appearing in COPOLCO 10/2015,

notes comments made during the meeting about consumer participation in standards work at the national and international levels,

requests the COPOLCO Chair's Group and the Consumer participation and training working group to:

- *consider how to apply COPOLCO's Terms of Reference to support consumers' interests in standards,*
- *develop further guidance to help consumer representatives be effective in representing consumers' interests in their relevant areas,*
- *propose a programme at the ISO General Assembly to promote the advantages of consumer representatives' participation, based on the principle of balanced stakeholder participation, to CEOs of National Standards Bodies attending the GA; and*
- *work with the ISO Central Secretariat to consider the feasibility of approaching donor agencies to fund participation of consumer representatives in targeted technical areas.*

ITEM 2 ADOPTION OF THE AGENDA

5. The Chair proposed the following changes:
 - Ismail Albaidhani (ISO Academy) would join the plenary via WebEx directly after lunch to introduce ISO Academy's work;
 - Arnold Pindar (United Kingdom) would present the Working Group on Services report;
 - Darryl Kingston (Canada) would present the PASC report, deputizing for Steven Cornish.

6. The agenda was adopted with these changes.

ITEM 3 KEY DEVELOPMENTS ACROSS ISO

7. Olivier Peyrat introduced the key developments across ISO. After mentioning the fruitful workshop on 13 May, *The connected consumer in 2020 – Empowerment through standards*, he mentioned his follow-up of the concern raised at the COPOLCO plenary meeting in Milan in 2014: that the term 'consumer' was not explicitly mentioned in the draft ISO Strategy for 2016-2020. Olivier Peyrat forwarded this concern to the President's Committee, and the term was now included in the new draft.

8. He reaffirmed COPOLCO's role as the worldwide voice of consumers in standards at the international policy level. The challenge is to get input in standardization from consumer representatives at national level, and these representatives need basic technical knowledge, as well as the ability to articulate consumer expectations. Consumer organizations need to find the interface between policy, standardization work, and consumers' expectations.

9. Finally, Olivier Peyrat evoked an earlier discussion by the President's Committee on the importance of consumers as stakeholders in standardization for building a sustainable world together, achievable through various outreach methods such as the internet and volunteers. It involved balancing industry's and the consumers' interests in standardization, as well as the use of standards in regulation, which in turn could guarantee regulations are always up to date and compatible with citizen's expectations.

ITEM 4 MINUTES OF THE 36TH COPOLCO MEETING IN MILAN

10. The minutes were accepted as tabled.

ITEM 5 CHAIR AND SECRETARY'S REPORTS

11. The Chair, Ratna Devi Nadarajan referred to COPOLCO 09/2015 and her attendance of CASCO STAR and CCP meetings. These addressed, inter alia, issues with the Terms of Reference of CASCO and COPOLCO on ethical labelling, as well as other labelling and certification issues. The Technical Interface Group of ISO/CASCO will take it up. The Chair is looking forward to working with CASCO on these issues.

12. In addition, capacity building activities for mirror committees of CASCO at the national level to enable stakeholder participation were discussed.

13. The Secretary, Dana Kissinger-Matray updated the Secretary's report. COPOLCO currently has 123 members, of which 70 are P- and 53 are O-members. Two new P-members, Costa Rica and Namibia were warmly welcomed.

The TMB recently decided not to enforce the membership downgrade requirement in the ISO/IEC Directives for the vote on ISO/IEC Draft Guide 50. She also announced plans for several joint trainings between COPOLCO and the ISO Academy in 2015. One had just taken place on 11 May 2015.

NEW WORK ITEMS AND ISSUES – GENERAL MATTERS

ITEM 6 ISO STRATEGIES 2016-2020: OUTCOMES AND PERSPECTIVES

COPOLCO strategy development, new work programme and yearly implementation model

14. Kevin McKinley, ISO Deputy Secretary-General, introduced ISO's draft Strategy 2016-2020 (COPOLCO 10/2015), and COPOLCO's input.

15. One of the Council's standing committees, the Strategy and Policy Committee, ensures the implementation of ISO Strategy and helps formulate ISO's strategic directions. He emphasized the open and transparent development process; incorporating the needs and interests of all stakeholders.

16. Over 90 ISO members commented, using feedback and ideas from national stakeholders on how ISO's future should be shaped. COPOLCO, TMB, and CASCO also gave feedback on the strategic plan, along with regional and international organizations such as CI, IFAN and other global players.

17. The Council SPC identified broad areas of convergence, and debated divergences such as the role of the Central Secretariat in helping ISO members. The SPC has since consulted with the Technical and the Council Standing Committee on Finance.

18. COPOLCO gave the following main recommendations:

- Enhancing member body commitment to stakeholder participation;
- Enforcing stakeholder participation through supporting technologies;
- Stating the term 'consumer' explicitly in each of its three sections;
- Reinforcing networks and members' capacity, especially developing countries;
- Clarifying language and intent of standards;
- Boosting capacity building, awareness raising, and credibility of processes and products.

19. Kevin McKinley emphasized ISO faces many new challenges: technological, economic, legal, environmental, societal and political. Two major risks and opportunities are stakeholder engagement and ISO's intellectual property. The final aim is that ISO standards are used everywhere. This is based on the three pillars of developing people and organizations, making use of technology, and improved communication. These pillars themselves are built on the core business of ISO: engaging with stakeholders and partners and high quality standards processes through ISO's global membership.

20. Specific plans and actions for developing countries, technical management, and policy areas such as consumers and conformity assessment – and management of ISO's resources – are being prepared. Set indicators will measure ISO's performance implementing its strategy, and a guide on 'setting priority achievements and objectives to ensure the success of ISO in 2020 and beyond' will be published.

21. The next steps for strategy development are:

- Finalize the document based on an April 20th Council WebEx session (by end of May 2015);

- Develop material on background of development of the new strategy;
- Provide updates at relevant meetings of regional standards organizations (eg PASC, COPANT, CEN);
- Hold WebEx information sessions for ISO members (June-July 2015);
- Present the document at ISO's General Assembly in Korea, in September 2015, for approval;
- Have CSC/SPC develop metrics to measure where we are now, and help monitor the new strategy's implementation.

22. Oliver Peyrat clarified that ISO needs to be aware of members' different levels of access to new technologies, and that this should not become a barrier to engagement by developing countries.

23. The following issues and questions were discussed:

Improving regional connections:

- ISO's Singapore office was piloted to improve the connection between members and other stakeholders in the region, and improve the visibility of ISO standards. The Pacific Area Standards Congress (PASC) expressed strong regional support for this office and ISO has received positive feedback so far. If successful, this can be replicated in other regions. ISO Academy will complement this by increasing regional training events.

ISO Strategy consultation:

- Appreciation for consulting CI on the ISO Strategy and for responding to CI's strategic plan. Avoid confusion between the terms 'consumers' and 'consumer representation', as they are not interchangeable.
- Seeing the development of standards on 'social responsibility' or 'quality management', should elements of business ethics can be featured in the new strategic plan, too? The response lay in developing adequate standards for global challenges and reinforcing ISO's code of ethics as part of the system.
- The new strategy is an important opportunity for stakeholder engagement from consumers and ISO Council is open to bringing in all kinds of stakeholders. The consumer plays a vital role in feedback on standards, especially revisions.

Improving consumer representation in ISO's technical committees:

- While information in the Global Directory is becoming more complete, integrating consumer representatives in committees lies primarily with the NSB. In the meantime, ISO TMB will be doing more analysis on improvements that can be made for stakeholder involvement.
- Can ISO's Member Dashboard now give reliable information on consumer stakeholder participation in technical committees as an indicator for achieving the strategic objective of stakeholder representation?
- Consumer representation is often neglected in standardization processes on the national level. The Consumer participation and training working group assists NSBs to manage or develop projects to increase the participation of consumer representatives. But ISO has to do more to promote consumer representation.
- Often funding problems or the political situation in some countries prevents consumers from being represented in standardization work. Thus setting up regional offices is a good idea, as it can facilitate regional cooperation and engagement even without major funding. It is important to increase the profile of the Singapore office and consider a KPI such as the increase in engagement of consumer representatives from the region in standardization.

- The regional office is not intended to replace the interaction between the NSB and its national stakeholders. It was to leverage the potential of the NSB and to facilitate their work.
- Information on stakeholder participation in technical committee working groups and training programmes is still lacking, which prevents effective analysis of efforts to engage consumers in ISO's work. In the United Kingdom the government provides funding for attendance in international meetings for designated stakeholders. Could this be replicated at the international level?
- Funding was a national issue and the answer lay in best practices, such as the proposed funding template of the CP&T working group or soliciting support for consumer representatives from organizations not directly participating in the process, such as insurance companies.
- Consumer organizations should not be allowed to take funding from industry, to guarantee objectivity and their legal status as consumer representatives. However, that cuts funding sources, which leads to a lack of consumer participation.
- Developing countries face difficulty in engaging consumers in the standardization process, eg in Indonesia, in spite of the NSB's efforts. The following was necessary: more education and information on standards development, the role and value of the consumer in this process, training for consumer representatives on how they can influence standardization. Training efforts by ISO/COPOLCO and ISO Academy were also helpful and appreciated.
- The NSB is the key actor in engaging consumer representatives on the national level and ISO Academy is taking a more active role in this process to support NSBs.
- TCs in Cyprus always have one member from a consumer representation organization but this work is voluntary.
- Can ISO support NSBs by helping to connect funders and organizations looking for funds and sharing best practices from other organizations such as the World Bank and the European Union?
- A best-practices session concerning funding could take place at a future COPOLCO meeting.

24. The Chair proposed that the Chair's Group and the Consumer participation and training group apply COPOLCO's terms of reference to increase consumers' work in TCs. Furthermore, the chair invited participants to consider how ISO/IEC Guides can help consumer representatives to get engaged in highly technical standardization work and to explore whether the DEVCO meeting could include an item on assisting NSBs with promoting balanced stakeholder engagement in at least the policy committees. Finally, she suggested the ISO Central Secretariat explore ways donor funded projects can include supporting NSBs to increase consumer participation.

ITEM 7 COPOLCO'S VISIBILITY AND ADDED VALUE TO MEMBERS

25. The Chair introduced COPOLCO 11/2015. The aim, enhancing COPOLCO's visibility among ISO members, is a result of discussions at the 2014 GA. NSB CEOs did not see the value of ISO COPOLCO and its results trickling down to the national level. Therefore the Chair proposed circulating a questionnaire to evaluate the current situation. She invited the members to provide feedback on the draft questionnaire.

26. Participants made the following suggestions:

- Reduce unnecessary abbreviations
- Provide more answer alternatives, especially for questions two and four
- Follow up on the ISO Strategy
- COPOLCO should develop a work programme based on ISO's strategy, consumer

- interest, and its terms of reference.
- Evaluate the plenary and related events on completion of COPOLCO's visibility and value to member states.
 - Change question 5 from "Do you have a national mirror committee of COPOLCO?" to: "Do you have a national consumer committee where you discuss COPOLCO issues?"
 - Reconsider the use of the term "mirror committee" to include different methods of national consultation.
 - Focus on showing specific impact COPOLCO has had on the national level.
 - Ask respondents to consider all deliverables COPOLCO has developed and evaluate their implementation at the national level.
 - Specify "visibility" to mean "visibility within the ISO system", i.e. Technical Programme Managers and committee experts.

ACTION ITEMS:

- Set up an action plan to increase COPOLCO's visibility within ISO (Chair and Secretary)
- Send the revised questionnaire to NSBs and some TCs
- Generally to increase communication to all stakeholders of the ISO community about the impact of COPOLCO's work (Chair and Secretary, COPOLCO CG, CP &T).

COPOLCO Resolution 2/2015

COPOLCO's visibility and impact to members

COPOLCO

notes the report of the COPOLCO Chair appearing at COPOLCO 11/2015,

approves the recommendations proposed in the report, with addition of comments made at the meeting.

ITEM 8 REVISION OF ISO/IEC GUIDES – REVIEW OF CURRENT PROJECTS AND FOLLOW-UP ACTIONS

27. The Secretary provided an update on COPOLCO 12/2015. There has been progress in the work of the revision of several guides. The majority of ISO/IEC Guides are also free of charge for [download from iso.org](http://www.iso.org). This was part of a TMB decision to recognize that ISO/IEC Guides have been undervalued and under-promoted within the ISO system and are not well known. The TMB has been very supportive in this matter.

28. The Secretary mentioned the revision of ISO/IEC Guide 14, *Purchase information on goods and services intended for consumers*. The working group, led by convener Michelle Altoff has prepared a committee draft nearly ready for Committee Internal Ballot consultation.

29. The COPOLCO Chair has convened the group developing ISO/IEC Guide 46, *Comparative testing of consumer products and related services – General principles*. A Draft Guide enquiry would be launched soon and members were encouraged to coordinate at the national level and vote on the enquiry.

30. Finally, the Secretary mentioned the published revisions of important ISO/IEC Guides, such as Guide 50, *Safety aspects – Guidelines for child safety in standards and other specifications*;

Guide 51 on *Safety aspects – Guidelines for their inclusion in standards*; and one developed through cooperation between ISO, IEC and ITU: Guide 71, *Guide for addressing accessibility in standards*.

31. The ANSI delegation conveyed a remark from Michelle Althoff that the working group was pleased with the progress revising Guide 14 to bring greater clarity, continuity, and global consensus on robust types of product information with a benefit for consumers.

ITEM 9 STANDARDIZATION OF SERVICES – CONSUMER ISSUES

32. Arnold Pindar (BSI, ANEC) referred to COPOLCO 13/2015 in thanking the group Co-Chair, Liu Chengyang and other colleagues for their work. The systematic review consultation for ISO/IEC Guide 76 started in October 2014 and ended in March 2015. 13 P-members voted for a revision. The working group noted suggestions to take into account the more recent CEN Guide 15 and its reference to Guide 76. CEN Guide 15's content will therefore be integrated into the revision of ISO/IEC Guide 76. Participants were invited to give feedback on the Guide.

33. The working group will be divided into two sub-groups: one dealing with the wider aspects and more general issues of services standardization, and the other with the Guide 76 revision itself. The next step will be to create a first working draft of ISO/IEC Guide 76, before the next meeting of the Chair's Group.

34. The services working group will survey existing standards at the national or regional level, for a gap analysis. They will also gather case studies on consumer issues in services for evaluation.

35. Delegates offered the following comments:

- There is some overlap between the working group on consumer issues in services and the consumer protection in the global market place working group; it is necessary not to confuse the scopes of the two working groups;
- The Chair's Group can supervise the two working groups to prevent confusion;
- Why is the Guide planned for publication in 2017?
- A four year work plan allows time for controversial discussions, but the working group will try to publish the Guide earlier.

COPOLCO Resolution 3/2015

Consumer issues in standardization of services (1)

COPOLCO

approves the proposed Terms of Reference of ISO/COPOLCO working group 18, Consumers' issues in standardization of services, appearing in COPOLCO 13/2015.

COPOLCO Resolution 4/2015

Consumer issues in standardization of services (2)

COPOLCO

notes the results of the systematic review and report appearing at Annexes 3 and 4 to COPOLCO 13/2015, further notes comments made at the meeting,

decides to revise ISO/IEC Guide 76, Development of service standards – Recommendations for addressing consumer issues,
invites COPOLCO WG 18 to start revision work on the Guide.

ITEM 10 2015 WORKSHOP – RESULTS AND FOLLOW-UP ACTIONS

WORKSHOP RESULTS

36. Rémi Reuss (AFNOR) and Alison Scotland (SA) summarized the workshop of 13 May 2015, *The Connected Consumer in 2020: Empowerment through Standards*. The main question was whether standards can help protect consumer data privacy in an environment of innovative business practices, big data and the Internet of Things (IoT), and if so, how. Presentations were made in the morning, followed by two group discussions in the afternoon.

37. The first discussions generated as main themes:

- Consumers' right to opt in and out (with a preference for a default opt out) and the possibility to stop data being recorded;
- The right for data to be forgotten/erased after a certain time;
- The right to know how/where information is stored, controlled – what for, and how long;
- The right for consumers to change their minds;
- The “quantified world” and the perception that nobody will have privacy in future;
- Financial cost to protect your privacy, rather than privacy as a default (potentially creating a split society);
- Needed gap analysis of existing standards and other infrastructure;
- Need for participation in IEC, and equally for IEC to participate in COPOLCO;
- Respect the freedom of choice for consumers;
- Different levels and preferences for data access;
- Worker protection vs. worker privacy rights.

38. During the second round of table discussions the following actions for COPOLCO were recommended:

- Promote greater interaction between COPOLCO, IEC & ITU / ISO-IEC JTC 1;
- Encourage industry to have a code of conduct on privacy (could be included in a guide?);
- Raise awareness and educate consumers, especially in developing countries;
- Recognize the need to train technical experts on consumer privacy issues;
- Lead a gap analysis to identify all privacy related standards, guidelines, and other supporting documentation, then determine what is not covered / not known;
- Ensure privacy by design guidelines are incorporated into ISO/IEC, not just BSI;
- Create a code of practice for collective data; including the right to be forgotten;
- Bring a template for wearable computing through to CAG;
- (Re)define privacy.

39. Finally, Alison Scotland presented workshop conclusions: Norma McCormick, chairing the discussion sessions, highlighted the similarities between the product safety issue years ago and

privacy now. We have to identify security and/or privacy risk, use understanding of risk and formalize it, share it and make sure people can act on it, develop easy-to-understand user guide(s). The importance of educating young people or vulnerable consumers, prevention and protection, training technical experts to understand consumer issues, and prevention of victimization were emphasized. Consumers can position themselves away from being vulnerable and become empowered to ask questions, protect themselves and others, and solve problems.

Secretary's note: The workshop summary and presentations are available on ISO.org.

40. Comments from the floor were:

- Include privacy by design in the ISO/IEC Directives;
- About 2-3 years ago, BSI experts spend 6 months trying to define the term 'privacy', and they were not successful. Privacy is a complex term, especially real time dynamic privacy control;
- Lack of an industry code of conduct makes educating the consumer even more crucial;
- Consider use of standards for self-regulation in a sharing economy and examine impacts on privacy;
- The Global Marketplace working group could address three issues: the gap analysis for privacy, collaborative economy issues not covered in the privacy or the business-to-consumer information realms, and new trends in wearable computing;
- Identify existing standards that can be used by regulators in order to protect the data and privacy of consumers;
- There are big differences in national levels of standardization and regulation, therefore it might be difficult for COPOLCO to identify if existing standards can be used for regulation purposes and if they are suitable to cover national gaps;
- An [ISO/IEC brochure and resources on referencing standards in regulation](#) exists, and a workshop on how to use standards to support regulation will take place on 2-3 November 2015 in Geneva;
- After the gap analysis, a proposal to develop guidance for consumer representatives would be helpful to support consumer representatives' work raise consumers' awareness of privacy issues;
- For mobile banking, some national governments use standards to develop national legislation or regulation;
- Many consumers in developing countries are not 'connected consumers' yet and won't be by 2020. This can lead to low awareness of privacy issues that can arise for the 'connected consumer'. It is necessary to share findings with consumers, governments and regulators so they will be able to handle technological developments in their countries;
- Technical progress is rapid: consumers who are not 'connected' yet will be soon. Thus, we need to act now, so 'connected consumers' of tomorrow are prepared;
- A gap analysis should look at existing standards committees dealing with IT and assess if it is possible to incorporate a 'blocking' ability for consumers to protect their own privacy;
- CYS (Cyprus) provides free education on consumer protection, including privacy and new technologies; and educates people about standards and related processes;
- An OECD report on the digital economy can be found in the additional working documents; COPOLCO could input on privacy through its liaison with OECD CCP;
- The OECD Guideline addresses e-commerce, rather than privacy. But the OECD sub-committee on the digital economy and regulations might work with COPOLCO on privacy issues. There is also a sub-committee on regulations which might be interested in cooperating with COPOLCO.

FOLLOW UP ACTIONS

41. The Chair summed up the main workshop outcomes:

- The Consumer protection in the global marketplace working group will do a gap analysis of existing standards within ISO, IEC and ISO/IEC JTC1; ITU and UN/ECE on personal privacy – with a view to ensuring privacy issues affecting consumers' interests are adequately dealt with; and to recommend a course of action for ISO to address these issues, for the consideration of the COPOLCO Chair's Group at its next meeting;
- The group will also develop a scoping paper and complete a new activity template based on Dr Kernaghan Webb's presentation and discussions at the COPOLCO 2015 workshop with respect to the collaborative economy and consumer issues;
- In addition, the global marketplace working group will develop a new work item template on wearable computing, to be considered by the Chair's Group at its next meeting;
- The COPOLCO Plenary further noted strong support for the gap analysis expressed by representatives from Kenya and other developing countries to ensure that developing country privacy concerns expressed at the workshop and plenary are factored in;
- COPOLCO invites IEC to participate regularly in COPOLCO's plenary and Chair's Group meetings, and emphasizes the need for ISO to coordinate appropriately with IEC and ITU on issues relating to consumers' personal control in real time over use of personal data;
- The Consumer participation and training group was requested to consider the feasibility of replicating the National Consumer League's model (ANSI-USA) for outreach to young and vulnerable consumers for use in other countries.
- The Chair's Group was invited to consider the feasibility of recommending the incorporation of privacy-by-design principles into the ISO/IEC Directives and to discuss the feasibility of proposing the adoption of standards resulting from the European Commission Mandate on privacy by design, as International Standards.

42. Comments from the floor on the follow-up actions were:

- Privacy standards will probably take considerable time to come into being, but national legislation does not have to wait. Some countries might legislate new technology issues even before a standard is in place.

Secretary's note: The idea of introducing privacy by design in the ISO directives was strongly supported by the plenary.

COPOLCO Resolution 8/2015

2015 workshop, The connected consumer in 2020 – empowerment through standards

COPOLCO

thanks the speakers, facilitators and rapporteurs for their contributions to the 2015 workshop, The connected consumer in 2020 – empowerment through standards, emphasizes the need to adapt business and standardization methods to meet the challenges posed by the rise of the collaborative economy and innovative business models, decides to request the Consumer protection in the global marketplace working group to undertake a gap analysis of existing standards within ISO, IEC and ISO/IEC JTC1, the ITU and UN/ECE on privacy and protection of personal data in order to identify areas needing further work in consumer protection, for the consideration of the COPOLCO Chair's Group at its next meeting in November 2015,

notes strong support for the gap analysis expressed by representatives from Kenya and other developing countries to ensure that developing country privacy concerns are factored into the analysis,

further notes that comments made at the workshop and plenary meeting about privacy will be considered for the gap analysis,

invites IEC representatives to participate regularly in COPOLCO's plenary and Chair's Group meetings,

emphasizes the need for ISO to coordinate appropriately with IEC and ITU on privacy and personal data protection issues, recognizing the need for consumers' dynamic, real-time and active control over use of their personal data.

WORK ITEMS AND ISSUES – WORKING GROUPS, FUTURE MEETINGS

ITEM 11 KEY AREAS FOR CONSUMERS WORKING GROUP

43. Merete Murvold (SN) and Takashi Nakakuki (JISC) presented the work in COPOLCO 15/2015.

44. Takashi Nakakuki briefly overviewed the working group's mandate, which is to raise awareness, identify and monitor key areas, and to facilitate networking.

45. Further, he introduced the working group's four deliverables :

- Handbook
- Project Overview
- Report "Standards for consumers – Update"
- List of published consumer standards

46. The key areas for consumers report is now published in a new format under the title "Standards for consumers – Update". It includes highlights for the 29 key areas.

47. Takashi Nakakuki thanked the key persons for contributing their reports. The working group has provided a new list of published consumer standards, available on ISO's website. It has also received a new key area on Unit Pricing, approved for development into an International Standard on 12 February 2015. John Furbank (Standards Australia) will be the key person for this.

48. Merete Murvold encouraged participants to submit proposals for new key areas.

COPOLCO Resolution 5/2015

Key areas for consumers (1)

COPOLCO

thanks Mr. Takashi Nakakuki for his willingness to take the responsibility as co-chair of COPOLCO WG 2 Key areas for consumers,

appoints Mr. Nakakuki as co-chair of this working group.

COPOLCO Resolution 6/2015

Key areas for consumers (2)

COPOLCO

approves unit pricing as a new key area, supporting the newly-established ISO/PC 294, Guidance on unit pricing.

COPOLCO Resolution 7/2015

Key areas for consumers (3)

COPOLCO

thanks the Key areas for consumers working group for its report and annexes appearing at COPOLCO 15/2015,

approves the report "Standards for consumers – Update", project overview, template for new submissions and list of consumer standards published as annexes to COPOLCO 15/2015.

ITEM 12 CONSUMER PARTICIPATION AND TRAINING WORKING GROUP

49. Guillermo Zucal (IRAM) summarised the working group's activity since 2014 (COPOLCO 16/2015). Its last meetings were in November 2014 and May 2015.

50. The group confirmed Sadie Homer's (CI) appointment as co-Chair of the working group, taking over from Anne Ferguson (BSI).

51. Main work includes developing a funding template, training activities, updating ISO's online directory and case studies on consumer participation. Further, the work plan includes guidance for COPOLCO contact persons, and "COPOLCO mirror committees", and a succession task force, to be led by Nicki Islic from SCC (Canada).

52. Guillermo Zucal promoted the training initiative of ISO Academy and COPOLCO, at CI's congress in Brazil on 18-20 November.

Secretary's note: A consumer training event also took place during ARSO's General Assembly in Addis Ababa, Ethiopia, on 14 August.

COPOLCO Resolution 9/2015

Consumer participation and training working group (1)

COPOLCO

thanks the Consumer participation and training working group for its report at COPOLCO 16/2015,

approves its continued activities as outlined in the work plan,

welcomes efforts to re-introduce regional training, particularly for those from developing countries, and

thanks the ISO Academy, trainers, and participants for the successful training session on 11 May 2015.

COPOLCO Resolution 10/2015

Consumer participation and training working group (2)

COPOLCO

notes plans to revise the ISO Directory of consumer participation to disseminate information about activities of the Consumer participation and training group work plan, such as the funding database.

COPOLCO Resolution 11/2015

Consumer participation and training working group (3)

COPOLCO

thanks Caroline Warne for her work in developing new guidance on COPOLCO mirror committees and COPOLCO contact persons,

requests COPOLCO members to encourage consumer participation at the national level,

further requests the consumer participation and training working group to revise the document in light of comments made at the meeting, and recirculate it to the members of COPOLCO,

recommends that, on completion, this guidance be disseminated widely among the COPOLCO membership and included in relevant training sessions.

COPOLCO Resolution 12/2015

Consumer participation and training working group (4)

COPOLCO

thanks the outgoing co-Chair Anne Ferguson (BSI – UK) for her work,

approves the appointment of Sadie Homer (CI) as the new co-chair of the working group.

ITEM 13 PRODUCT SAFETY WORKING GROUP

53. Eunsook Moon (KATS) presented COPOLCO 17/2015. She cited two NWIPs of the working group on product safety:

- ISO/IEC 82079-2: Part 2, *Provisions for instructions for self-assembly products* has been forwarded for IEC/TC 3's consideration. The next step depends on the ballot.
- The NWIP on choking hazards of small component parts was resubmitted to TMB with a suggestion to forward it to TC 122, *Packaging*.

54. A new project is being discussed: General principles for risk management of consumer product safety. The plan is to form a sub-committee and consider a revised draft to be resubmitted for COPOLCO's further consideration .

55. New issues under consideration are:

- Nappy sacks: this issue was forwarded to the group revising ISO/IEC Guide 41, *Packaging – Recommendations for addressing consumer needs*);
- E-cigarettes/Liquitabs washing pods: acknowledged as serious safety issues;
- Lithium button cell batteries: No further work until current international work is concluded;
- 3D or additive printing: Contact ISO/TC 261, *Additive manufacturing* to raise safety concerns;
- Drones: Contact ISO TC 20/SC16, *Aircraft and space vehicles* to raise safety concerns.

COPOLCO Resolution 13/2015

Product safety working group (1)

COPOLCO

approves the report of the Product safety working group (PS WG) at COPOLCO 17/2015, notes the continued input from the PS WG into the revision and promotion of ISO/IEC Guides, further notes the revisions in 2014 of:

- ISO/IEC Guide 50, Safety aspects – Guidelines for child safety in standards and other specifications

- ISO/IEC Guide 51, Safety aspects – Guidelines for their inclusion in standards, and

- ISO/IEC Guide 71, Guide for addressing accessibility in standards;

thanks the Product safety working group members for their contributions in these areas.

COPOLCO Resolution 14/2015

Product safety working group (2)

COPOLCO

notes the submission of the new work item proposals, ISO/IEC 82079-2 Preparation of instructions – Structuring, content and presentation - Part 2 - Provisions for instructions for self-assembly products; and Choking hazards of small component parts to ISO TC 10 for ballot, further notes positive comments, but non-acceptance of these proposals due to an insufficient nomination of experts, and the decision of ISO/TC 10 to forward NWIP ISO/IEC 82079-2 to IEC/TC 3 for further consideration and ballot closing on 7 August 2015.

decides to resubmit the NWIP, Choking hazards of small component parts for consideration by another technical committee, such as ISO/TC 122, Packaging.

COPOLCO Resolution 15/2015

Product safety working group (3)

COPOLCO

thanks the Product safety working group for their scoping document on Quantification of risk assessments, appearing at Annex 1 to COPOLCO 17/2015,

notes comments made on the proposal, and the proposal to appoint a task group to redraft it,

invites the product safety working group to resubmit the draft for further consideration of members,

recognizes the importance of other safety issues presented in COPOLCO 17/2015,

further invites the group to submit a progress report for members' consideration at the 2016 COPOLCO meeting.

COPOLCO Resolution 16/2015

Product safety working group (4)

COPOLCO

thanks ANEC for its report on issues relating to safety of products appearing at COPOLCO 25/2015,

strongly supports ANEC's campaign to delete the exclusion clause from the parent IEC 60335 standards, and other standards for consumer products,

further supports lowering of surface temperature limits in the IEC 60335 series of standards,

invites members with the national representation in IEC/TC 108 to support ANEC on safety issues relating to audio-video equipment.

ITEM 14 CONSUMER PROTECTION IN THE GLOBAL MARKETPLACE WORKING GROUP

56. Bill Dee (SA) presented five initiatives (COPOLCO 18/2015):

- Communicating with consumers: Markets and governance agencies need to re-frame how they deal with consumers. In this context, Mr Dee pointed to the template on business-to-

consumer communication, and the ongoing revision of ISO/IEC Guide 14 *Purchase information on goods and services intended for consumers*. Further, he supported the future conversion of ISO/IEC Guide 14 into an international standard.

- Financial literacy for youth: The proposal still needs to undergo review by the WG and the Chair's Group, and COPOLCO members will be invited to respond to a formal consultation in due course.
- Dealing with consumer vulnerability: BSI's work on consumer vulnerability was noted, and Bill Dee invites members to contact the COPOLCO Secretariat to indicate their interest in participating in any future work in this area.
- Counterfeiting: Outcome from the workshop in Fiji: An education campaign is being developed by ISO/CS, including a kit for members to help run national campaigns focused by theme and on social media.
- Consumer product warranties: DSM (Malaysia) is interested to host the secretariat and provide a project leader for a new PC on consumer warranties.

57. All these initiatives are outcomes of previous workshops, giving them high relevance.

58. Standards under development are:

- Customer contact centres: A working group is currently developing CDs of both parts and aims to circulate them to the PC in time for comments to be resolved at a PC meeting scheduled for September 2015 in South Africa.
- Mobile banking: COPOLCO noted the release of ISO 12812, *Core banking – Mobile financial services* as a Draft International Standard. Members are encouraged to comment.
- For energy services: ISO 50007, *Activities relating to energy services – Guidelines for the assessment and improvement of the service to users*. Bill Dee encouraged consumer participation in developing this standard.

59. Finally he indicated the group would follow up recommendations from the 2015 workshop (see above, Agenda item 10).

60. Bill Dee thanked Anne Ferguson and Jeanne Bank for their dedicated work in consumer protection in the global marketplace.

61. Comments from the floor were:

- TC 68 was forthcoming to consumer representatives and included consumer protection in all documents. All TCs should note COPOLCO is the forum to seek consumer expertise and input for their work.
- A more generic process was needed to identify issues within TCs that need consumer input, to allow consumer representatives to get involved sooner rather than later.
- Support for the projects on Guide 14 and financial literacy, and thanks to the working group.

COPOLCO Resolution 17/2015

Global marketplace working group (1)

COPOLCO

thanks the global marketplace working group for its report at COPOLCO 18/2015,

approves the activity template on business-to-consumer communication appearing at Annex 1 to COPOLCO 18/2015,

notes the ongoing revision of ISO/IEC Guide 14, Purchase information on goods and services intended for consumers,

supports future conversion of ISO/IEC Guide 14 into an International Standard, upon its publication.

COPOLCO Resolution 18/2015

Global marketplace working group (2)

COPOLCO

notes the work of British Standards Institution on consumer vulnerability as described in COPOLCO 18/2015,

invites its members to contact the COPOLCO Secretariat to indicate their interest in participating in any future work in this area,

requests the Secretary to correspond with the members to gather views and information about the interest and relevance of international work on consumer vulnerability.

COPOLCO Resolution 19/2015

Global marketplace working group (3)

COPOLCO

notes the release of ISO 12812, Core Banking – Mobile Financial Services (all parts) as a Draft International Standard,

encourages its members to provide support to comments and votes on the ballot.

SHORT ORAL REPORTS AND DISCUSSION ON POTENTIAL FOR REGIONAL COOPERATION IN TODAY'S ISO

ITEM 15 SHORT ORAL REPORTS AND PANEL DISCUSSION ON THE THEME: "WHAT POTENTIAL IS THERE FOR REGIONAL COOPERATION IN TODAY'S ISO?"

15.1 Developments of consumer interest in European standardization: Report by ANEC representative Arnold Pindar

62. Arnold Pindar (ANEC) said ANEC was able to sign a contract with the European Union at the end of last year, and a second contract with the European Free Trade Association (EFTA). Together these guarantee ANEC's funding for the next 4-6 years.

63. Further, he introduced ANEC's role in the EU-US Transatlantic Trade and Investment Partnership (TTIP), which is supposed to be signed by the end of this year. ANEC is trying to balance differences in standards between the EU and the US. These differences stem from very

divergent standardization processes. Besides standards, there are also conformity assessment and marking issues. More generally, ANEC is defining EU positions on international standardization and these issues. He emphasized the need to look at the implications for consumers stemming from standardization at the international level. So even though globalization is an opportunity for international standardization, ANEC also faces challenges for global consumer protection.

64. Finally, Arnold Pindar also welcomed the mention of consumers in the new draft of ISO's strategy 2016-2020. He felt the strategy needs to make a clear distinction between the terms 'consumer' and 'customer', and to reinforce the participation of consumer representatives in t ISO's standards development process.

65. Arnold Pindar expressed concern that consumer representatives face more difficulties in participating in the process with shorter timeframes.

15.2 Developments of consumer interest in the Asia-Pacific: Report by a representative of the Asia-Pacific members of COPOLCO

1 Asian and Pacific Island Consumer Policy Report 2015 (AP COPOLCO) – Muti Sophira Hilman

66. Muti Sophira Hilman (BSN - Indonesia) presented AP COPOLCO's report. She gave a short overview of the establishment of the organization. It was originally established as ANCO in 2006, but was renamed AP COPOLCO in 2012, after Pacific Island countries joined.

67. AP COPOLCO's mandate is to:

- Raise awareness among consumers, industry, and government of the importance of standards, consumer protection and a sound metrology infrastructure;
- Provide information on activities related to Asian developing and Pacific Island countries' policies on standards, consumer protection and metrology;
- Enhance capacity of different stakeholders to advance standards, consumer protection and sound metrology infrastructure in the Asian developing countries and Pacific Island countries.

68. Furthermore, she gave an update on the working group's activities in the fields of awareness and education, testing, capacity building and research, and assistance from ISO COPOLCO. The overview included Indonesia, Japan, Korea, Malaysia, Thailand and Vietnam.

69. Muti Sophira Hilman (BSN) stated that more information and the full report can be found on the website of the Malaysian Association of Standards Users.

2. Pacific Area Standards Congress – Darryl Kingston

70. Darryl Kingston (SCC) presented the PASC report, deputizing for Steven Cornish (ANSI).

71. He stated that PASC is not a standards development body. Its aim is to strengthen the cooperation between countries of the Pacific region and ISO and IEC. The focus of PASC is to set and establish priorities for the Pacific Region.

72. PASC submitted feedback to the ISO Strategic Plan 2016-2020. Further, PASC sent a letter urging closer collaboration between ISO, IEC and ITU; to reduce overlaps in new emerging ICT areas such as Smart Cities, the Internet of Things (IoT) and Security. There was also collaboration with ISO Technical Committees on PASC's pilot projects.

73. There was cooperation between PASC and ISO in regional capacity building activities. PASC members supported capacity building workshops organized by ISO's Regional Office, and ISO participated in PASC's Workshop on fostering the next generation of leaders in 2014.

74. Darryl Kingston also presented a survey which was launched on consumer standards issues of common interest among countries in the region and for specific countries in the region. Further, he presented concerns for consumer interest participation in national and international standards development of the PASC members.

75. Finally, he presented several possible future areas for PASC's engagement with ISO/COPOLCO, for example; to provide further input for COPOLCO's strategic plan, strengthening cooperation with ISO's regional office, and identify and communicate regional priorities. ISO could assist PASC in promoting NWIPs, capacity building activities, undertaking consumer safety projects with APEC SCSC and other regional bodies; and in its dialogue with consumers on the use of standards.

15.3. Developments of consumer interest in the Latin American region – Guillermo Zucal, a representative of COPANT CT 153

76. Guillermo Zucal (IRAM) presented the 17 member countries and their specific interests and capacities in standardization work, especially in consumer representation.

77. The most important activities of COPANT CT 153 were:

- IRAM's Consumer Committee achieved high participation in different TCs;
- Agreement IDEC – ABNT (Brazil), CPCON Standard Committee on Consumer Standards were actively engaged in campaigns on the news, TV, and social media;
- Norma Cubana (Cuba) adopted COPOLCO Guides (37, 59, 51, 64, 71, and 76) and participated as an NSB in the development of consumer protection law;
- INDECOPI (Peru) – Comité técnico de normalización (CTN) de políticas des consumidor has translated and adopted ISO/COPOLCO Guides, launched surveys, and run campaigns;
- ICONTEC (Colombia) – NTC 198 – Consumers work for the adoption of ISO/IEC Guides and public discussions;
- INN (Chile) – the National Mirror Committee and National Consumers Committee have been working on product safety;
- SCC Connect (Canada) has a consumer interest panel; a workshop will be held in June.

78. The Secretary noted that regional organizations and coordination bodies mirror the concerns of ISO COPOLCO, for example regarding the Internet of Things and coordination between ISO, ITU and IEC. Could regional organizations be the future or driver of ISO?

79. Mr Kingston (SCC): Regional groups are identifying regional needs and fields that ISO should further explore. Regional organizations will not replace ISO; their work is complementary.

80. Arnold Pindar (ANEC): On the European level, ANEC is working in a legislative framework. The big and important issues today are of global nature – which makes it necessary to increase

cooperation between all geographical areas and levels of organization. There could be a driver for one or two specific areas. But as a whole everyone, also minor stakeholders; particularly consumers; need to be integrated into the process. Regional organizations will not replace ISO but will have to work more closely with it.

81. Kimera Henry Richard (UNBS – Uganda): asked whether it would be possible to include the African region in the plenary to report back on regional developments in 2016. The Chair responded that a channel would be established with the African Organization for Standardization's Consumer Committee (ARSO COCO) to report to COPOLCO's next plenary.

INFORMATION ITEMS

ITEM 16 ACTIVITIES OF CONSUMER INTEREST WITHIN LIAISON ORGANIZATIONS

16.1. Consumers International – Sadie Homer

82. In her report at COPOLCO 19/2015, Sadie Homer indicated that CI's Congress would be on 18-21 November in Brasilia. More information will be sent to COPOLCO members, and can be found on the CI website. She thanked ISO Academy and SIDA for sponsoring a number of CI members from developing countries.

83. The training on Monday, 11th of May contributed well to bringing in voices from developing countries. Ms Homer was looking forward to the training in November, as a side event of the CI Congress. She stressed CI's website provides ample information on their work.

16.2. Recent activities of the Organization for Economic Cooperation and Development (OECD) Committee on Consumer Policy (CCP) – Jay Jackson

84. Jay Jackson (OECD CCP) gave an update following a big meeting in April. The OECD CCP will host the OECD ministerial meeting on the digital economy in Mexico on 22-23 June 2016, on the theme, *The digital economy, innovation, growth, and social prosperity – Protecting consumers in the sharing economy*. The conference will look at the interaction between sharing economy activities and existing consumer protection frameworks. It will examine such issues as:

- Which reputation initiatives best build trust among peers?
- What level of responsibility should be borne by business platforms?
- What is the extent of sharing activities?

85. The Federal Trade Commission is having a consultation and a one day workshop on ['The sharing economy' on 9 June 2015 in Washington](#). Jay Jackson added the OECD CCP just released a report on industry self-regulation which includes references to ISO and ISO COPOLCO.

WRITTEN REPORTS TO NOTE

ITEM 17 ACTIVITIES OF CONSUMER INTEREST UNDER ISO AND IEC BODIES OTHER THAN COPOLCO

17.1. CASCO

86. The Chair of CASCO, Lane Hallenbeck, emphasized the huge overlap of issues discussed by COPOLCO and CASCO (see COPOLCO 22/2015). They evolve all around optimizing trust between buyers and sellers. CASCO works on defining the bridge between standards and conformity assessment for the whole supply chain, of which the last and most important point is the end consumer.

87. A main focus of CASCO was to increase the inclusiveness and participation of its members by holding meetings all over the world (and not only in Geneva). CASCO organized a workshop and plenary meeting last fall with the title, *Opportunities, challenges and priorities*. The next plenary in spring 2016 will be in the United Arab Emirates and in 2017 in Canada. Mr Hallenbeck proposed to connect CASCO and COPOLCO in a workshop or to coordinate the scheduling of plenary meetings in future.

88. Policy committee meetings were held by AENOR in Madrid this year. Standards for the service sector, and privacy issues, are increasingly important. Further topics discussed were: validation and verification in conformity assessment methods, the STAR group on outreach to stakeholders, the new online tool for regulators, work on creating a stakeholder forum in 2016, ethical and other labelling, composition of committees and working groups, the meeting of the working group on accreditation bodies, and developing national mirror committees.

89. At the end of the year, CASCO plans to organize a workshop on conformity assessment with the World Standards Cooperation. COPOLCO members are invited to attend.

90. Currently, three-quarters of ISO members are also CASCO members. Lane Hallenbeck wants to increase this in future.

91. Lane Hallenbeck stated CASCO's toolbox of conformity assessment documents has evolved from Guides to International Standards.

92. CASCO also gave feedback on ISO Strategy.

93. Lane Hallenbeck mentioned funding is always an area of concern for CASCO.

94. Franck Mmakgabo from the South African Bureau of Standards will succeed Lane Hallenbeck as Chair of CASCO in 2016.

17.3 Developing country matters (ISO Academy)

95. Ismail Albaidhani (Director of the ISO Academy) welcomed the delegates and thanked the Chair. He congratulated participants of the training, jointly organized by ISO Academy and COPOLCO.

96. He indicated the Action Plan for Developing Countries is a strategic framework which ISO produces every four years to structure activities to assist developing countries around the world. The current plan ends this year, and the new plan for 2016-2020 has been drafted. DEVCO CAG members drafted impact areas, shared with ISO members, who were encouraged to reach out and contact national stakeholders for feedback. The new APDC mentions the importance of consumers and their involvement – an improvement on the last strategic plan.

97. Dr Albaidhani encouraged participants to comment the APDC.

ITEM 18 ANY OTHER BUSINESS

98. The Secretary stated on behalf of Sandra Herrera, convenor for the revision of Guide 41 on packaging, that she would like to repeat her invitation to NSBs to nominate experts to participate in the work.

99. On behalf of all members of COPOLCO Sadie Homer thanked Anne Ferguson and Jeanne Bank for their dedicated work, wishing them all the best for their future endeavours.

COPOLCO Special Resolution 1/2015

COPOLCO

expresses its sincere thanks to Anne Ferguson (BSI – UK) and Jeanne Bank (SCC – Canada) for their dedicated work, leadership and longstanding commitment and contributions to COPOLCO, wishes them an excellent retirement.

Secretary's note: on behalf of COPOLCO, the Chair and Secretary also expressed their thanks to Robyn Easton after the COPOLCO meeting for leading the product safety working group and for her contributions to COPOLCO. Robyn Easton stepped down from the co-convenorship of the working group due to reorganization at Standards Australia.

Concluding remarks

100. The Chair thanked everyone who helped to make the COPOLCO plenary meeting and related events a success. She also thanked speakers and facilitators, for their support of the workshop, and COPOLCO members for their active participation. The next plenary will probably be in Geneva again.

101. Celine Awuor (KEBS) thanked ISO Academy and COPOLCO on behalf of the sponsored delegates from developing countries for the opportunity to participate in the training and the COPOLCO plenary and related events.

COPOLCO Special Resolution 2/2015

COPOLCO

expresses its deep appreciation to the Swiss Association for Standardization (SNV), sponsors, and the staff of the ISO Central Secretariat for their co-hosting and excellent support to the 2015 COPOLCO meeting and related events.



International Organization for Standardization
Organisation internationale de normalisation
Международная организация по стандартизации

**AGENDA ITEM 5 CHAIR'S AND SECRETARY'S REPORTS ON ITEMS
NOT OTHERWISE COVERED IN AGENDA**



AGENDA ITEM 5 REPORT OF THE CHAIR AND SECRETARY

COPOLCO ACTION COPOLCO is invited to comment on/approve the report.

1 ISO/COPOLCO Chair’s activity

At their March 2016 meeting, Council members expressed the importance of wider consumers’ engagement strategy and newer approaches to considering consumers in the age of the internet. There were also comments on promoting consumers’ involvement in standardization at national level which needed improvement. Several Council members urged that regional forums be used to improve consumer participation in standardization and focus on sub-regional standards forums as well.

The COPOLCO Chair urged the application and reference to the UN Guidelines on Consumer Protection, as there were significant references to the use of standards to improve consumer protection. The Chair also pointed out that the needs of developing country and developed country consumers differ. Developing country consumer participation in standardization is hampered by human resources capacity and funding.

Council members highlighted consumer challenges in online conformity assessment initiatives and benefits of using IT for effective market surveillance online or otherwise.

ISO Strategy 2016-2020; seven strategy programmes outlined and corresponding objectives and timeline were approved:

Strategic Program	ISO/CS Leadership	ISO Governance
Standards development	STAND	TMB
Stakeholder engagement	SG	TMB
Development and training	Academy	DEVCO
Marketing and communication	MCI (Marketing and Communication)	AD HOC GROUPS
Information technology services	ITS	AD HOC GROUPS, CSC/FIN
Conformity assessment	CAS/COP	CASCO, COPOLCO
IPR Protection	SG/Legal	AD HOC GROUPS, CSC/FIN

Relevant and manageable indicators associated to the Strategic Plan (SP)’s objectives are under development.

Other Updates on the Council Meeting:

1. Selection of ISO's Secretary General
2. Review of the nomination process of Policy and Development Committee (PDC) Chairs (current ISO COPOLCO Chair's term ends December 2017; new process to apply for chairs' selection)¹
3. ISO General Assembly (GA) week – 11-16 September, 2016; Beijing, China
4. Cooperation agreement with the South Asian Regional Standards Organization (SARSO) – information exchange between SARSO and ISO includes:
 - ISO's Strategic Plan and ISO Action Plan for developing Countries (APDC) and their yearly implementation plans, as well as other general policy documents;
 - ISO's technical work programme indicating progress and target dates;
 - Proposals for new fields of technical activity;
 - Working documents and meeting reports prepared for CASCO, COPOLCO, DEVCO and REMCO meetings.
5. Regional Engagement Initiatives (REI)
 - ISO Council approved, in March 2013, a two-year pilot to have an ISO Regional office based in Singapore (Singapore's REI).
 - Council Resolution 21/2015 continues with the initiative for a period of three years (reviewed annually).

Specific objectives of Singapore's REI are:

Promoting communication, collaboration and partnerships;

- i. strengthening the capacity of ISO members to understand the needs of their stakeholders and customers
- ii. supporting dissemination and effective use of information and communication materials developed by ISO for members in the region
- iii. facilitating cooperation among ISO members in the region; sharing experiences and good practices concerning stakeholder engagement (participation in standards development as well as use of standards).

Advocacy

- iv. helping members in the region with advocacy on standardization
- v. coordinating with the regional standardization organizations such as PASC and ASEAN, APEC (PASC).

Supporting training and technical assistance

- vi. supporting the efforts of ISO members in the region and of ISO/CS related to the implementation of the ISO Action Plan for Developing Countries 2016-2020.

Singapore's REI structure will comprise a Regional Director (Kevin Morrel) and a Project Manager (Kolin Low).

¹ ISO COPOLCO should also review or clarify its nomination and selection process for Working Group Convenors to support current work on succession planning.

ISO CASCO CPC, STAR, Plenary and Forum – May 1-6, 2016; Dubai, United Arab Emirates

ISO/CASCO's 6 May forum focused on stakeholder engagement. Panelists from different stakeholder groups, regions, and economic development backgrounds were invited to share best practices and concerns.

One expected outcome is for members to have better knowledge and understanding of the ISO/CASCO toolbox.

A verbal report on the outcome of the ISO/CASCO events will be provided at the June 2016 ISO/COPOLCO Plenary.

Other matters

Chair's proposal submitted to the APEC Sub-Committee on Standards and Conformance, for capacity building in online dispute resolution using ISO standards such as the ISO 10008 and 10003 among others.

Status will be updated at the June 2016 ISO/COPOLCO Plenary.

2 ISO/COPOLCO Secretary's activity

2.1 Meeting follow-up

COPOLCO's Secretariat followed up on the 2015 COPOLCO meeting: correspondence, surveys, circulating the minutes and workshop proceedings, and implementing the resolutions taken (Annex 1). The Secretariat also organized the COPOLCO Chair's Group and related meetings in November 2015.

The team is currently composed of Dana Kissinger-Matray, Katia Kerswell (60%) and Madeleine Emorine (50%).

2.2 Work programme and strategic issues

The Chair and Secretary worked with the COPOLCO Chair's Group to develop a COPOLCO work programme according to a modified template for use by all committees reporting to the ISO Council. The ISO Council approved it by correspondence (Council 38/2015) and ISO/COPOLCO was advised accordingly in February 2016 (N192/2016). Please find the approved work programme at Annex 2.

The Chair and Secretary also worked with the Chair's Group to develop a COPOLCO Strategy underpinning the newly developed ISO Strategy. A small task group developed a first draft after the Chair's Group meeting which was circulated to the wider Chair's Group membership. See Agenda item 7 for more details.

2.3 Communications

COPOLCO's mandate puts it in a special position to help ISO's consumer and public interest stakeholders and wider audiences appreciate the value of standardization.

Outreach to a broader base of consumers to generate interest in the benefit of standards for consumers is part of COPOLCO's communications strategy; it also reflects one ISO's stated directions summarized under "Communication" within the [ISO Strategy 2016-2020](#), which mentions both the ISO community and the general public.

The Secretary has been coordinating with the ISO Focus editor, Elisabeth Gasiorowski, to keep consumer views in the spotlight within the editorial planning for the ISO Focus magazine. A number of COPOLCO experts have been invited to contribute. The [back issues](#) are easily downloadable from iso.org. The themes of the next issues are:

May-June – Services

July-August – Trust

September-October – Internet of Things

November-December – Occupational Health and Safety (*to be confirmed*)

Furthermore, some communications professionals from the ISO Central Secretariat will cover the coming ISO Workshop, *Global services: ISO standards as solutions* and be conducting interviews of participants for ISO's social media.

COPOLCO's dedicated Web page, "ISOConsumers" (see facebook.com/ISOConsumers) has over 2'300 followers and its Twitter account (twitter.com/ISOConsumers) approximately 2'050 followers. COPOLCO's electronic newsletter, *ISO Consumer update* has a direct English-language readership of nearly 2'000. A French-language version is distributed to AFNOR and its network, and to the Réseau Normalisation et Francophonie (RNF).

2.4 New orientations

2015 was marked by a number of changes in policy directions and managerial structure at the ISO Central Secretariat. The COPOLCO Secretary, who was elected a member of the Staff Delegation in February 2015, was actively engaged in facilitating this transition.

While this period was challenging, consumer policy and COPOLCO will still be very relevant and will benefit in the long term. The new management team, led by Acting Secretary-General Kevin McKinley, is focusing more on the importance of stakeholder participation, addressing concerns of developing countries, and listening carefully to the needs expressed by the ISO members.

2.5 New reporting line

The consumer policy and the conformity assessment units have been merged to take advantage of synergies of working in policy issues. Dana Kissinger-Matray now reports to Sean MacCurtain, Head of Conformity Assessment. CASCO and COPOLCO have cooperated on a number of projects in the past, and their chairs often attend each other's meetings. Common areas of interest include – but are not limited to – standardization of services, integrity of the supply chain, confidence in certification, as well as sustainability and other kinds of labelling.

2.6 Representation activity

The COPOLCO Secretary responds to requests for orientation about COPOLCO on-site. At AFNOR's invitation; in June 2015, she spoke at a national awareness-raising event for French technical experts and stakeholders about ISO and ISO/IEC Guides.

The COPOLCO Secretary is also part of a team receiving delegations from ISO members and liaison organizations who come to the ISO Central Secretariat to learn more about ISO's work. She uses this opportunity to explain COPOLCO's role and contributions to the ISO System. On 24 June, she will participate in an orientation for

ISO member representatives from countries that have recently upgraded their membership in ISO.

2.7 Training events

Since May, the COPOLCO Secretariat has cooperated with the ISO Academy team to organize two more events in addition to the training workshop held in Geneva on 11 May. The first, a half-day conference on consumer participation in standardization, was held in Addis Ababa, Ethiopia, as an additional part of the African Regional Standards Organization (ARSO) General Assembly. This was the culmination of contacts undertaken in 2012 by Norma McCormick, past COPOLCO Chair, and further discussions between ARSO officers and the current Chair and Secretary. It was notable for two reasons: a large forum was given to consumer policy within a regional organization's annual meeting, which provided an excellent opportunity to reach an entire region with a single event. The Secretary feels this kind of involvement in meetings of regional organizations is potentially impactful and more time- and cost-effective than visiting individual members or smaller groups.

In October and November 2015, the COPOLCO Secretariat and ISO Academy organized several side events at Consumers International's World Congress on 18 November. One was an interactive training modeled on the one held in Geneva in May. The other awareness-raising workshop featured ISO's Acting Secretary-General on a panel to explain on the benefits of standards for consumers. He also took part in a panel in the Congress plenary on 20 November debating the role of standards in legislation.

More details appear under Agenda item 14.

2.8 ISO/IEC Guides

The Secretary has also continued with the revision of ISO/IEC Guides 14, 46, and 76 this year (see Agenda items 10 and 15).

2.9 Membership of COPOLCO

COPOLCO currently has 124 members, of which 73 are P-Members and 51 are O-Members. We welcome a new member: DGNTI (Panama) joining as a P-Member. MSM (Mongolia), INEN (Ecuador), BSTI (Bangladesh) and NSI (Namibia) have also upgraded their memberships to "P".

Draft resolutions:

COPOLCO Resolution x/2016

COPOLCO

approves the Chair's and Secretary's report (COPOLCO N207).

Annexes:

Annex 1 – Follow-up to the resolutions

Annex 2 – 2016 COPOLCO Work Programme

Annex 3 – COPOLCO member list

Annex 4 – Terms of reference of COPOLCO's standing groups



38TH MEETING OF ISO/COPOLCO – RESOLUTIONS

Follow-up to the resolutions

COPOLCO Resolution 1/2015

ISO Strategy consultation

COPOLCO

notes the development of the *ISO Strategy 2016-2020*, and its planned completion in September 2015,

approves the development of a corresponding COPOLCO strategy to support the aims and priorities of the *ISO Strategy 2016-2020*, as appearing in COPOLCO 10/2015,

notes comments made during the meeting about consumer participation in standards work at the national and international levels,

requests the COPOLCO Chair's Group and the Consumer participation and training working group to:

- consider how to apply COPOLCO's Terms of Reference to support consumers' interests in standards;
- develop further guidance to help consumer representatives be effective in representing consumers' interests in their relevant areas;
- propose a programme at the ISO General Assembly to promote the advantages of consumer representatives' participation, based on the principle of balanced stakeholder participation, to CEOs of National Standards Bodies attending the GA; and,
- work with the ISO Central Secretariat to consider the feasibility of approaching donor agencies to fund participation of consumer representatives in targeted technical areas.

Several actions have been taken: the Chair's Group has developed a draft of the COPOLCO implementation of the 2016-2020 ISO Strategies. The COPOLCO Chair has launched a number of international and regional initiatives to promote the consumer including at the General Assembly (see COPOLCO N207). The Consumer participation and training group's funding task group will report on its initiatives during the plenary meeting.

COPOLCO Resolution 2/2015

COPOLCO's visibility and impact to members

COPOLCO

notes the report of the COPOLCO Chair appearing at COPOLCO 11/2015,

approves the recommendations proposed, with addition of comments made at the meeting.

The COPOLCO Chair and Secretary have refined the questionnaire in light of comments and the final version will be launched shortly. The COPOLCO Chair has developed a preliminary action plan and timetable appearing at Agenda item 6 (COPOLCO N208).

COPOLCO Resolution 3/2015

Consumer issues in standardization of services (1)

COPOLCO

approves the proposed Terms of Reference of ISO/COPOLCO working group 18, *Consumers' issues in standardization of services*, appearing in COPOLCO 13/2015.

No further action needed.

COPOLCO Resolution 4/2015

Consumer issues in standardization of services (2)

COPOLCO

notes the results of the systematic review and report appearing at Annexes 3 and 4 to COPOLCO 13/2015,

further notes comments made at the meeting,

decides to revise ISO/IEC Guide 76, *Development of service standards – Recommendations for addressing consumer issues*,

invites COPOLCO WG 18 to start revision of the Guide.

ISO/IEC WG 18 started work by correspondence in 2015 and developed an outline of the future working draft at its meeting on 1-2 March 2016. More details appear under Agenda item 10.

COPOLCO Resolution 5/2015

Key areas for consumers (1)

COPOLCO

thanks Takashi Nakakuki for his willingness to take the responsibility as co-Chair of COPOLCO WG 2 Key areas for consumers,

appoints Mr Nakakuki as co-Chair of this working group.

No further action needed.

COPOLCO Resolution 6/2015

Key areas for consumers (2)

COPOLCO

approves unit pricing as a new key area, supporting the newly-established ISO/PC 294, *Guidance on unit pricing*.

The Key areas for consumers working group has confirmed John Furbank as the Key Person in this area. More details appear under Agenda item 11.

COPOLCO Resolution 7/2015

Key areas for consumers (3)

COPOLCO

thanks the Key areas for consumers working group for its report and annexes appearing at COPOLCO 15/2015,

approves the report "Standards for consumers – Update", project overview, template for new submissions and list of consumer standards published as annexes to COPOLCO 15/2015.

No further action needed.

COPOLCO Resolution 8/2015

2015 workshop, The connected consumer in 2020 – empowerment through standards

COPOLCO

thanks the speakers, facilitators and rapporteurs for their contributions to the 2015 workshop, *The connected consumer in 2020 – empowerment through standards*,

emphasizes the need to adapt business and standardization methods to meet the challenges posed by the rise of the collaborative economy and innovative business models,

decides to request the Consumer protection in the global marketplace working group to undertake a gap analysis of existing standards within ISO, IEC and ISO/IEC JTC1, the ITU and UN/ECE on privacy and protection of personal data to identify areas needing further work in consumer protection, for the consideration of the COPOLCO Chair's Group at its next meeting in November 2015,

notes strong support for the gap analysis expressed by representatives from Kenya and other developing countries to ensure that developing country privacy concerns are factored into the analysis,

further notes that comments made at the workshop and plenary meeting about privacy will be considered for the gap analysis,

invites IEC representatives to participate regularly in COPOLCO's plenary and Chair's Group meetings,

emphasizes the need for ISO to coordinate appropriately with IEC and ITU on privacy and personal data protection issues, recognizing the need for consumers' dynamic, real-time and active control over use of their personal data.

A gap analysis report and new activity template on the collaborative economy have already been developed, and actions on privacy by design will be proposed at the meeting. Liaison has taken place with IEC on wearable computing. See Agenda item for more details.

COPOLCO Resolution 9/2015

Consumer participation and training working group (1)

COPOLCO

thanks the Consumer participation and training working group for its report at COPOLCO 16/2015,

approves its continued activities as outlined in the work plan,

welcomes efforts to re-introduce regional training, particularly for those from developing countries; and,

thanks the ISO Academy, trainers, and participants for the successful training session on 11 May 2015.

The Consumer participation and training group organized two additional training events in 2015. See Agenda item 14 for more details.

COPOLCO Resolution 10/2015

Consumer participation and training working group (2)

COPOLCO

notes plans to revise the *ISO Directory of consumer participation* to disseminate information about activities of the Consumer participation and training group work plan, such as the funding database.

See Agenda item 14.

COPOLCO Resolution 11/2015

Consumer participation and training working group (3)

COPOLCO

thanks Caroline Warne for her work in developing new guidance on COPOLCO mirror committees and COPOLCO contact persons,

requests COPOLCO members to encourage consumer participation at the national level,

further requests the consumer participation and training working group to revise the document in light of comments made at the meeting, and recirculate it to the members of COPOLCO,

recommends that, on completion, this guidance be disseminated widely among the COPOLCO membership and included in relevant training sessions.

The comments were considered and the final version of the guidance was circulated to the members of COPOLCO in August 2015 (COPOLCO 29/2016 – COPOLCO N171)

COPOLCO Resolution 12/2015

Consumer participation and training working group (4)

COPOLCO

thanks the outgoing co-Chair Anne Ferguson (BSI – UK) for her work,

approves the appointment of Sadie Homer (CI) as the new co-Chair of the working group.

No further action needed.

COPOLCO Resolution 13/2015

Product safety working group (1)

COPOLCO

approves the report of the Product safety working group (PS WG) at COPOLCO 17/2015,

notes the continued input from the PS WG into the revision and promotion of ISO/IEC Guides,

further notes the revisions in 2014 of:

- ISO/IEC Guide 50, *Safety aspects – Guidelines for child safety in standards and other specifications*
- ISO/IEC Guide 51, *Safety aspects – Guidelines for their inclusion in standards; and,*
- ISO/IEC Guide 71, *Guide for addressing accessibility in standards;*

thanks the Product safety working group members for their contributions in these areas.

No further action needed.

COPOLCO Resolution 14/2015

Product safety working group (2)

COPOLCO

notes the submission of the new work item proposals, ISO/IEC 82079-2, *Preparation of instructions – Structuring, content and presentation – Part 2 – Provisions for instructions for self-assembly products;* and *Choking hazards of small component parts* to ISO TC 10 for ballot,

further notes positive comments, but non-acceptance of these proposals due to an insufficient nomination of experts, and the decision of ISO/TC 10 to forward NWIP ISO/IEC 82079-2 to IEC/TC 3 for further consideration and ballot closing on 7 August 2015.

decides to resubmit the NWIP, *Choking hazards of small component parts* for consideration by another technical committee, such as ISO/TC 122, *Packaging*.

The NWIP, Choking hazards of small component parts, failed to progress because TC 122 considered the subject area out of the scope of the Technical Committee.

IEC/TC 3 has taken over the work on ISO/IEC 82079-2 on instructions for self-assembly products; as an approved work item under the reference 3-1222.

COPOLCO Resolution 15/2015

Product safety working group (3)

COPOLCO

thanks the Product safety working group for their scoping document on *Quantification of risk assessments*, appearing at Annex 1 to COPOLCO 17/2015,

notes comments made, and the proposal to appoint a task group to redraft it,

invites the Product safety working group to resubmit the draft for further consideration of members,

recognizes the importance of other safety issues presented in COPOLCO 17/2015,

further invites the group to submit a progress report for members' consideration at the 2016 COPOLCO meeting.

See Agenda item 13.

COPOLCO Resolution 16/2015

Product safety working group (4)

COPOLCO

thanks ANEC for its report on issues relating to safety of products appearing at COPOLCO 25/2015,

strongly supports ANEC's campaign to delete the exclusion clause from the parent IEC 60335 standards, and other standards for consumer products,

further supports lowering of surface temperature limits in the IEC 60335 series of standards,

invites members with the national representation in IEC/TC 108 to support ANEC on safety issues relating to audio-video equipment.

No further action needed.

COPOLCO Resolution 17/2015

Global marketplace working group (1)

COPOLCO

thanks the Global marketplace working group for its report at COPOLCO 18/2015,

approves the activity template on business-to-consumer communication appearing at Annex 1 to COPOLCO 18/2015,

notes the ongoing revision of ISO/IEC Guide 14, *Purchase information on goods and services intended for consumers*,

supports future conversion of ISO/IEC Guide 14 into an International Standard, upon its publication.

A preliminary report has been prepared for the advance information of the ISO Technical Management Board.

Further actions will be taken on completion of the Committee Draft Ballot for ISO/IEC Guide 14.

See Agenda item 15 for further details.

COPOLCO Resolution 18/2015

Global marketplace working group (2)

COPOLCO

notes the work of the British Standards Institution on consumer vulnerability as described in COPOLCO 18/2015,

invites its members to contact the COPOLCO Secretariat to indicate their interest in participating in any future work in this area,

requests the Secretary to correspond with members to gather views and information about the interest and relevance of international work on consumer vulnerability.

The COPOLCO Secretary launched Committee Internal Ballots on this issue (N197) and on financial literacy for youth (N196). The results have been compiled and appear as part of Agenda item 12.

COPOLCO Resolution 19/2015

Global marketplace working group (3)

COPOLCO

notes the release of ISO 12812, *Core Banking – Mobile Financial Services* (all parts) as a Draft International Standard,

encourages its members to provide support to comments and votes on the ballot.

No further action required. See Agenda item 12 for more details.

COPOLCO Special Resolution 1/2015

COPOLCO

expresses its sincere thanks to Anne Ferguson (BSI – UK) and Jeanne Bank (SCC – Canada) for their dedicated work, leadership and longstanding commitment and contributions to COPOLCO,

wishes them an excellent retirement.

No further action required.

COPOLCO Special Resolution 2/2015

COPOLCO

expresses its deep appreciation to the Swiss Association for Standardization (SNV), sponsors, and the staff of the ISO Central Secretariat for their co-hosting and excellent support to the 2015 COPOLCO meeting and related events.

No further action required.

2016 COPOLCO work programme
(as approved under Council Resolution 38/2015)

	Actions	Expected result	Responsible	Target	Status
1	<p>Develop an underlying COPOLCO strategy to underpin the aims and priorities of the ISO Strategy 2016-2020:</p> <ul style="list-style-type: none"> • Write and approve a “COPOLCO Action Plan for consumer interests”. 	Align COPOLCO’s activities and priorities with those of ISO.	Chair and Chair’s Group	<ul style="list-style-type: none"> • Approve the draft at the COPOLCO meeting in June 2016. 	
2	<p>Increase the visibility and impact of consumer interests’ role in ISO, especially among developing countries:</p> <ul style="list-style-type: none"> • Assess the impact of training and awareness raising events in: <ul style="list-style-type: none"> - Geneva (COPOLCO plenary), - Addis Ababa (ARSO GA), and - Brasilia (CI World Congress). • Hold a training and awareness-raising event in Vienna for CIS and Central Asian countries 	Increase capacity of members and make the role of consumer interests in the ISO system at the policy and technical levels more fully understood.	<p>Chair and Secretary with COPOLCO WG 03, “Consumer participation and training”</p> <p><i>Supported by the ISO Academy</i></p> <p>COPOLCO Chair</p>	<ul style="list-style-type: none"> • June 2016 • September 2016 	
3	<p>Contribute to ISO’s technical and policy work on services standardization:</p> <ul style="list-style-type: none"> • Develop a Committee Draft of ISO/IEC Guide 76. • Write a research paper on services standardization from the consumer’s 	<p>Make good guidance available to technical committees and policy groups on services standardization from the end-user’s perspective.</p> <p>Support ISO’s effort to</p>	COPOLCO WG 18 “Consumer issues in service standardization”	<ul style="list-style-type: none"> • June 2016 	

	Actions	Expected result	Responsible	Target	Status
	point of view, based on survey findings and collection of case studies.	develop a coherent market-relevant strategy in services standardization by providing input from the consumer's point of view. Contribute to adapting policy on services standardization in ISO better to respond to stakeholders' needs.			
4	Address consumer protection issues for product information, privacy and protection of personal data: <ul style="list-style-type: none"> • Undertake a gap analysis of existing standards of ISO, IEC and ISO/IEC JTC 1 and the ITU and UN/ECE to identify areas needing further work. • Develop positions and possible future work items on other high-priority areas identified at the plenary meeting, depending on gap analysis findings: privacy by design, wearable computing, and standards for the collaborative economy. 	Market-relevant proposals for policy and deliverables on privacy and personal data, to be considered by ISO in collaboration with its partners.	COPOLCO WG 05 "Consumer protection in the global marketplace"	<ul style="list-style-type: none"> • June 2016 • NWIPs on high-priority areas: December 2016 	
5	<ul style="list-style-type: none"> • Complete and submit a justification study on business-to-consumer communication • Propose the revision of ISO/IEC Guide 14, <i>Purchase information on goods and services intended for consumers</i> into an International Standard 	If approved for development in a TC or PC, enhance consumer protection and information through development of standards tools for use by suppliers.	COPOLCO WG 05, "Consumer protection in the global marketplace"	<ul style="list-style-type: none"> • February 2016 • February 2016 	

	Actions	Expected result	Responsible	Target	Status
6	Publish the revision of ISO/IEC Guide 46, <i>Comparative testing of consumer products and related services – General principles</i> .	Improved understanding by technical committee experts, specialists and consumer organizations of comparative testing and its relevance to consumers.	COPOLCO WG 12, "Revision of ISO/IEC Guide 46"	<ul style="list-style-type: none"> June 2016 	
7	<p>Improve profile, networking and coordination among consumer representatives in the ISO System.</p> <ul style="list-style-type: none"> Publication of <i>Standards and consumers – Update 2016</i> Re-design and update <i>the ISO Directory of consumer interest participation</i>, taking account of new key areas for consumer participation and evolving information needs. 	Reliable and easily visible indicators of representation by the consumer stakeholder group in ISO's policy and development work.	<p>COPOLCO WG 02, "Key areas group"</p> <p>COPOLCO WG 03, "Consumer participation and training"</p> <p>Supported by the COPOLCO Secretariat</p>	<ul style="list-style-type: none"> June 2016 December 2016 	
8	Circulate the Committee Draft of ISO/IEC Guide 41, <i>Packaging – Recommendations for addressing consumer needs</i> to the members of ISO and IEC.	Align consumers' needs with state of the art in safety, sustainability and product information aspects of packaging	COPOLCO WG 16 "Revision of ISO/IEC Guide 41"	<ul style="list-style-type: none"> December 2016 	
9	<p>Conduct outreach to the broader community about the benefits of ISO standards:</p> <ul style="list-style-type: none"> Publish quarterly Newsletter, ISO Consumer update Maintain and feed <i>ISOConsumers</i> Facebook and Twitter accounts. 	Raise ISO's profile and publicize market relevance of standards as aids to consumer protection	COPOLCO Secretariat	<ul style="list-style-type: none"> Newsletter: 4x a year Social media: several times a week 	

	Actions	Expected result	Responsible	Target	Status
10	Organize a workshop to explore a theme of consumer interest to assess relevance for standards work (annual event).	Discern market trends and market demand for potential new standardization areas	COPOLCO WG 01 "Chair's Group"	<ul style="list-style-type: none"> • June 2016 	
11	Study the feasibility of proposing a guidance standard on general principles on risk management for safety of consumer products.	If approved, development of a tool to help manufacturers improve product safety (pending approval and addition to the work programme of a technical committee or project committee)	COPOLCO WG 04 "Product safety"	<ul style="list-style-type: none"> • June 2016 	
12	Study the feasibility of initiatives to protect vulnerable populations: <ul style="list-style-type: none"> • Consult COPOLCO members on demand for a deliverable on the "vulnerable consumer" • Review proposal on financial information for youth • Social media-based awareness raising against counterfeiting 	If approved, development of widely applicable guidance for use by authorities, manufacturers and standards-writers.	COPOLCO WG 05 "Consumer protection in the global marketplace"	<ul style="list-style-type: none"> • June 2016 	



Members of COPOLCO – 38th meeting

P-members

Algeria	IANOR
Argentina	IRAM
Australia	SA
Austria	ASI
Bahrain	BSMD
Bangladesh	BSTI
Barbados	BNSI
Botswana	BOBS
Brazil	ABNT
Bulgaria	BDS
Canada	SCC
Chile	INN
China	SAC
Colombia	ICONTEC
Costa Rica	INTECO
Cyprus	CYS
Czech Republic	UNMZ
Denmark	DS
Ecuador	INEN
Egypt	EOS
Fiji	DNTMS
Finland	SFS
France	AFNOR
Germany	DIN
Ghana	GSA
India	BIS
Indonesia	BSN
Iran, Islamic Republic of	ISIRI
Ireland	NSAI
Israel	SII
Italy	UNI

Jamaica	BSJ
Japan	JISC
Kazakhstan	KAZMEMST
Kenya	KEBS
Korea, Republic of	KATS
Libya	LNCSM
Malawi	MBS
Malaysia	DSM
Malta	MCCAA
Mauritius	MSB
Mexico	DGN
Namibia	NSI
Netherlands	NEN
Nigeria	SON
Norway	SN
Oman	DGSM
Pakistan	PSQCA
Panama	COPANIT
Peru	INDECOPI
Portugal	IPQ
Romania	ASRO
Russian Federation	GOST R
Saudi Arabia	SASO
Serbia	ISS
Singapore	SPRING SG
Slovenia	SIST
South Africa	SABS
Spain	AENOR
Sri Lanka	SLSI
Sudan	SSMO
Sweden	SIS
Switzerland	SNV
Thailand	TISI
Trinidad and Tobago	TTBS
Tunisia	INNORPI
Turkey	TSE

United Arab Emirates	ESMA
United Kingdom	BSI
United States	ANSI
Uruguay	UNIT
Zimbabwe	SAZ

O-Members

Albania	DPS
Armenia	SARM
Azerbaijan	AZSTAND
Belarus	BELST
Belgium	NBN
Bolivia	IBNORCA
Bosnia & Herzegovina	BAS
Brunei Darussalam	ABCI
Burundi	BBN
Cameroon	ANOR
Croatia	HZN
Cuba	NC
Dominica	DBOS
Dominican Republic	INDOCAL
El Salvador	OSN
Ethiopia	ESA
Gabon	ANTT
Gambia	TGSB
Greece	NQIS ELOT
Hungary	MSZT
Iceland	IST
Iraq	COSQC
Jordan	JSMO
Latvia	LVS
Lebanon	LIBNOR
Lithuania	LST
Luxembourg	ILNAS
Macao	CPTTM

Mali	AMANORM
Moldova, Republic of	INSM
Mongolia	MASM
Montenegro	ISME
Morocco	IMANOR
Mozambique	INNOQ
Myanmar	MSTRD
Namibia	NSI
Nepal	NBSM
New Zealand	SNZ
Palestine	PSI
Philippines	BPS
Poland	PKN
Qatar	QS
Saint Lucia	SLBS
Senegal	ASN
Seychelles	SBS
Sierra Leone	SLBS
Slovakia	SUTN
Swaziland	SWASA
Tanzania, United Rep. of	TBS
Uganda	UNBS
Ukraine	DTR
Viet Nam	STAMEQ
Zambia	ZABS

TERMS OF REFERENCE: ISO/COPOLCO STANDING GROUPS

Chair's group

Purpose:

The purpose of the Chair's Group is to assist the Chair in advancing the work of ISO/COPOLCO and fulfilling COPOLCO's mandate.

Roles and responsibilities include:

- Planning the next COPOLCO workshop and plenary in collaboration with the host country;
- Reviewing progress reports from COPOLCO working groups, discussing the content and quality of their work programmes, verifying that expected actions are being taken, and helping resolve issues that may arise;
- Monitoring the implementation of the resolutions from the previous plenary meeting; discussing required actions, tracking progress, and providing direction to establish priorities;
- Providing advice and counsel to the Chair on specific matters and making recommendations for resolution or action;
- Reviewing requests for liaison from organizations and evaluating these against established criteria to determine suitability for acceptance;
- Encouraging and facilitating the active participation of all members of COPOLCO working groups.

Members:

- Current and past chairs of COPOLCO, and the COPOLCO secretariat;
- Convenors of COPOLCO working groups;
- Designated representatives of COPOLCO P-members who wish to contribute to the Chair's Group and who contribute actively to COPOLCO, with particular emphasis on members from developing countries;
- Representatives of organizations with which COPOLCO has formal liaison or a close working relationship.

Invited by the Chair:

- COPOLCO member hosting the next year's COPOLCO meeting and workshop;
- COPOLCO member who hosted the immediate past meeting and workshop;
- Person(s) invited by the Chair to provide expertise pertaining to specific subjects/issues on the agenda;
- Attendees to the working group meetings held in conjunction with the Chair's Group who are not already participating in the Chair's Group meeting.

Corresponding:

COPOLCO members wishing to be kept informed of the Chair's Group activity by correspondence or by teleconference.

Meetings:

A Chair's Group meeting will be held approximately six months after the annual plenary.

Review:

These Terms of Reference shall be reviewed on a regular basis.

COPOLCO WG 02 “Key areas for consumers”

The Working Group on Key areas for consumers operates as a standing committee under the authority of ISO/COPOLCO. It supports the ISO COPOLCO Chair and Secretary by providing information on key areas of work in standardization relevant to consumers, working towards continuous improvement in the delivery of this mandate, while taking account of the needs of developing countries and emerging economies.

Mandate:

- To identify and monitor key areas of standards work in ISO and IEC of interest to consumers including emerging areas, horizontal issues, and mature technical committee work;
- To raise awareness of these areas and disseminate information to the ISO membership, the ISO/COPOLCO members, consumer organizations and consumer representatives, standards development organizations, and members of technical committees and subcommittees;
- To facilitate networking amongst individuals interested in areas of consumer interest.

COPOLCO WG 03 “Consumer participation and training”

The Consumer participation and training working group is a standing committee under the authority of ISO/COPOLCO, in support of the COPOLCO work programme and relevant parts of the ISO Strategic Plan. Its objectives are to increase and promote effective consumer involvement in standardization relevant to consumers, taking account of the needs of developing countries and emerging economies.

Mandate:

- To promote awareness of standardization amongst consumers and consumer organizations;
- To promote an understanding of consumer issues and the value of consumer participation in standardization amongst standards bodies and other standards stakeholders;
- To explore and address barriers to consumer participation in standards policy, technical work and the processes involved, and encourage active participation;
- To encourage and develop training and supporting materials to facilitate the achievement of the preceding activities.

COPOLCO WG 04 “Product safety”

The Product safety working group operates as a standing committee under the authority of ISO/COPOLCO. The group investigates how adequately the issue of safety is being addressed within ISO's system of standardization.

The PS WG supports ISO/COPOLCO's Chair and Secretary by providing information on the safety of products for consumers and by highlighting current and future areas of concern, particularly for developing countries and emerging economies.

Mandate:

- to promote the design, manufacture, assembly, sale and disposal of safer consumer products via COPOLCO and ISO;
- to develop greater consistency and coherence in requirements for safety in standards;
- to encourage networking and communication between COPOLCO and ISO members on issues of safety to respond to calls for information and advice on product safety issues.

COPOLCO WG 05 “Consumer protection in the global marketplace”

To develop proposals in the consumer interest for both online and conventional transactions in the global marketplace.

COPOLCO WG 18 “Consumer issues in services standardization”

- To promote awareness and understanding of services standardization among consumers and consumer organizations;
- To promote understanding of important consumer issues in services standardization within ISO, among standards bodies and other standards stakeholders;
- To identify consumer issues and needs in standardization in services;
- To explore and address issues of consumer participation in standardization of services.

NOMINATION PROCESS FOR CHAIRS OF POLICY DEVELOPMENT COMMITTEES (PDC)

Process to appoint Chairs of the ISO Policy Development Committees:

- 1) ISO has three policy development committees (PDC): DEVCO (Committee on developing country matters) , CASCO (Committee on Conformity Assessment) and COPOLCO (Committee on Consumer Policy).
- 2) Council appoints a Chair for each PDC for a period of two years (renewable once).
- 3) Each PDC has a detailed profile and job description for the Chair, approved by Council. See [here](#) for the each profile and job description.
- 4) Process for nomination of a PDC Chair:
 - a. 12 months prior to the effective date of appointment, the PDC Secretariat shall send out a call for nominations for Chair to all ISO members who are members of the specific PDC.
 - b. The call for nominations shall be accompanied by the job description and profile. 4 weeks shall be given to members of the PDCs to nominate one candidate.
 - c. All nominations shall be supported with a curriculum vitae of the nominee and any other useful document. (Nominating members are required to take note of the requirements regarding the profile of the PDC Chair and the characteristics of the NSB supporting the Chair's nomination).
 - d. The President committee and the relevant outgoing PDC Chair shall review and consider the nominations. The names of all candidates, meeting the criteria, will be communicated to Council along with one recommended nominee for the position.
 - e. The ISO Council shall appoint the PDC Chair. Unsuccessful candidates shall be informed of the outcome of their nomination.
 - f. The PDC members shall be informed of the successful candidate.
- 5) Process for nomination for reappointment of a PDC Chair:
 - a. At least 12 months prior to the end of the first terms of office of the PDC the President Committee shall decide whether to invite the PDC Chair to extend their term of office for another 2 years.
 - b. Where an invitation has been extended and the Chair has accepted this shall be recommended to the Council.
 - c. Where the Presidents Committee has decided not to extend an invitation for extension or where the PDC Chair does not wish to extend the term, the PDC Secretariat shall implement this procedure as in 4) for a call for nominations.

JOB DESCRIPTION OF COPOLCO CHAIR

The COPOLCO Chair is appointed by Council for a two-year term renewable once.

Roles and responsibilities of the Chair:

1. Provides leadership to the ISO committee on consumer policy (COPOLCO) in accordance with its terms of reference
2. Supports the implementation and monitoring of the COPOLCO work programme
3. Chairs meetings of COPOLCO and the Chair's Group
4. Assures, as supported by the COPOLCO Secretary and staff, that the work of COPOLCO is carried out efficiently.
5. Promotes constructive debate and effective participation by all ISO members and partner organizations during COPOLCO meetings.
6. Encourages effective communication on technical issues between ISO and ISO members and key stakeholders of ISO; and represents COPOLCO in relevant bodies within CASCO.
7. Participates in ISO Council and its Standing Committees as a non-voting member of Council
8. Represents ISO at national, regional and international events as agreed with the Secretary-General.
9. Promotes the importance of International Standards and the role of ISO in the area of consumer policy
10. Liaises closely with the COPOLCO Secretary and Secretary-General

Profile of Chair:

1. Should be familiar with ISO Governance bodies, i.e. at least regular participation in ISO GA or meetings of COPOLCO. Possibly, having served on Council. However, during years of projected term of office as COPOLCO chair, the person may not be a member body representative on Council, the TMB or the other ISO policy development committees
2. Should have a strong and direct link as well as a close alignment with the ISO member in their country, ideally in a governance role
3. Should be familiar with broader consumer issues and trends.
4. Should have previously demonstrated chairing skills, such as consensus-building, assertiveness, impartiality and group dynamics management. Should also be a good

communicator in a multicultural environment to be properly and clearly understood by all participants during COPOLCO meetings. That is to speak slowly, to avoid acronyms, to use presentations to support speeches and discussion of COPOLCO papers, etc.

5. Should commit to the time required for the role

Characteristics of the NSB supporting the Chair

1. The NSB should have been in existence for at least 10 years and managed by a Board/Council with a strong commitment to consumer participation in standardization.
2. The NSB Board/Council undertakes to support the Chair to devote necessary time and funds for chairing COPOLCO and related meetings
3. The NSB's span of activities should encompass at least standardization, sales and promotion, and possibly training, consultancy or conformity assessment
4. The NSB is P-Member of COPOLCO and in a number of TCs/SCs to show they have a working knowledge of participating in ISO standards development.

NOTE – The estimated workload of the COPOLCO chair can be found on the following page.

COPOLCO CHAIRMANSHIP – ESTIMATED WORKLOAD

As of 1 March 2013, COPOLCO, the ISO consumer policy committee, comprises 111 members (65 P-members, i.e. participating members, and 46 O-members, i.e. observer members).

The COPOLCO Chair is appointed by the ISO Council for a two-year term and is eligible for a second term.

The position of COPOLCO Chair is quite a prominent one, since COPOLCO is one of ISO's three policy development committees (the other two being CASCO on conformity assessment and DEVCO on developing country matters). The workload devolving on the COPOLCO Chair is estimated on average at 16 to 20 days, including travelling, optional representation and administrative tasks. It can be split into two groups, one consisting of mandatory tasks and the other consisting of optional tasks to be carried out at the discretion of the Chair.

a) Mandatory tasks

- attending yearly COPOLCO meeting and workshop (venues arranged by invitation on the part of a member body. Following is a list of past venues: Canada in 2005, Malaysia in 2006, Brazil in 2007, Korea in 2008, India in 2009, Indonesia in 2010, United Kingdom in 2011, and Fiji in 2012. The 2013 meeting will take place in Malta in 2013.);
- attending COPOLCO Chair's advisory group (once a year, usually in November);
- attending all Council meetings (usually in Geneva in March and various other locations in September in conjunction with the General Assembly);
- participating, either in person or by correspondence, in the Council Strategy and Policy Committee meetings. These normally take place in January and June in Geneva.

b) Optional tasks

The attendance of the Chair at certain events may be desirable but is not mandatory. The Chair's participation is at the discretion of the Chair in consultation with the Secretariat. Examples include:

- COPOLCO/DEVCO training events in conjunction or not with the COPOLCO plenary;
- major ISO events of strategic importance, especially if invited as a speaker (example: TC/SC Chairs' Conference);
- plenary meetings of other PDCs (DEVCO and CASCO);
- Working groups of CASCO, such as CASCO CPC or STAR;
- regional ISO-related events, especially if invited as a speaker;
- ISO General Assembly as part of a national delegation;
- Occasional meetings of organizations in liaison with COPOLCO (OECD, Consumers International, OIML, IEC).



International Organization for Standardization
Organisation internationale de normalisation
Международная организация по стандартизации

NEW WORK ITEMS AND ISSUES – GENERAL MATTERS



International Organization for Standardization
Organisation internationale de normalisation
Международная организация по стандартизации

**AGENDA ITEM 6 RAISING THE PROFILE OF CONSUMER INTERESTS
IN THE ISO SYSTEM (AWARENESS AND CAPACITY
BUILDING)**



AGENDA ITEM 6 RAISING THE PROFILE OF CONSUMER INTERESTS IN THE ISO SYSTEM (AWARENESS AND CAPACITY BUILDING)

COPOLCO ACTION: COPOLCO is invited to note/comment on the report and approve the proposed resolution.

Background

At the 2015 plenary meeting, COPOLCO approved a series of actions and commented on a draft questionnaire (COPOLCO 11/2015). The aim, enhancing COPOLCO's visibility among ISO members and experts, was a result of discussions at the 2014 GA. At this event, some NSB CEOs did not see the value of ISO COPOLCO and its results trickling down to the national level.

The following action items are under way

- Send the revised questionnaire to NSBs and some TCs (see below)
- Set up an action plan to increase COPOLCO's visibility within ISO (Chair and Secretary)
- Generally, to increase communication to all stakeholders of the ISO community about the impact of COPOLCO's work (Chair and Secretary, COPOLCO CG, CP &T) (according to the ISO Strategy Implementation under Agenda Item 7)-

COPOLCO Resolution 2/2015

COPOLCO's visibility and impact to members

COPOLCO

notes the report of the COPOLCO Chair appearing at COPOLCO 11/2015,

approves the recommendations proposed in the report, with addition of comments made at the meeting.

The questionnaire has been revised overleaf to take into account comments from COPOLCO members made at the 2015 plenary, and at this writing was planned for release to the members of COPOLCO in May.

Questions revised in light of ISO/COPOLCO members' comments.

Members are highly encouraged to comment on the questions to ensure that the responses will indeed help develop an effective communication and visibility initiatives for ISO COPOLCO within the ISO System.

1. How long has your National Standards Body (NSB) been a COPOLCO member?
2. Why did your NSB become an ISO/COPOLCO member?
 - help national consumers benefit from standards
 - help promote importance of standards to national consumers
 - help promote importance of standards to consumer government agencies
 - help national consumers participate in national standards development
 - bring national consumer interests to international standards development
 - exchange of best practices between NSBs and consumer representatives
 - help identify global consumer issues in international standards development
 - help identify social (non-economic) benefits of standards
 - Help consumer interests join an international network
 - other _____
 - We don't have that information.
3. What benefits did you / NSB / country get from being ISO COPOLCO member?
 - share best practices in promoting consumer involvement in standards development
 - promote national consumer issues to ISO COPOLCO and ISO
 - others [please state.....]
4. What are your expectations from ISO/COPOLCO through ISO in light of the new ISO strategy?
 - training and information on consumers participation in standards development
 - matching financial resources to promote consumer involvement in COPOLCO and key areas of standards development (food safety, energy management, water efficiency, e-commerce etc.)
 - cater for individual NSB needs
 - ISO/COPOLCO and DEVCO/CASCO work communicate/exchange consumer issues
 - enhance consumers' role in promoting compliance / use of standards
 - promote more interaction between ISO/COPOLCO and Technical Committees relevant to consumer issues / Key areas
 - help make standards more market-relevant
 - other reasons (please state): _____
5. Do you have a national consumer committee where you discuss COPOLCO issues?
 - 5 a) If yes, please tick the member categories
 - government agencies (consumer protection)
 - consumer organizations
 - non government organisations (environment, child protection etc.)
 - industry
 - research organizations
 - certification bodies
 - academia
 - other [please state.....]

5 b) If yes, do you have a nominated expert / representative to participate in ISO/COPOLCO meetings and events?

5 c) If yes which category above does he/she come from?

6. How do you share information about ISO/COPOLCO with the NSB and the NSB CEO?

- through the NMC
- through the nominated expert
- directly from ISO COPOLCO secretariat
- other [please state.....]

7. Do you have any suggestions on improvements for ISO/COPOLCO in relation to its work based on its Terms of Reference?

8. What types of information about ISO/COPOLCO, and frequency of dissemination, do you prefer?

Next steps for the TG and Chairs Group:

1. To compile the results of the questionnaire
2. Chairs group will look into these responses and develop action plans especially communication plans and other related initiatives to improve the visibility of ISO COPOLCO's role and value to ISO members and consumers.
3. The Chair's Group will propose: recommendations, communication materials, communication plan among other actions for the COPOLCO's approval and
4. Carry out trials and launch the programme with the support of the ISO CS Communication team

COPOLCO Resolution x/2016

Visibility of COPOLCO within the ISO system

COPOLCO

notes the report of the COPOLCO Chair appearing at COPOLCO N205/2016,

requests the Chair's Group to make recommendations for approval at the 2017 COPOLCO meeting.

Annex: Proposed timetable



TIMETABLE FOR DEVELOPING THE VISIBILITY PROGRAMME

Actions	TG / CG/ members	May-16	Jun-16	Jul-16	Aug-16	Sep-16	Oct-16	Nov-16	Dec-16	Jan-17	Feb-17
1. To refine a set of questions to be sent to all ISO COPOLCO members	TG / CS*										
ISO COPOLCO members will be encouraged to respond to these questions in consultation with their NSB CEOs or person/s assigned to oversee the NSBs participation in ISO COPOLCO; indicators how effective ISO COPOLCO membership was to fit NSB's goals. etc.	members										
3. Chairs group will look into these responses and develop action plans especially communication plans and other related initiatives to improve visibility of ISO COPOLCO's role and value to ISO members and consumers.	CG / CS					WebEx					
4. Propose: recommendations, communication materials, communication plan among others for the Chair's Group approval and	CG/ CS										
5. Carry out trials and launch the programme with the support of the ISO CS Communication team	CG/ CS										

*ISO COPOLCO Secretary



International Organization for Standardization
Organisation internationale de normalisation
Международная организация по стандартизации

AGENDA ITEM 7 STRATEGY IMPLEMENTATION FOR ISO/COPOLCO



AGENDA ITEM 7 STRATEGY IMPLEMENTATION OF ISO/COPOLCO

COPOLCO ACTION: Members are invited to :

- comment/approve the report,
- comment on interactions with other organizations within and outside ISO, and
- approve/comment on the draft ISO Strategies implementation at Annex.

The ISO Strategy 2016-2020 lists 6 strategic directions i.e.:

1. ISO Standards used everywhere
2. Develop high-quality standards through ISO's global membership
3. Engage stakeholders and partners
4. People and organization development
5. Use of technology
6. Communication

Developing high quality standards requires effective engagement of various stakeholders. Effective engagement ensures that the standards developed are the preferred reference or tools among these stakeholders and their stakeholders. Thus standards developed should essentially meet stakeholders' needs: perhaps to solve safety and performance issues, help comply with regulatory requirements, improve productivity and market access, solutions for sustainability issues etc. Stakeholders may be the ones requesting a standard, drafting standards, using the standard or benefiting from the use of standards.

ISO and its members should continue to seek and improve engagement with stakeholders to realize the ultimate aim of the strategy of ISO standards used everywhere.

ISO's policy development committees (or PDCs) are uniquely positioned to support effective stakeholder engagements as they seek to improve the position of underrepresented stakeholders or stakeholders with limited resources, as through the ISO Committee on Developing Country matters or DEVCO. Consumers (and the general public) stand to benefit a lot from compliance with standards which are developed taking their interests into account.

Those who represent consumer interests such as consumer protection agencies, consumer organizations, public interest groups and individuals should be engaged more effectively if consumers are expected to see the benefit of standards and support demand for goods and services which comply with these standards.

The ISO Committee on consumer policy, or ISO/COPOLCO, is tasked with addressing consumer issues and needs in international standards development. It currently has a liaison relationship with ANEC, CI, IEC, OECD, OIML and a close network with AP COPOLCO, ARSO/COCO, and COPANT.

ISO DEVCO and the ISO Committee on Conformity Assessment, or ISO CASCO, exchange reports on matters of interest to each other with ISO COPOLCO. These reports appear in each other's plenary and relevant working groups documents – often taken as read.

The ISO/Academy was established to support, among others, research and capacity building needs of ISO members in international standards development and related activities. ISO COPOLCO has twice been supported for capacity building activities in 2015: training in Geneva (May 2015) and training in Brazil in conjunction with CI Congress (November 2015). It also received some support for COPOLCO's training seminar held during the ARSO COCO meeting (August 2016).

Recently ISO approved an MoU with the South Asian Regional Standards Organisation (SARSO) and sharing of updates and information of ISO/COPOLCO and other PDCs is included.

ISO is also a dialogue partner with the ASEAN Consultative Committee on Standards and Quality or ACCSQ.

ISO has developed regional engagement strategies. One of the approaches is the establishment of an office in Singapore – currently operational.

Developing high quality standards is highly dependent upon effective engagement and involvement of stakeholders and partners of ISO and therefore ISO/COPOLCO is key where consumers are concerned.

ISO COPOLCO's ability to effectively interact with partner / liaison organizations and members to complement its (limited) resources and outreach initiatives, improves the value of ISO/COPOLCO to its members (essentially NSBs) to bring benefits to consumers in areas where the NSBs operate.

The strategies referring to People and organization development, Use of technology and Communication, may refer to supporting activities to enable ISO (or ISO/COPOLCO in this case) to engage its stakeholders and partners better to ensure that good quality standards (which fulfil needs of consumers and the general public) are developed and used 'everywhere'.

The document on Strategy implementation for ISO/COPOLCO was developed to:

1. Ensure that ISO/COPOLCO represents consumers' interests through consumer representatives at ISO/COPOLCO in making the relevant international standards meet consumer needs and well-being
2. Provide the relevant support to members of ISO/COPOLCO in order for them to represent their consumer stakeholders effectively in national, regional and international standards development through:
 - a. Capacity building (people development), i.e. Technical knowledge and interpretation; research, training, channels to leverage on available funding etc.,
 - b. Use of technology, i.e. WebEx, media tools, mobile communication applications etc., and

- c. Communication i.e. forums (national, regional, international), workshops (national, regional, international), use of social media, mails, WebEx, webinars, TEDX, etc.
3. Align ISO/COPOLCO's initiatives and activities in line with the ISO Strategies implementation with the aim that ISO COPOLCO is not regarded as an added task, BUT an indispensable part of ISO and material for ISO and its members to use realizing the strategies.

To facilitate realization of the above aims each strategy is followed by action plans, timelines and indicators.

The ISO COPOLCO Secretariat assists in reporting to members on progress. However, working group convenors and Chair's Group members are responsible for providing relevant inputs to facilitate annual or periodic reporting to Council and other forums.

About ISO COPOLCO

It is one of the policy development committees (PDCs) which advises ISO Council. Other PDCs are:

1. ISO Committee on developing country matters (ISO/DEVCO)
2. ISO Committee on conformity assessment (ISO/CASCO)

How does ISO/COPOLCO work?

- To **study means** of helping consumers to benefit from standardization, (*e.g. research, scoping paper, NWIP, justification paper, etc.*) and
 - means of improving consumer participation in national and international standardization (*e.g. training, technical papers / impact papers, position papers and exploring and informing of relevant funding opportunities*)

- To **provide a forum** for the exchange of information on the experience of consumer participation in the development and implementation of standards in the consumer field, and on other questions of interest to consumers in national and international standardization.
 - *Workshop and Plenary*
 - *Working groups*
 - *Chair's group*
 - *WebExes*
 - *Training*

- To **advise ISO Council**
 - as to the consolidated viewpoints of consumers on matters relevant to ISO's current and potential standardization and conformity assessment work (*communication with CASCO, DEVCO, TMB, WSC members such as IEC, ITU and those outside ISO such as ICPEN, OECD, CODEX, UNCTAD, etc.*)
 - on the need for new or revised policies or actions within ISO as they relate to consumers' needs (*governance, procedures and TORs, statutes, ISO Directives etc.*).

Structure:



Liaison Members:

CI
 OECD
 ANEC
 OIML

Impact:

1. To study means of helping consumers to benefit from standardization

Information on impact of certain standards on consumer protection (safety, health and economy) – recent examples of areas include the collaborative economy, digital printing, IEC standards on electric toys, toy safety standards, unit pricing and consumers in the Internet of Things and relevant standards.

2. To provide a forum

Forums lead to new standards, new areas of standardization, communication with ISO TCs working on standards that have an impact on consumers' safety security, health and economic well-being, communication to standards or organizations outside ISO, etc., revision of standards and guides etc. monitor new and emerging areas of consumer issues and areas where international standards can help.

3. To advise the ISO Council

This role led to ISO's first attempt to develop social standards, by setting up the ISO Working Group on Social Responsibility to develop ISO 26000:2010. A recent example was wider consultation for the ISO Strategies 2016-2020. COPOLCO also advises on new areas of standards development, such as in services (first joint forum in 2016 of COPOLCO/TMB on services).

Deliverables as of 2016

(Also see the Key Areas Group Handbook, N023, page 17).

Policy statements

ISO/IEC statement, *Consumer participation in standardization work*

Contributions to [ISO/IEC/ITU, Policy on Standardization and accessibility](#)

Guides

ISO/IEC Guide 14, *Purchase information on goods and services intended for consumers*

ISO/IEC Guide 37, *Instructions for use of products by consumers*

ISO Guide 41, *Packaging – Recommendations for addressing consumer needs*

ISO/IEC Guide 46, *Comparative testing of consumer products and related services – General principles.*

ISO/IEC Guide 50, *Safety aspects – Guidelines for child safety in standards and other specifications*

ISO/IEC Guide 51, *Safety aspects – Guidelines for their inclusion in standards*

ISO Guide 64, *Guide for addressing environmental issues in product standards*

Contributions to [ISO/IEC Guide 71, Guide for addressing accessibility in standards](#)

ISO/IEC Guide 74, *Graphical symbols – Technical guidelines for the consideration of consumers' needs*
ISO/IEC Guide 76, *Development of service standards – Recommendations for addressing consumer issues*
ISO Guide 82, *Guidelines for addressing sustainability in standards*

Informative Publications and Resources

[Involving consumers – Why and how: Practical guidance for standards development bodies](#)

[Your voice matters – Why consumers need to participate in standards making and how to get involved: 2003](#)

[How ISO/IEC Guides add value to international standards](#)

[The consumer and standards – Guidance and principles for consumer participation in standards development. 2003](#)

[ISO and the consumer](#)

[ISO Directory of consumer interest participation](#)

[Consumers and standards: partnership for a better world](#)

[The international language of graphical symbols eNewsletter: ISO Consumer update](#)

ISO/COPOLCO in an international standards development ecosystem

Interactions:

How about other International Standards organizations such as CODEX, ISEAL etc. which all have impact on consumers?

Members are welcomed to provide comments on the above figure i.e. whether to pursue some form of relationship with those in red text.

**How COPOLCO can support
the ISO 2016-2020 Strategy –
Version 2016-03-22**

ISO Strategy 2016-2020 Reference to the strategic directions in the strategy	COPOLCO activities support to the ISO Strategy	Responsible	Target	Status
1 ISO standards used everywhere				
<p>1.1 Producing International standards in a clear, understandable language, that are easy to read and user-friendly</p>	<p>1.1.1 Inform COPOLCO members on relevant consumer standards during enquiry (ISO/DIS) and encourage members to comment on the drafts, (note: when it comes to a plain and clear language. Consumers can easily uptake this role in the standards development.) and where possible (given availability of resources) produce communication materials for consumer representatives and NSBs, or use/ implementation / impact of a published standard or new work etc</p> <p>1.1.2 Inform COPOLCO members about the “plain-language-initiative” in ISO (reference. Norma McCormick’s report on ISO/TC 223 activities where this committees is one of 3 test committees for plain language)</p> <p>1.1.3 Get inputs from CS on how many of ISO COPOLCO generated standards have been referenced,</p>	<p>COPOLCO secretariat</p> <p>WG 2 Key areas for consumers</p> <p>WG Consumer participation</p> <p>Relevant WGs (depending on work area)</p> <p>COPOLCO Secretariat and CS</p> <p>COPOLCO secretariat and CS (TMB?)</p> <p>COPOLCO Secretariat, ISO/CS and TMB</p>	<p>Running item 2016-2020</p>	

ISO Strategy 2016-2020 Reference to the strategic directions in the strategy	COPOLCO activities support to the ISO Strategy	Responsible	Target	Status
	used, adopted, sold etc review ICS for consumer facing standards			
1.2 Enabling ISO members to successfully reach their markets, promote the use of ISO standards and deliver ISO content to their customers	Inform COPOLCO members on relevant and ongoing standardization work, published standards relevant to consumers their impact / benefits and how they can be used.	COPOLCO Secretariat WG 2 Key areas for consumers and relevant WGs (depending on work area)	Running item 2016-2020	
1.3 Increasing the uptake of standards as business performance tools	Explain benefits of conformity to standards (related to consumer issues) from a consumer point of view for economic, health and values aspects	COPOLCO secretariat WG 2 Key areas for consumers (all relevant WGs under COPOLCO)		
1.4 Identifying and meeting the changing needs of customers with a focus on how they would like to use and access ISO standards	1.4.1 Identify new and emerging issues and explore opportunities for relevant standards deliverables to address these issues 1.4.2 Address the needs of consumers related to new and ongoing standardization work through the COPOLCO workshop each year in May/June. 1.4.3 Address the consumers issues	COPOLCO secretariat and COPOLCO Chair group (Workshop theme) Relevant WGs (depending on work area) Members (regional organizations ARSO, COPANT, AP COPOLCO <i>also newly approved SARSO</i>) – coordinated by	May/June: Arrange a COPOLCO workshop addressing consumer needs in ISO standardization area or new area July: Ask COPOLCO members for workshop theme for the following year November: Chair group develops workshop programme for the	

ISO Strategy 2016-2020 Reference to the strategic directions in the strategy	COPOLCO activities support to the ISO Strategy	Responsible	Target	Status
	<p>related to ongoing standardization work within a Key Area</p> <p>1.4.4 Encourage information exchange among COPOLCO members on research and reports on emerging consumer issues in their country or regions.</p>	COPOLCO Secretariat and Chair's Group	following year based on members input	
2 Develop high-quality standards through ISO's global membership				
<p>2.1 Developing market-relevant standards that address the needs of industry, regulators, consumers and other stakeholders.</p>	<p>2.1.1 Produce justification studies for NWIP coming from COPOLCO. Suggest new activities in ISO and address consumer needs when ISO is developing new fields, including participating in the development of ISO and WSC workshops in subject areas affecting consumers (e.g. services, smart cities). .</p> <p>2.1.2 Monitor and update "New activity template" to justify COPOLCO proposals.</p> <p>2.1.3 Develop mechanism to identify and improve outreach to relevant stakeholders (regulators, business sector, stakeholders). This is a WG-wide approach.</p> <p>2.1.4 For NWI approved by COPOLCO:</p>	<p>Relevant COPOLCO WG CAG</p> <p>Chair's Group and COPOLCO Secretariat initiatives under MCI (COPOLCO Secretariat and CS</p>	<p>Running item 2016-2020</p> <p>2017</p> <p>2018</p> <p>2017</p> <p>Running item.</p>	

ISO Strategy 2016-2020 Reference to the strategic directions in the strategy	COPOLCO activities support to the ISO Strategy	Responsible	Target	Status
	<p>Develop mechanism to identify and improve outreach to relevant stakeholders (regulators, business sector, stakeholders).</p> <p>2.1.5 Encourage consumer participation in ongoing standardization work relevant for consumers by training, awareness (ISO Connect; Facebook, Liaisons, CI, ANEC and other international organizations).</p> <p>2.1.6 Establish contact and liaison with regional consumer affairs / protection networks (e.g. OAS/ ARSO COCO, SARSO, CIS and ASEAN CCP).</p> <p>2.1.7 Advocate and share information on sustainable financial/policy models for supporting consumer representatives. (Encourage COPOLCO delegates to register on ISO Directory of consumer interest participation during June 2016 meeting)</p> <p>2.1.8 Contribute to work in SPC and TMB on review the process for introducing new work into ISO.</p>	<p>Relevant WGs (depending on work area) with the additional help from MCI (marketing, communication and information programme under the ISO Strategies)</p> <p>COPOLCO Chair's Group and Secretariat and ISO/CS</p> <p>WG Consumer participation and training.</p> <p>Work with ISO CS MCI group</p> <p>Chair's Group and COPOLCO Secretariat</p>	<p>Running item, but a target for 2017: 70 % of COPOLCO members</p>	

ISO Strategy 2016-2020 Reference to the strategic directions in the strategy	COPOLCO activities support to the ISO Strategy	Responsible	Target	Status
2.2 Strengthening the ability of ISO committees and their leaders to build consensus among experts from different countries, cultures and stakeholders categories	Promote greater use of the ISO/IEC Guides, considering making them mandatory at secretary and chairs training and workshop sessions. Plug into regional engagement initiatives.	NSBs WG Participation and Training COPOLCO Secretariat / ISO Academy		
3 Engage stakeholders and partners				
3.1 Strengthening the input of as many members and their stakeholders as possible in ISO development process including under-represented groups	3.1.1 Encourage consumer participation in ongoing standardization work relevant for consumers 3.1.2 Engage liaison organisations and partners to promote input from developing country members 3.1.3 Inform COPOLCO members on important consumer standards during enquiry in order to gain consumer input during the	WG Consumer participation and training WG Key Areas and CP		

ISO Strategy 2016-2020 Reference to the strategic directions in the strategy	COPOLCO activities support to the ISO Strategy	Responsible	Target	Status
	development of a standard (also see 1.1.1)			
4 People and organization development				
4.1 Governance				
4.2 Capacity building	Work with ISO Academy to identify training priorities for consumer interests at national and regional organisations and the Singapore office	CAG, COPOLCO secretariat and ISO Academy		
5 Technology				
6 Communication				
6.1 Developing high-quality effective and easy-to-understand communication materials in a range of media for use by ISO members	<p>6.1 Evaluate, and revise if necessary, COPOLCO brochures and material</p> <p>6.2 Evaluate and change if needed, the COPOLCO area on www.iso.org</p> <p>Explore use of IT to reach out to members and engage with members effectively – beginning</p>	<p>COPOLCO Secretariat and Chair's Group (work with the MCI and IT group)</p> <p>WG Consumer Participation</p>		

ISO Strategy 2016-2020 Reference to the strategic directions in the strategy	COPOLCO activities support to the ISO Strategy	Responsible	Target	Status
	with quarterly webex. Explore use of webinars etc			
6.2 Helping members build strong relationships with their government, local business and leaders of key stakeholder groups	6.2.1 Facilitate networking between consumer stakeholders and ministries of consumer affairs by encouraging participation at COPOLCO workshops and plenary meeting events	COPOLCO Secretariat CAG (with CS on Regional Engagement Initiatives of ISO)		
7 Ensuring success				
7.1 ...specific plans for its policy work in areas such as consumers....	7.1.1 Develop a COPOLCO action plan to support ISO strategy (= THIS DOCUMENT)	COPOLCO Secretariat and Chair's Group		
7.2 ...measure performance of the organization in its implementation of the Strategy	Develop annual programme and milestones for COPOLCO action plan to support ISO strategy, measure performance and report to ISO annually Develop clear governance procedures for COPOLCO – for chairs, CAG members and convenors (ToR, nominations, selection etc)	COPOLCO Secretariat and Chair's Group	Draft by July 2016 And confirm by November 2016 November 2016	



International Organization for Standardization
Organisation internationale de normalisation
Международная организация по стандартизации

AGENDA ITEM 8 2016 WORKSHOP – RESULTS AND FOLLOW-UP ACTIONS



AGENDA ITEM 8 2016 COPOLCO WORKSHOP – RESULTS AND FOLLOW-UP ACTIONS

About the 2016 workshop

COPOLCO ACTION COPOLCO is invited to consider actions to recommend for future development within COPOLCO or ISO, based on workshop conclusions.

A great deal of discussion has taken place on services standardization, both within and outside the ISO system, on many levels. For good reason: the value added by trade in services is over 70% of the world's economy¹. Therefore the ISO Council identified developing and implementing a strategy on service standardization as one of its 2016 Priority Achievements, mandating the Technical Management Board to hold an international workshop to reach this objective. This year, ISO/COPOLCO is holding its annual workshop as part of this general ISO workshop, to facilitate exchange of views with other representatives of the ISO community and to add the consumer voice to the international dialogue which will field-test [ISO's strategy on standardization of services](#).

Role of participants

After the workshop, COPOLCO participants are invited to join an open discussion on Wednesday morning, 15 June, to consider outcomes of the workshop from the consumer point of view. Workshop conclusions will be discussed further during the Plenary.

The workshop programme will have a mix of presentations and interactive sessions, including small groups, break-out sessions and panel debates. The detailed programme will be available in the coming weeks. All are invited to participate actively in the discussion.

Please find the draft programme at Annex 1.

A list of past workshops is at Annex 2.

Annex 1: Draft 2016 workshop programme

Annex 2: List of past workshops

¹ World Bank 2013, <http://data.worldbank.org/indicator/NV.SRV.TETC.ZS/countries?display=graph>

work shop



Global services ISO standards as solutions



13-14 June 2016, Geneva, Switzerland



13 June 2016

Day 1

13:00-13:10

Welcome and opening

Overview of the workshop and its objectives

ISO Secretary General and invited guests (tbc)

13:10-13:30

Keynote speech

The importance of international trade in services and the role of standards

WTO representative

13:30-15:30

Regional/national solutions: lessons learned and challenges faced

- Standardization initiatives already launched in the services field
- Regional/National challenges faced in tackling emerging service standardization issues

6 speakers from ISO member bodies (representing different regions)

15:30-16:00

Coffee break

16:00-17:00

Roundtable discussions – stakeholder expectations and needs

The plenary will split up into small groups to discuss questions such as:

- What is your understanding of the term “service”?
- What elements are most important/expected in the provision of a service?
- Which types of standards would help services to be purchased or provided internationally?
- What service standards priorities exist in your country/sector and why?
- How can ISO International Standards help?

All participants

17:00-17:30

Reporting back from roundtable discussions and close of day 1

Rapporteurs from each of the small groups will report on the main points discussed and any conclusions from the previous session.

Rapporteurs

17:30-19:30

TMB/COPOLCO sponsored social event for all workshop attendees

14 June 2016

Day 2

09:00-09:10 Opening

Summary of day 1 conclusions and review of program for day 2/instructions

Workshop moderator

09:10-10:15 Helpful ISO tools for designing, assessing and measuring service performance, quality and excellence

- **Design:** ISO/IEC Guide 76 – *Development of service standards – Recommendations for addressing consumer issues*
- **Measurement:** For example, measurement and monitoring of customer satisfaction (ISO 10004).
- **Delivery:** For example, standards for tourism, water, or financial services. Exact topic tbc.
- **Confidence:** What is CASCO doing on conformity assessment of services (including ISO/IEC 17028 an example of a certification scheme for services)

Presentations by experts involved in the development or application of ISO standards for services

10:15-10:45 Coffee break

10:45-12:00 Panel discussion

Each panelist will address:

- What do the users expect in relation to the provision of services?
- Good example(s), bad example(s) in service provision and the impact to them as users.
- How could ISO standards help in the provision of services?

Panelists will represent a range of different perspectives:

- *User of business to business services (a company representative)*
- *A user of business to consumer services (a consumer representative)*
- *A user of public services, government to business, business to government or government to consumer (a government representative)*
- *A developing country user of services*

12:00-13:00 Lunch

13:00-15:00 Breakout sessions:

- 1) **Business-to-business providers and users of services**
- 2) **Business-to-consumer providers and users of services**
- 3) **Public services and highly-regulated services**
- 4) **Perspectives and requirements of developing countries for service standards**

Development of conclusions and recommendations

- *Speakers (tbc)*

15:00-15:30 Coffee break

15:30-16:15 Reports from breakout sessions

Short summaries of the conclusions from the 4 breakout sessions

- *Speakers from the breakout sessions*

16:15-17:15 Moderated discussion: ISO issues, priorities and solutions

Development of consensus on recommendations from previous workshop sessions

Discussion on questions such as:

- How can ISO better engage with stakeholders from services sectors, including SMEs?
- What are areas/sectors of further interest for the ISO system?

17:15-17:30 Summary and closing

Summary of the workshop. Announcements and acknowledgements

Workshop moderator and ISO representatives

About the workshop

Discover the potential for services standardization in ISO!

As international trade in services becomes an ever greater driver of economic growth, both in developed and developing countries, market demand for standards to ensure the quality of service delivery is steadily increasing.

How can ISO step up to meet this demand?

Join us for this interactive workshop to explore how International Standards can best help design, assess and measure service excellence, benefitting both businesses and consumers.

This is an opportunity to share expectations, experiences, and best practices related to services standardization with a mix of standards developers, experts in trade and development from international organizations or governments, representatives of consumer organizations, stakeholders from the services sectors, and more.

Venue

The **Mövenpick Hotel**, Route de Pré Bois 20, CH-1215 Geneva.

Registration

To register for this event please go to:

<http://www.cvent.com/d/xfqx2k>

There are limited places for this event.

Registration is on a first come, first served basis.

About ISO

ISO (International Organization for Standardization) is an independent, non-governmental international organization with a membership of 162* national standards bodies. Through its members, it brings together experts to share knowledge and develop voluntary, consensus-based, market-relevant International Standards that support innovation and provide solutions to global challenges.

ISO has published more than 21 000* International Standards and related documents covering almost every industry, from technology to food safety, to agriculture and healthcare.

For more information, please visit www.iso.org.

International Organization for Standardization

ISO Central Secretariat
Chemin de Blandonnet 8, CP 401
CH – 1214 Vernier, Geneva,
Switzerland

iso.org

© ISO, 2016
All rights reserved

LIST OF COPOLCO WORKSHOPS 1979 – 2016

- 1979 *Product safety*, Geneva, Switzerland
- 1980 *Consumer information*, Tel Aviv, Israel
- 1981 *Packaging and the consumer*, Paris, France
- 1982 *Energy conservation and the consumer: The role of standardization*, Geneva, Switzerland
- 1983 *Standards and child safety*, Copenhagen, Denmark
- 1984 *Certification and the consumer: Present systems and future trends*, Geneva, Switzerland
- 1985 *Sports – more fun, less risk: A challenge for international standardization*, Berlin, Germany
- 1986 *The car and the consumer – The impact of standards*, Göteborg, Sweden
- 1987 *Burning issues – Towards greater public consumer needs*, Toronto, Canada
- 1988 *Quality in the market place – meeting consumer needs*, Geneva, Switzerland
- 1989 *Good safe food – How can standards help?*, Ankara, Turkey
- 1990 *World standards: A good bargain for consumers*, Florida, USA
- 1991 *Consumer needs in environmental labelling and product assessment*, Helsinki, Finland
- 1993 *Preventing accidents and promoting safety – The role of standardization*, Geneva, Switzerland
- 1994 *Information technology and telecommunications – Global standards serving the consumer*, The Hague, Netherlands
- 1995 *Services – A challenge for international standardization*, Beijing, China
- 1996 *Conformity assessment: meeting consumer needs*, Geneva, Switzerland
- 1997 *Consumers in standards work*, London, United Kingdom
- 1998 *Product labelling – its role in trade and standardization*, Tunis, Tunisia
- 1999 *Meeting the needs of ageing populations – Enhancing the quality of life through standards*, Washington D.C., USA
- 2000 *Consumer protection in the global market – Using standards as a safeguard*, Kyoto, Japan
- 2001 *Improving services for consumers – How can standards help?*, Oslo, Norway
- 2002 *Corporate social responsibility – Concepts and solutions*, Port of Spain, Trinidad & Tobago
- 2003 *Consumer confidence and the role of standards – Principles and ethical practices*, Bangkok, Thailand
- 2004 *Regulation, co-regulation, or deregulation: Who's at risk? Legislation and standards, partners in consumer protection*, Prague, Czech Republic
- 2005 *A safer world for consumers – How can standards help?*, Toronto, Canada
- 2006 *How can environmental standards promote sustainable consumption?*, Kuala Lumpur, Malaysia
- 2007 *Can consumers rely on fair trade claims?*, Salvador de Bahia, Brazil
- 2008 *Standards for a sustainable world: How can consumers influence a sustainable energy future?*, Seoul, Republic of Korea
- 2009 *Interoperability: does it fit, will it work, and can standards help?*, New Delhi, India
- 2010 *Restoring consumer confidence in global financial services – Can standards help?*, Bali, Indonesia
- 2011 *Homes for tomorrow – Building through standards*, London, United Kingdom
- 2012 *How do consumers know what they are getting?*, Nadi, Fiji
- 2013 *Innovating food products – How can standards ensure consumer protection?*, Valletta, Malta
- 2014 *Building confidence in a business-to-consumer relationship: roles and expectations*, Milan, Italy
- 2015 *The connected consumer in 2020: Empowerment through standards*, Geneva, Switzerland
- 2016 *Global services – ISO standards as solutions*, Geneva, Switzerland



International Organization for Standardization
Organisation internationale de normalisation
Международная организация по стандартизации

AGENDA ITEM 9 CONSUMER PRIORITIES IN STANDARDIZATION ON SERVICES

AGENDA ITEM 9 CONSUMER PRIORITIES IN STANDARDIZATION OF SERVICES

COPOLCO ACTION: Members are invited to comment/approve the report and draft resolution.

As an action to fulfill its mandate to investigate consumers' priorities in services, ISO/COPOLCO Working Group 18 "Consumer issues in standardization of services" launched a survey to investigate service standardization needs from the consumer's point of view from 21 March to 21 April 2016. 59 COPOLCO members responded to the survey. The survey result analysis for each question is as follows:

Q.1:"Which services cause the most complaints for consumers in your country?"

39 COPOLCO members gave feedback on this question. The services areas which cause the most complaints for consumers mainly focus on telecommunication services (including mobile phones, networks), financial services (including banking, insurance, debt), public services (including power, water and energy supply, public facilities, municipal services), transportation services (including public transportation, airline, taxi), health care services (including home care, medical care), online shopping services (including e-commerce service), tourism and leisure services (including travel, TV subscription), retail services (including food, product and commodity supply), real estate and intermediary services (including real estate, property services), life services (including beauty services, express services, catering services, parking services), and automobile services.. Figure 1 illustrates the quantity for services sectors which cause the most complaints as reported by COPOLCO members.

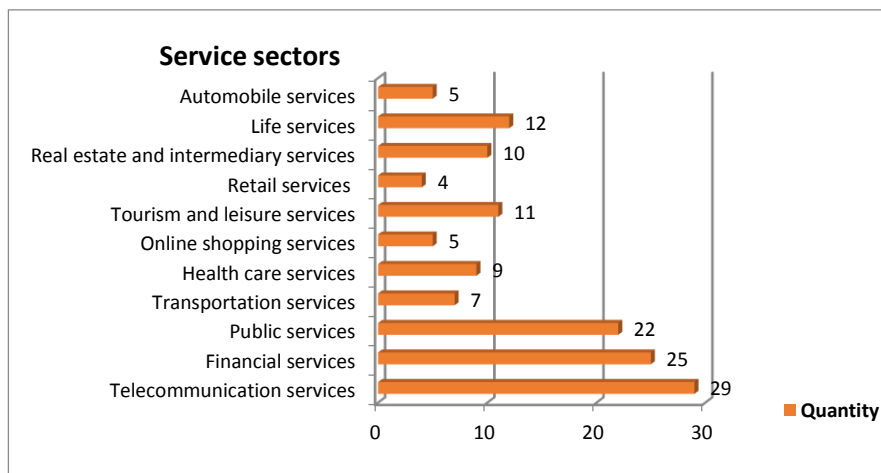

Fig.1 Breakdown of services sectors generating complaints as reported by COPOLCO members

Q.2:"Which services cause the greatest loss and/or harm for consumers in your country?"

35 COPOLCO members gave feedback on this question. The services which cause the greatest loss and/or harm mainly focus on telecommunication services, health care services, financial services, public services, tourism and leisure services, retail services, online shopping services, real estate and intermediary services, life services, transportation services and automobile services. Figure 2 illustrates the quantity for services sectors which cause the greatest loss and/or harm as reported by COPOLCO members.

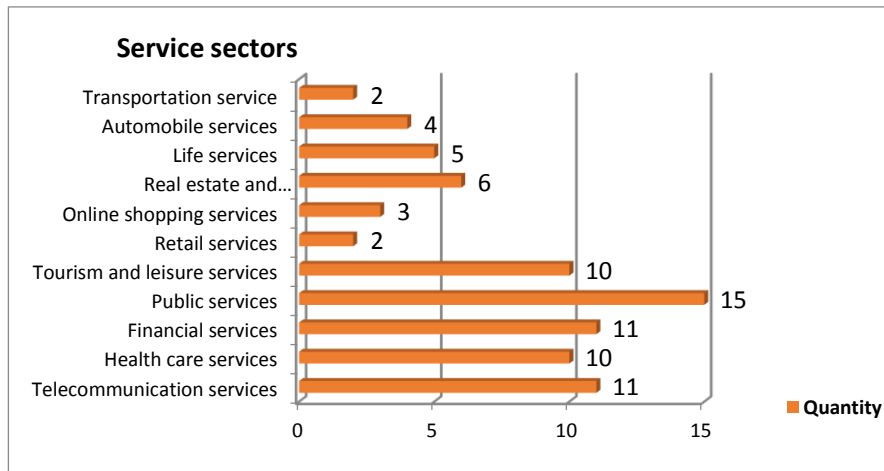

Fig.2 Breakdown of services sectors generating the greatest loss and/or harm as reported by COPOLCO members

Q.3:"What national standards exist for services that you feel might be relevant and useful internationally (e.g. cross-border issues)?"

20 COPOLCO members gave feedback on this question. Some countries mention the areas and some countries mention the specific national service standards. The areas mainly focus on quality management, tourism services, learning services, health care services, housing services, financial services, automobile service and repair and maintenance services.

Q.4:"What other services do you consider to be a priority for international standardization?"

26 COPOLCO members gave feedback on this question. The priorities for international standardization mainly focus on telecommunication services, health services, financial services, transportation services, tourism services, life services, online shopping services, vulnerable consumer services and collaborative economy services. Figure 3 illustrates the quantity for priorities for international standardization as reported by COPOLCO members.

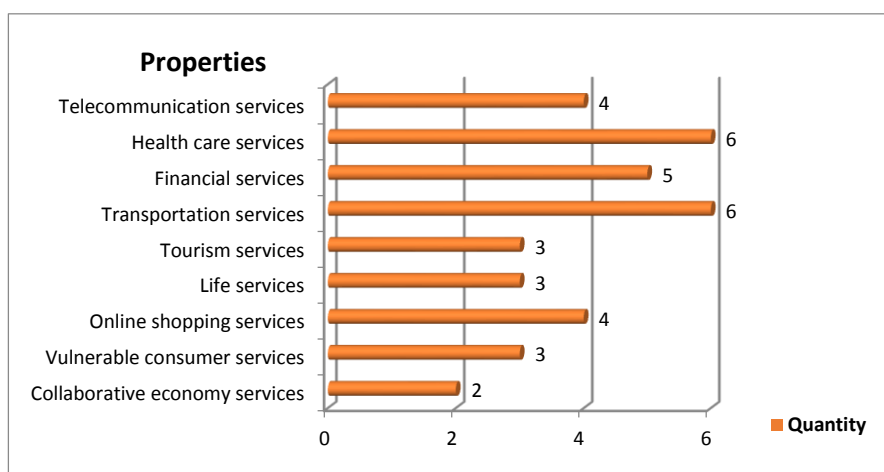

Fig.3 Breakdown of priorities for international standardization as reported by COPOLCO members

Q.5:"What are the key issues for consumers in the provision of a service?"

37 COPOLCO members gave feedback on this question. The key issues focus on disclosure, timeliness, convenience, price, quality, fairness, safety, privacy, reliability and complaint handling. Figure 4 illustrates the quantity for key issues for consumers in the provision of a service as reported by COPOLCO members.

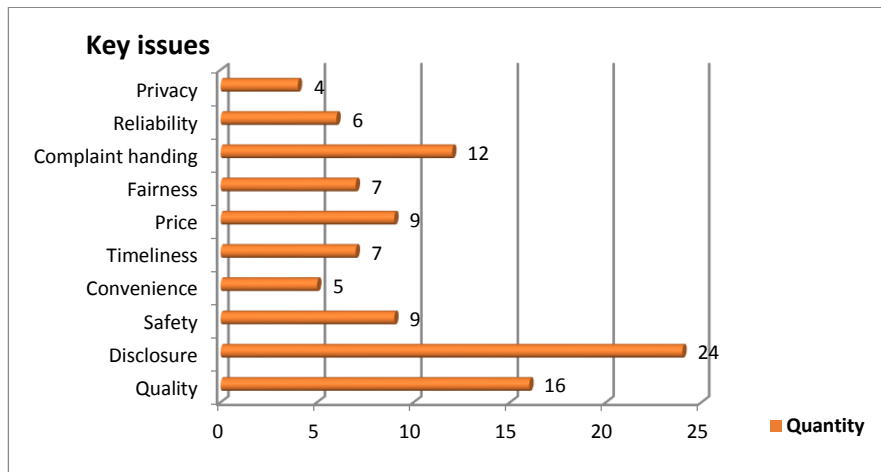

Fig.4 Breakdown of key issues for consumers in the provision of a service as reported by COPOLCO members

The result of voting appears at **Annex**

Draft resolution X/2016

COPOLCO

notes that the usefulness of the information provided by the survey to improving understanding of standardization needs,

requests Working Group 18 to consider the key issues of service provision put forward by COPOLCO members when redrafting ISO/IEC Guide 76.

requests Working Group 18 to develop recommendations for consideration by COPOLCO, based on the results of the survey and outcomes of the workshop, *Global services – ISO standards as solutions*.

Annex: Results of the survey on service standardization needs

Result of voting

Ballot Information

Ballot reference	COPOLCO N195
Ballot type	CIB
Ballot title	Survey to investigate service standardization needs from the consumer's point of view
Opening date	2016-03-21
Closing date	2016-04-21
Note	<p>Dear COPOLCO Members,</p> <p>ISO/COPOLCO Working Group 18, <i>Consumer issues in standardization of services</i>, is initiating a survey to investigate service standardization needs from the consumer's point of view, in accordance with its terms of reference (see Resolution 3/2015 and COPOLCO 13/2015).</p> <p>The outcome of this survey will be important input into the discussion during the forthcoming workshop, <i>Global services: ISO standards as solutions</i>, that will take place in Geneva on 13-14 June 2016. It will also help shape the COPOLCO plenary meeting's decisions on 17 June.</p> <p>As a result, we would appreciate your taking the time to consult with national stakeholders and to answer the questions below, by 21 April 2016.</p> <p>We thank you in advance for your attention and timely response.</p> <p>Yours faithfully,</p> <p>Dana Kissinger-Matray Secretary of COPOLCO</p>

Member responses:**Votes cast (55)**

Argentina (IRAM)
Australia (SA)
Austria (ASI)
Bahrain (BSMD)
Barbados (BNSI)
Botswana (BOBS)
Brazil (ABNT)
Canada (SCC)
Chile (INN)
China (SAC)
Colombia (ICONTEC)
Costa Rica (INTECO)
Czech Republic (UNMZ)
Denmark (DS)
Egypt (EOS)
Finland (SFS)
Germany (DIN)
Ghana (GSA)
India (BIS)
Indonesia (BSN)
Iran, Islamic Republic of (ISIRI)
Ireland (NSAI)
Israel (SII)
Jamaica (BSJ)
Japan (JISC)
Kenya (KEBS)
Malawi (MBS)
Malaysia (DSM)
Malta (MCCAA)
Mauritius (MSB)
Mexico (DGN)
Namibia (NSI)
Netherlands (NEN)
Norway (SN)
Pakistan (PSQCA)
Panama (COPANIT)
Peru (INACAL)
Portugal (IPQ)
Saudi Arabia (SASO)
Serbia (ISS)
Singapore (SPRING SG)
Slovenia (SIST)
South Africa (SABS)
Spain (AENOR)
Sweden (SIS)
Switzerland (SNV)
Thailand (TISI)
Trinidad and Tobago (TTBS)
Tunisia (INNORPI)
Turkey (TSE)
United Arab Emirates (ESMA)
United Kingdom (BSI)
United States (ANSI)
Uruguay (UNIT)
Zimbabwe (SAZ)

Comments submitted (3)	Armenia (SARM) Saint Lucia (SLBS) Viet Nam (STAMEQ)
Votes not cast (15)	Algeria (IANOR) Bangladesh (BSTI) Bulgaria (BDS) Cyprus (CYS) Ecuador (INEN) Fiji (DNTMS) France (AFNOR) Italy (UNI) Kazakhstan (KAZMEMST) Korea, Republic of (KATS) Oman (DGSM) Romania (ASRO) Russian Federation (GOST R) Sri Lanka (SLSI) Sudan (SSMO)

Questions:	
Q.1	"Which services cause the most complaints for consumers in your country?"
Q.2	"Which services cause the greatest loss and/or harm for consumers in your country?"
Q.3	"What national standards exist for services that you feel might be relevant and useful internationally (e.g. cross-border issues)?"
Q.4	"What other services do you consider to be a priority for international standardization?"
Q.5	"What are the key issues for consumers in the provision of a service?"

Votes by members	Q.1	Q.2	Q.3	Q.4	Q.5
Argentina (IRAM)	Services generating the most complaints are (please comment):	The services that cause the greatest loss/harm are (please comment):	Existing national standards are (please comment):	Not applicable	The key issues are (please comment):
Australia (SA)	Services generating the most complaints are (please comment):	The services that cause the greatest loss/harm are (please comment):	Existing national standards are (please comment):	Other priority services are (please comment):	The key issues are (please comment):
Austria (ASI)	No information	No information	No information	No information	No information
Bahrain (BSMD)	Services generating the most complaints are (please comment):	The services that cause the greatest loss/harm are (please comment):	Not applicable	No information	The key issues are (please comment):
Barbados (BNSI)	Services generating the most complaints are (please comment):	The services that cause the greatest loss/harm are (please comment):	No information	No information	The key issues are (please comment):

Botswana (BOBS)	Services generating the most complaints are (please comment):	The services that cause the greatest loss/harm are (please comment):	Existing national standards are (please comment):	Other priority services are (please comment):	The key issues are (please comment):
Brazil (ABNT)	No information	No information	No information	No information	No information
Canada (SCC)	Services generating the most complaints are (please comment):	The services that cause the greatest loss/harm are (please comment):	Existing national standards are (please comment):	Other priority services are (please comment):	The key issues are (please comment):
Chile (INN)	Services generating the most complaints are (please comment):	The services that cause the greatest loss/harm are (please comment):	No information	Other priority services are (please comment):	The key issues are (please comment):
China (SAC)	Services generating the most complaints are (please comment):	The services that cause the greatest loss/harm are (please comment):	Existing national standards are (please comment):	Other priority services are (please comment):	The key issues are (please comment):
Colombia (ICONTEC)	Services generating the most complaints are (please comment):	The services that cause the greatest loss/harm are (please comment):	Existing national standards are (please comment):	Other priority services are (please comment):	No information
Costa Rica (INTECO)	No information	No information	Existing national standards are (please comment):	No information	The key issues are (please comment):
Czech Republic (UNMZ)	Services generating the most complaints are (please comment):	The services that cause the greatest loss/harm are (please comment):	Not applicable	Other priority services are (please comment):	The key issues are (please comment):
Denmark (DS)	Services generating the most complaints are (please comment):	No information	Existing national standards are (please comment):	No information	The key issues are (please comment):
Egypt (EOS)	No information	No information	Existing national standards are (please comment):	Other priority services are (please comment):	No information
Finland (SFS)	Services generating the most complaints are (please comment):	The services that cause the greatest loss/harm are (please comment):	Not applicable	No information	The key issues are (please comment):
Germany (DIN)	Services generating the most complaints are (please comment):	The services that cause the greatest loss/harm are (please comment):	Existing national standards are (please comment):	Other priority services are (please comment):	The key issues are (please comment):

Ghana (GSA)	Services generating the most complaints are (please comment):	The services that cause the greatest loss/harm are (please comment):	Not applicable	No information	The key issues are (please comment):
India (BIS)	Services generating the most complaints are (please comment):	The services that cause the greatest loss/harm are (please comment):	Existing national standards are (please comment):	Other priority services are (please comment):	The key issues are (please comment):
Indonesia (BSN)	Services generating the most complaints are (please comment):	The services that cause the greatest loss/harm are (please comment):	Existing national standards are (please comment):	Other priority services are (please comment):	The key issues are (please comment):
Iran, Islamic Republic of (ISIRI)	Services generating the most complaints are (please comment):	The services that cause the greatest loss/harm are (please comment):	Not applicable	Other priority services are (please comment):	The key issues are (please comment):
Ireland (NSAI)	No information	No information	No information	No information	No information
Israel (SII)	No information	No information	No information	No information	No information
Jamaica (BSJ)	Services generating the most complaints are (please comment):	The services that cause the greatest loss/harm are (please comment):	Existing national standards are (please comment):	No information	The key issues are (please comment):
Japan (JISC)	No information	No information	No information	No information	No information
Kenya (KEBS)	Services generating the most complaints are (please comment):	The services that cause the greatest loss/harm are (please comment):	Existing national standards are (please comment):	Other priority services are (please comment):	The key issues are (please comment):
Malawi (MBS)	Services generating the most complaints are (please comment):	The services that cause the greatest loss/harm are (please comment):	Existing national standards are (please comment):	Other priority services are (please comment):	The key issues are (please comment):
Malaysia (DSM)	Services generating the most complaints are (please comment):	The services that cause the greatest loss/harm are (please comment):	Not applicable	Other priority services are (please comment):	The key issues are (please comment):
Malta (MCCAA)	Services generating the most complaints are (please comment):	The services that cause the greatest loss/harm are (please comment):	Not applicable	No information	The key issues are (please comment):
Mauritius (MSB)	Services generating the most complaints are (please comment):	No information	No information	Other priority services are (please comment):	The key issues are (please comment):
Mexico (DGN)	No information	No information	No information	No information	No information

Namibia (NSI)	No information	No information	Not applicable	No information	No information
Netherlands (NEN)	No information	No information	No information	No information	No information
Norway (SN)	No information	No information	No information	No information	The key issues are (please comment):
Pakistan (PSQCA)	Not applicable	No information	Not applicable	Not applicable	Not applicable
Panama (COPANIT)	Services generating the most complaints are (please comment):	The services that cause the greatest loss/harm are (please comment):	No information	No information	No information
Peru (INACAL)	Services generating the most complaints are (please comment):	No information	Not applicable	Other priority services are (please comment):	The key issues are (please comment):
Portugal (IPQ)	No information	No information	No information	No information	No information
Saudi Arabia (SASO)	Services generating the most complaints are (please comment):	The services that cause the greatest loss/harm are (please comment):	No information	Other priority services are (please comment):	The key issues are (please comment):
Serbia (ISS)	No information	No information	No information	No information	No information
Singapore (SPRING SG)	Services generating the most complaints are (please comment):	The services that cause the greatest loss/harm are (please comment):	No information	Other priority services are (please comment):	The key issues are (please comment):
Slovenia (SIST)	No information	No information	No information	No information	No information
South Africa (SABS)	Services generating the most complaints are (please comment):	The services that cause the greatest loss/harm are (please comment):	No information	No information	The key issues are (please comment):
Spain (AENOR)	Services generating the most complaints are (please comment):	No information	Existing national standards are (please comment):	No information	No information
Sweden (SIS)	No information	No information	No information	No information	No information
Switzerland (SNV)	No information	No information	No information	No information	No information
Thailand (TISI)	No information	No information	No information	Not applicable	Not applicable
Trinidad and Tobago (TTBS)	Services generating the most complaints are (please comment):	The services that cause the greatest loss/harm are (please comment):	No information	No information	The key issues are (please comment):
Tunisia (INNORPI)	No information	No information	No information	No information	No information
Turkey (TSE)	Services generating the	The services that cause the	Existing national standards	Other priority services	Not applicable

	most complaints are (please comment):	greatest loss/harm are (please comment):	are (please comment):	are (please comment):	
United Arab Emirates (ESMA)	Services generating the most complaints are (please comment):	The services that cause the greatest loss/harm are (please comment):	Existing national standards are (please comment):	No information	The key issues are (please comment):
United Kingdom (BSI)	Services generating the most complaints are (please comment):	The services that cause the greatest loss/harm are (please comment):	Existing national standards are (please comment):	Other priority services are (please comment):	The key issues are (please comment):
United States (ANSI)	Services generating the most complaints are (please comment):	The services that cause the greatest loss/harm are (please comment):	Existing national standards are (please comment):	Other priority services are (please comment):	The key issues are (please comment):
Uruguay (UNIT)	No information	No information	Not applicable	No information	No information
Zimbabwe (SAZ)	No information	No information	No information	No information	No information

Answers to Q.1: "Which services cause the most complaints for consumers in your country?"

34 x **Services generating the most complaints are (please comment):**

Argentina (IRAM)
Australia (SA)
Bahrain (BSMD)
Barbados (BNSI)
Botswana (BOBS)
Canada (SCC)
Chile (INN)
China (SAC)
Colombia (ICONTEC)
Czech Republic (UNMZ)
Denmark (DS)
Finland (SFS)
Germany (DIN)
Ghana (GSA)
India (BIS)
Indonesia (BSN)
Iran, Islamic Republic of (ISIRI)
Jamaica (BSJ)
Kenya (KEBS)
Malawi (MBS)
Malaysia (DSM)
Malta (MCCAA)
Mauritius (MSB)
Panama (COPANIT)
Peru (INACAL)
Saudi Arabia (SASO)
Singapore (SPRING SG)
South Africa (SABS)
Spain (AENOR)
Trinidad and Tobago (TTBS)
Turkey (TSE)

		United Arab Emirates (ESMA) United Kingdom (BSI) United States (ANSI)
1 x	Not applicable	Pakistan (PSQCA)
20 x	No information	Austria (ASI) Brazil (ABNT) Costa Rica (INTECO) Egypt (EOS) Ireland (NSAI) Israel (SII) Japan (JISC) Mexico (DGN) Namibia (NSI) Netherlands (NEN) Norway (SN) Portugal (IPQ) Serbia (ISS) Slovenia (SIST) Sweden (SIS) Switzerland (SNV) Thailand (TISI) Tunisia (INNORPI) Uruguay (UNIT) Zimbabwe (SAZ)

Answers to Q.2: "Which services cause the greatest loss and/or harm for consumers in your country?"

30 x	The services that cause the greatest loss/harm are (please comment):	Argentina (IRAM) Australia (SA) Bahrain (BSMD) Barbados (BNSI) Botswana (BOBS) Canada (SCC) Chile (INN) China (SAC) Colombia (ICONTEC) Czech Republic (UNMZ) Finland (SFS) Germany (DIN) Ghana (GSA) India (BIS) Indonesia (BSN) Iran, Islamic Republic of (ISIRI) Jamaica (BSJ) Kenya (KEBS) Malawi (MBS) Malaysia (DSM) Malta (MCCAA) Panama (COPANIT) Saudi Arabia (SASO) Singapore (SPRING SG) South Africa (SABS) Trinidad and Tobago (TTBS) Turkey (TSE)
------	--	--

		United Arab Emirates (ESMA) United Kingdom (BSI) United States (ANSI)
0 x	Not applicable	
25 x	No information	Austria (ASI) Brazil (ABNT) Costa Rica (INTECO) Denmark (DS) Egypt (EOS) Ireland (NSAI) Israel (SII) Japan (JISC) Mauritius (MSB) Mexico (DGN) Namibia (NSI) Netherlands (NEN) Norway (SN) Pakistan (PSQCA) Peru (INACAL) Portugal (IPQ) Serbia (ISS) Slovenia (SIST) Spain (AENOR) Sweden (SIS) Switzerland (SNV) Thailand (TISI) Tunisia (INNORPI) Uruguay (UNIT) Zimbabwe (SAZ)

Answers to Q.3: "What national standards exist for services that you feel might be relevant and useful internationally (e.g. cross-border issues)?"

20 x	Existing national standards are (please comment):	Argentina (IRAM) Australia (SA) Botswana (BOBS) Canada (SCC) China (SAC) Colombia (ICONTEC) Costa Rica (INTECO) Denmark (DS) Egypt (EOS) Germany (DIN) India (BIS) Indonesia (BSN) Jamaica (BSJ) Kenya (KEBS) Malawi (MBS) Spain (AENOR) Turkey (TSE) United Arab Emirates (ESMA) United Kingdom (BSI) United States (ANSI)
11 x	Not applicable	Bahrain (BSMD) Czech Republic (UNMZ)

		Finland (SFS) Ghana (GSA) Iran, Islamic Republic of (ISIRI) Malaysia (DSM) Malta (MCCAA) Namibia (NSI) Pakistan (PSQCA) Peru (INACAL) Uruguay (UNIT)
24 x	No information	Austria (ASI) Barbados (BNSI) Brazil (ABNT) Chile (INN) Ireland (NSAI) Israel (SII) Japan (JISC) Mauritius (MSB) Mexico (DGN) Netherlands (NEN) Norway (SN) Panama (COPANIT) Portugal (IPQ) Saudi Arabia (SASO) Serbia (ISS) Singapore (SPRING SG) Slovenia (SIST) South Africa (SABS) Sweden (SIS) Switzerland (SNV) Thailand (TISI) Trinidad and Tobago (TTBS) Tunisia (INNORPI) Zimbabwe (SAZ)

Answers to Q.4: "What other services do you consider to be a priority for international standardization?"

22 x	Other priority services are (please comment):	Australia (SA) Botswana (BOBS) Canada (SCC) Chile (INN) China (SAC) Colombia (ICONTEC) Czech Republic (UNMZ) Egypt (EOS) Germany (DIN) India (BIS) Indonesia (BSN) Iran, Islamic Republic of (ISIRI) Kenya (KEBS) Malawi (MBS) Malaysia (DSM) Mauritius (MSB) Peru (INACAL) Saudi Arabia (SASO) Singapore (SPRING SG)
------	---	---

		Turkey (TSE) United Kingdom (BSI) United States (ANSI)
3 x	Not applicable	Argentina (IRAM) Pakistan (PSQCA) Thailand (TISI)
30 x	No information	Austria (ASI) Bahrain (BSMD) Barbados (BNSI) Brazil (ABNT) Costa Rica (INTECO) Denmark (DS) Finland (SFS) Ghana (GSA) Ireland (NSAI) Israel (SII) Jamaica (BSJ) Japan (JISC) Malta (MCCAA) Mexico (DGN) Namibia (NSI) Netherlands (NEN) Norway (SN) Panama (COPANIT) Portugal (IPQ) Serbia (ISS) Slovenia (SIST) South Africa (SABS) Spain (AENOR) Sweden (SIS) Switzerland (SNV) Trinidad and Tobago (TTBS) Tunisia (INNORPI) United Arab Emirates (ESMA) Uruguay (UNIT) Zimbabwe (SAZ)

Answers to Q.5: "What are the key issues for consumers in the provision of a service?"

32 x	The key issues are (please comment):	Argentina (IRAM) Australia (SA) Bahrain (BSMD) Barbados (BNSI) Botswana (BOBS) Canada (SCC) Chile (INN) China (SAC) Costa Rica (INTECO) Czech Republic (UNMZ) Denmark (DS) Finland (SFS) Germany (DIN) Ghana (GSA) India (BIS) Indonesia (BSN)
------	---	---

		Iran, Islamic Republic of (ISIRI) Jamaica (BSJ) Kenya (KEBS) Malawi (MBS) Malaysia (DSM) Malta (MCCAA) Mauritius (MSB) Norway (SN) Peru (INACAL) Saudi Arabia (SASO) Singapore (SPRING SG) South Africa (SABS) Trinidad and Tobago (TTBS) United Arab Emirates (ESMA) United Kingdom (BSI) United States (ANSI)
3 x	Not applicable	Pakistan (PSQCA) Thailand (TISI) Turkey (TSE)
20 x	No information	Austria (ASI) Brazil (ABNT) Colombia (ICONTEC) Egypt (EOS) Ireland (NSAI) Israel (SII) Japan (JISC) Mexico (DGN) Namibia (NSI) Netherlands (NEN) Panama (COPANIT) Portugal (IPQ) Serbia (ISS) Slovenia (SIST) Spain (AENOR) Sweden (SIS) Switzerland (SNV) Tunisia (INNORPI) Uruguay (UNIT) Zimbabwe (SAZ)

Comments from Voters		
Member:	Comment:	Date:
Argentina (IRAM)	Comment	2016-04-20 19:05:22
<p>Cell phones because there is a continuous changing of the models and therefore of the annual subscription with bad information and no control by the user.</p> <p>Cell phones cause a great loss of money for consumers because of the bad information and the charge of several applications or games that are not asked for the user and messages that are out of its control.</p> <p>IRAM 9900 – Buenas prácticas comerciales (Good commercial practices)</p>		

- Information
- Warranties
- Service post sale

Australia (SA)	Comment	2016-04-22 01:02:39
-----------------------	----------------	------------------------

Billing complaints in Telecommunications (including mobile phones, internet) and utilities.

Smart Meters and their potential for assisting consumers manage their power needs. Currently the amount of information a consumer can obtain appears to be largely in the hands of the power suppliers. Perhaps Smart Meters is an area for an international standard or guidance document.

The top 7 by order and in percentage terms of recent conciliations relating to services are:

- Mechanical repairs to a motor vehicle 19.9%
- Travel 13.3%
- Fitness 5.5%
- Body repairs to a motor vehicle 5.2%
- Airlines 4.4%
- Photography 4.1%
- Real Estate 4.1%

Health services can cause a number of complaints; including those related to the “silver economy”.

Existing Australian standards for services cover a range of subject matters such as transportation, telecommunications, finance and insurance, health, tourism and more. They include (but not limited to):

- AS/NZS ISO 10002:2014 Guidelines for complaint management in organizations
- HB 229-2006 The why and how of complaints handling
- AS ISO 10019-2005 Rec:2016 Guidelines for the selection of quality management system consultants and use of their services
- AS ISO 10019-2005 Guidelines for the selection of quality management system consultants and use of their services
- HB 90.2-2000 Rec:2016 The Service Industry Handbook - Guide to ISO 9001:2000
- HB 90.8-2000 Rec:2016 Healthcare Services - Guide to ISO 9001:2000
- AS ISO 10015-2006 Quality management - Guidelines for training (ISO 10015:1999, MOD)
- HB 201-2006 Tutoring code of practice
- HB 251-2004 Customer Satisfaction Measurement - A handbook for users of AS/NZS ISO 9001:2000
- AS 3906-2004 Quality of service - Guide to customer expectations
- AS/NZS 3905.12-1999 Quality system guidelines - Guide to AS/NZS ISO 9001 for architectural and engineering design practices
- AS 3905.15-1998 Quality system guidelines - Guide to AS/NZS ISO 9001:1994 for the accountancy profession
- AS 3905.11-1998 Quality system guidelines - Guide to AS/NZS ISO 9002:1994 for the motor vehicle maintenance and repair industry
- AS 3905.10-1997 Quality system guidelines - Guide to AS/NZS ISO 9001:1994 for the finance industry
- AS 3905.9-1996 Quality system guidelines - Guide to AS/NZS ISO 9001:1994 for telecommunications call charging and call billing
- AS/NZS 3905.3-1994 Quality system guidelines - Guide for the hospitality industry
- AS 4485.1-1997 Security for health care facilities - General requirements
- AS 4485.2-1997 Security for health care facilities - Procedures guide
- AS 5725:2015 Boarding Standard for Australian schools and residences
- AS 2999-1989 - Alarm systems for the elderly and other persons at risk
- AS 4083-2010 - Planning for emergencies - Health care facilities
- AS 4846:2014 - Person and provider identification in healthcare
- AS 4590.2 Information Technology – Interchange of Client Information – XML Implementation – Part 2

- AS 4187-1994 AMDT 2 Code of practice for cleaning, disinfecting and sterilizing reusable medical and surgical instruments and equipment, and maintenance of associated environments in health care facilities
- HB 202-2000 A management system for clinical and related wastes - Guide to application of AS/ NZS 3816-1998, Management of clinical and related wastes
- Collaborative economy
- Vulnerable consumers
- Access to essential services
- Lack of sufficient and understandable information from a consumer viewpoint
- Smart Meters and energy service provision

Choice, transparency, value for money and convenience as well as being safe and treated fairly.

Bahrain (BSMD)	Comment	2016-04-21 06:41:26
moblies and smart phones moblies and smart phones safety and suitability for use		
Barbados (BNSI)	Comment	2016-04-19 09:26:05
Telecommunications Telecommunications High standards. Value for money. Terms and Conditions prior to the contract. Ability to contact service provider easily when something goes wrong without having to make several attempts. Lack of good customer service.		
Botswana (BOBS)	Comment	2016-04-19 12:24:02
<ol style="list-style-type: none"> Hire purchase and credit providers, banks and insurance companies - consumers not understanding their contracts Imported vehicles and second hand cars - no guarantees and warranties, poor mechandability, no defect notices Mobile network providers - poor internet network connectivity, dysfunction handsets, no warranty on handsets Public Utilities - poor response to complaints and disputes, late and high utility bills Retail - tainted food products, poor verification of cooking gas and fuels Accommodation and real estate - landlord and tenant disputes, unscrupulous sales of plots and residential properties Service provision - poor response to complaints and disputes between constructors and clients, spoilage of clothes during laundry and dry clean services <ol style="list-style-type: none"> Imported vehicles and second hand car dealing Hire Purchase and credit provision Mobile Network provision <ol style="list-style-type: none"> BOS 57:2009 - The testing of motor vehicles for roadworthiness - code of practice BOS 9: 2014 Pre-packed goods for the ultimate consumer: Labelling, presentation and advertising: General requirements BOS ISO 10002:2004 Quality Management - Customer satisfaction - Guidelines for complaint handling in organizations <ol style="list-style-type: none"> recognizing and addressing challenges that hamper consumer representation in standard development 		

	<ol style="list-style-type: none"> 1. Consumer rights; the right to be informed and be heard; the right to choice and redress, the right to consumer education and the right to safety and healthy environments 2. Price, reliability of supply, return policy, warranty conditions and truthfulness 	
Brazil (ABNT)	Comment	2016-04-20 18:53:27
<p>we abstain</p> <p>we abstain</p> <p>we abstain</p> <p>we abstain</p> <p>we abstain</p>		
Canada (SCC)	Comment	2016-04-21 19:07:02
<ol style="list-style-type: none"> a. Telecommunication/Mobile phone issues (6) b. Health/Home Care Services (3) c. Home renovations/repairs (4) d. Consumer debt services (2) a. Tourism Service Standards (hotel and travel issues) (2) b. Health/Home Care Service Standards (3) c. Home renovation/contractors (3) a. Water Service Standards (2) b. Tourism Service Standards (2 – but we don't participate on the Tourism ISO committee) a. Health care response and process time (2) b. Shared services/collaborative economy (4) a. Clear and easily obtained info (3) b. The right to be heard and obtain a resolution (2) c. Privacy (2) d. Complaint handling (2) 		
Chile (INN)	Comment	2016-04-21 19:19:38
<p>Te services cause the most complaints for consumer in Chile are:</p> <ul style="list-style-type: none"> - Massive events (concerts; sporting events) - Telecommunications services; - Financial services; - Medical care centers; - Retail; - Parking services (private parking). <p>The services cause the greatest loss and harm for consumer en Chile are:</p> <ul style="list-style-type: none"> - Electricity, water and gas supplies; 		

- Massive events (when cancelled/or when there is insufficient safety measures);
- Repair centers.

See answer to question 1.

We believes that the key issues for consumer in the provision of a service are:

- Consumer understanding of the service conditions;
- Consumer understanding of safety measures associated with the services, if required;
- Consumer undstanding of after- sales services.

China (SAC)	<i>Comment</i>	2016-04-20 03:23:38
--------------------	-----------------------	------------------------

E-commerce shopping services, mobile services, commercial internet services, tourist services, express services, beauty treatment and hair designing services, and maintenance and repair services.

E-commerce shopping services, tourist services, express services, housing intermediary service, beauty treatment services, auto repair services.

Some Chinese national standards in the areas of tourist services, express services, e-commerce shopping services, learning services and the services for the aged might be useful internationally.

Express services, cross-border e-commerce services, transportation services, tourist services and the services for the aged.

The key issues for consumers in the provision of a service include service safety, information transparency, time limit, service quality, quantitative indicators, service procedures, and service evaluation.

Colombia (ICONTEC)	<i>Comment</i>	2016-04-20 18:36:39
---------------------------	-----------------------	------------------------

Services that cause the most complaints for consumers in Colombia are: Health, Electricity Supply, Water and Sanitation, Restaurants, tourism, cell phone, Postal and#Financial.

#

Services that cause the greatest loss and or harm for consumers in Colombia: Health, Electricity Supply, Water and Sanitation, cell phone, tourism and restaurants.

NTC 6072 CENTER FOR DELIVERY OF TRAINING AND EDUCATION FOR PROTECTION AGAINST FALLS AT HEIGHTS. REQUIREMENTS

END 071 PUBLIC SERVICE EMPLOYMENT. REQUIREMENTS FOR PROVISION OF JOB MANAGEMENT AND PLACEMENT SERVICES

NTC 5840 FUNERAL SERVICES. REQUIREMENTS

NTC 5906 ARBITRATION AND/OR MEDIATION CENTER. GENERAL REQUIREMENTS FOR SERVICE

NTC 5520-1 SERVICE QUALITY FOR SMALL RETAIL TRADE. PART 1.GENERAL REQUIREMENTS.

END 75 EDUCATION AND TRAINING CENTERS FOR SAFETY AND HEALTH IN OPENCAST MINING.

END 76 EDUCATION AND TRAINING CENTERS FOR SAFETY AND HEALTH IN UNDERGROUND MINING.

NTC 5520-2 SERVICE QUALITY FOR SMALL RETAIL TRADE. PART 2. FISH MARKETS REQUIREMENTS.

NTC 5520-3 SERVICE QUALITY FOR SMALL RETAIL TRADE.PART 5.REQUIREMENTS FOR FLOWER SHOPS.

NTC 5520-4 SERVICE QUALITY FOR SMALL RETAIL TRADE. PART 4. REQUIREMENTS FOR BUTCHERS AND DELICATESSEN SHOPS

NTC 6129 CLEANING AND DECONTAMINATION OF MEDICAL DEVICES AND PRODUCTS FOR HOSPITAL USE. INTEGRATED MANAGEMENT OF MEDICAL DEVICES IN CLEANING AND DECONTAMINATION AREA.

RECONSTRUCTION AND PARCIAL#REPAIR OF DISTRIBUTION TRANSFORMERS. GENERAL REQUIREMENTS FOR SERVICE.

#

Costa Rica (INTECO)	Comment	2016-04-22 22:03:57
INTE 01-02-01 Standard for quality service delivering. Requirements. Quality, time, customer service....		
Czech Republic (UNMZ)	Comment	2016-04-21 08:18:28
financial services, public services (elektricity, gas) and ITC services ITC services services in transport price, quality, clear specification of the service, reliability and fair behaviour of the provider of the service		
Denmark (DS)	Comment	2016-04-20 15:11:01
Banking, internet, mobile telephony, TV subscriptions, fixed telephony, real estate, life insurance INSTA 800 (Nordic standard for Cleaning Quality) Quality and Service in the Tourist Industry (national Guidance Standard on its way) Matching of expectations Transparency Ability to evaluate quality versus price		
Egypt (EOS)	Comment	2016-04-06 13:48:04
We do not have statistics in this field. We do not have statistics in this field. 1- ES 4637/2013 Warranty certificate 2- ES 4693/2008 Instructions for use of products of consumer interest. 3-ES 4841/2014 Advertising require meats of (Products and services) . 4- ES 6624/2008 The invoice. 5-ES 7183/2011 Service , repair , and maintenace centers		

Curative health		
Finland (SFS)	Comment	2016-04-18 14:25:44
<p>Housing renovations, Housing rentals, Car repairs, Internet subscriptions, Insurance.</p> <p>Cross-border: Travel by air, subscription traps.</p> <p>Travel, cars (sales, service, repair), Housing (sales, construction and renovation, rentals).</p> <p>Cross-border: Travel by air.</p> <p>timeliness, quality, clear contract terms, identifying the service provider, adequate redress mechanisms.</p>		
Germany (DIN)	Comment	2016-04-21 15:58:17
<p>Financial services, health services, travel and transport, postal services, rental services</p> <p>Financial services, health services, travel and transport services</p> <p>DIN SPEC 77003 Personal and Household Services - Information, Advice and Placement</p> <p>Specifications on financial analysis for consumers:</p> <p>DIN SPEC 77222 Standardized financial analysis for private households</p> <p>DIN SPEC 77223 Standardized asset analysis and risk analysis for private investors</p> <p>European standards regarding health services (under development):</p> <p>prEN 16372 Aesthetic surgery and aesthetic non-surgical medical services</p> <p>prEN 16844 Aesthetic medicine services - Non-surgical medical procedures</p> <p>Every service that is similarly defined and regulated in most countries and that will be delivered cross-border</p> <p>Transparency/Information; Safety and Health Aspects; Aspects of inclusive Design;</p> <p>Data Security and Data Protection, Quality of service; Customer Service and Customer Satisfaction</p>		
Ghana (GSA)	Comment	2016-04-11 11:58:09
<p>Telecommunication, Banking and Food Retail</p> <p>Food Retail</p> <p>Security and Quality of Service</p>		
India (BIS)	Comment	2016-04-22 08:21:37
<p>Real Estate, Tele-communication, Financial services, Cyber/ISP services</p> <p>Real Estate, Tele-communication, Financial services, Cyber/ISP services</p> <p>Bureau of Indian Standards, being a member of ISO COPOLCO, has adopted the following Standards:</p>		
IS/ISO/IEC Guide 14	Purchase Information Of Goods And Services Intended For Consumers	

IS/ISO/IEC GUIDE 37	Instructions For Use Of Products Of Consumer Interest
IS/ISO/IEC GUIDE 41	Packaging - Recommendations for addressing consumer needs
IS/ISO/IEC GUIDE 46	Comparative Testing Of Consumer Products And Related Services - General Principles
IS/ISO/IEC GUIDE 74	Graphical symbols - Technical guidelines for the consideration of consumers' Needs
IS/ISO/IEC GUIDE 76	Development of service standards - Recommendations for addressing consumer issues

Banking Services

Standards implementation issues which are required to be improved.

Indonesia (BSN)	Comment	2016-04-22 09:26:04
------------------------	----------------	------------------------

A. Based on the data of Consumer NGO (2013-2015), 5 most complaints are :

1. Banking services 17.1%
2. Property 15.5 %
- 3, Telecommunication 8.1 % (IT services)
4. On line trading 7.5 %
5. Leasing 6.5 %

Other

6. Public transport service
7. Automotive workshop service
8. Professional services (legal and medical)

B. Based on the data of Financial Services Authority (2013-2015), 5 most complaints are ;

1. Banking services 60.5 %
2. Non Banking Financial services 35.8 %
3. Bank and non bank credit 34 %
4. Collateral Loans 25%
5. Credit restructuring 20%

IT services : internet, cellular phone billing

No Standard

On line trading services or IT Services

1. Minimum Services Requirements
2. Tariff Billing Calculation
3. After sales services requirements for certain services
4. Proper complaint handling and the procedure
5. Consumer Dispute Settlement (Institution, system, experts)
6. unfair contract term
7. Consumer data privacy

Iran, Islamic Republic of (ISIRI)	Comment	2016-04-22 20:46:23
--	----------------	------------------------

long time services,less quality services

The services with low quality design ,

safety, quality,price,guaranty&warranty		
Jamaica (BSJ)	Comment	2016-04-21 16:36:59
<p>Communication technologies; Utilities; Sales and refund policies; Queing time in Banks and other financial institutions; Tax administration; Tatooning; Public procurement; Housing and rental services; Tranpsort and taxi services.</p> <p>Financial service charges and dollar devaluation; Utilities; Credit cards; Transport and road infrastructure; Medical services</p> <p>JS 321: 2013 - Jamaican Standard Guide for Public behaviour.</p> <p>General customer service and documentation; especially for SMEs.</p>		
Kenya (KEBS)	Comment	2016-04-19 13:46:15
<p>1. Cross border services</p> <p>2. Testing services and testing turn-around times</p> <p>3. Multiple sampling requirements</p> <p>4. Corruption/Bribery</p> <p>1. Importation of sub-standard goods and products</p> <p>2. Incomplete testing of products i.e., testing some parameters and leaving out some</p> <p>3. Multiple sampling of goods and products at points of entry</p> <p>4. Enlarged bureaucracy at border points</p> <p>5. Environmental degradation</p> <p>KS 1515 on used motor vehicles - inspection</p> <p>Financial Management - Indicators for good banking management</p> <p>University Education</p> <p>Respect for ones culture, transparency, opennesss and honesty.</p>		
Malawi (MBS)	Comment	2016-04-19 17:44:14
<p>1. Banking services</p> <p>2. Mobile phone services</p> <p>3. Health services</p> <p>4. Catering services</p> <p>1. Health services</p> <p>Adopted ISO 9001 Standard</p> <p>1. Banking services</p> <p>2. Mobile phone services</p> <p>3. Health services</p> <p>4. Catering services</p> <p>1. Speed (efficiency) e.g long cues</p>		

Malaysia (DSM)	Comment	2016-04-20 09:55:36
<p>According to Malaysia National Consumer Complaint Centre, Services generating the most complaints are Online shopping services, telecommunications, travel and leisure</p> <p>according to Malaysia National Consumer Complaint Centre, Services generating the most complaints are Online shopping services, telecommunications, travel and leisure, housing and real estates, and banking/ finance</p> <p>Other priority services are as service provider uses mobile application and internet as a mean to promote and gain profits. (taxi/ cab services/ hotel/ cleaning/ autos, machine repair services provider which provide service on internet or mobile apps)</p> <p>The key issues are the level of confidence/ reputation that promoted by the service provider such as rating genuinity, and how quality of services can be displayed in an intangible forms. Also how rate of services can be judge, what is the scale of judging the service? Price, safety of goods and services, the rights against supplier & manufacturer in connection with any of the guarantees & warranties implied by the act/law.</p>		
Malaysia (DSM)	Comment File	2016-04-20 09:55:36
CommentFiles/COPOLCO N195_DSM.docx		
Malta (MCCAA)	Comment	2016-04-21 07:07:24
<p>Telecommunications Services</p> <p>Telecommunications Services</p> <p><i>Provision of unrequested services (with the pretext to offering a new contract to a subscriber) and considering the subscribers' failure to opt out as consent to a new contract – inertia selling, billing, provision of service (for example downloads/uploads not as per contract), switching, termination of contract (in particular in telecom services the service provider can change contract terms when giving 30 day notice whilst consumers do not have that right)</i></p>		
Mauritius (MSB)	Comment	2016-04-21 14:17:32
<p>Public transportation</p> <p>Healthcare services - Patients have to wait for long hours to see a doctor/ have necessary treatment</p> <p>Quality of service</p> <p>Excellent customer service</p> <p>Response to complaints</p>		
Norway (SN)	Comment	2016-04-07 17:10:57
<p>The following consumer issues are relevant:</p> <ul style="list-style-type: none"> - Information about the service (including terms and conditions, price etc.) - contact information (how to get in contact with the customer service centre, service provider) - competent and agreeable customer services including adequate and transparent procedures for complaints handling and redress 		
Panama (COPANIT)	Comment	2016-04-21 21:17:21

Pay Cable TV		
Communication (celular contract)		
Peru (INACAL)	Comment	2016-04-21 18:37:05
<p>The services that generate the most amount of complaints are banking, finance and telecommunications. Regarding the first two points of incidence, credit cards and consumer loans are the ones that generate the most. In the telecommunications sector the incidence of complaints is oriented to billing and service quality</p> <p>There are no national technical standards for services different to the adopted from the ISO standards, but we would like to mention the existence of the provisions of Book Claims contained in Law 29571 Protection Code and Consumer Protection and its regulations; which helps the consumer to file your claim or nonconformity with the contracted services or goods, making it an obligation for the provider to give a response within a specified period</p> <p>Other priority services are the ones related to e-commerce and cross-border trade.</p> <p>The key issues are information, quality and safety.</p>		
Saudi Arabia (SASO)	Comment	2016-04-21 13:19:34
<ul style="list-style-type: none"> • Education • Transportation • Health Care • Companies services • Tourism <p>Health care</p> <p>Religious tourism</p> <ul style="list-style-type: none"> • Quality services • Time • Deal with consumers • Meet consumers requiremnts • 		
Singapore (SPRING SG)	Comment	2016-04-15 02:59:23
<p>1) Beauty services</p> <p>2) Contractors</p> <p>3) Travel</p> <p>4) Telecommunications</p> <p>1) Beauty Services</p> <p>2) Contractors</p> <p>3) Travel</p> <p>4) Telecommunications</p> <p>1) Finance</p> <p>2) Tourism</p>		

1) Sales Tactics		
2) Failure to honour contracts		
3) Misrepresentation of services		
South Africa (SABS)	Comment	2016-04-21 08:39:45
Cellphone and mobile data services		
Financial services		
Proper disclosure and information		
Fair and reasonable terms and conditions		
Quick and responsive disputes resolution		
Spain (AENOR)	Comment	2016-04-22 12:53:16
<p>According to one of the main consumers organizations in Spain, the sectors that in 2015 got more registered complaints from consumers in Spain were, in this order: telecommunications, automobile industry (very much linked to the Volkswagen case), the banking sector and the energy supply.</p> <p>AENOR has about 30 national standards (of 6 different sectors of activity) dealing with services specifically for consumers. Not all of them are service standards strictly speaking, in the sense that they do not describe how the service is provided but certainly are useful tools to increase or guarantee the quality of the service provision. The vast majority of them are relevant for the national market as they are services provided within national boundaries and do not cover cross-border issues.</p> <p>We have with two groups of national standards that truly respond to the complete profile requested in the survey (national service standard for consumers tackling cross-border issues, for example).</p> <p>They are the UNE standards on the provision of tourism services and more specifically for accommodation and restaurants, areas in which ISO/TC 228 "Tourism and related services" is not ready to work on yet.</p> <p>And a set of standards on retail trade for which I provide the codes and titles here below. These are a guarantee of service for residents but also for visitors and tourists though these guarantees will not be the same as in their countries unless they become international:</p> <ul style="list-style-type: none"> • UNE 175001:2013 Service quality for small retail trade. Part 1: General requirements • UNE 175001-2:2004 Service quality for small retail trade. Part 2: Requirements for fishmonger's • UNE 175001-3:2005 Service quality for small retail trade. Part 3: Requirements for optician's • UNE 175001-4:2005 Service quality for small retail trade. Part 4: Requirements for butcher's and • UNE 175001-5:2005 Service quality for small retail trade. Part 5: Requirements for flower shops • UNE 175001-6:2015 Service quality for small retail trade. Part 6: Requirements for service stations 		
Trinidad and Tobago (TTBS)	Comment	2016-04-20 21:52:17
Government Public Services, in the area of renewals of permits, licenses, travel documents health care etc.		
Health Care services.		
Quality and timely delivery of service.		
Turkey (TSE)	Comment	2016-04-22 14:53:35
Banking services, Telecommunication services, E-commerce services:		
Banking services:		

Credit card annual fees, high interest rate on installments, high interest rate on mortgages and consumer loans, high transaction costs on money transfer and EFT ([Electronic Funds Transfer](#))

Telecommunication services:

- Government administrators impose too many taxes and deductions on the consumer phone bills
- Service Providers on the market place bewilder the consumers by not providing explicit and suitable packages.
- Services are provided overpriced.

E-commerce services:

- As sufficient supervision and audits have not been made by the professional organizations in this field, widespread frauds have been occurring on a daily basis
- It's not enough for Service Providers and Vendors to be compatible with the monitoring and control mechanisms in line with the international standards; monitoring should be implemented and sustained.

Utility Services (Electricity, gas, water services):

Electric Utility Service:

Utility companies have been charging the consumers with unrelated charges (Retail Sales Service Fee, Turkish Radio and Television share Tax, Energy Funds, Municipal Consumption Tax, Transmission & Distribution losses fee, etc.) In accordance with the principle of transparency and EU standards, instead of detaching the said charges from the consumer bills, utility companies combined all these and other alike unfair charges under one name and column and hide the details of the fee being deducted and continue to wrongfully charge the consumer.

If the consumer pays the electricity bill late even for once, utility company does not actually cut the power but interrupt the service on paper and unjustly charge the consumer for power on-off fee.

Some distribution companies cut the power of a consumer, who owns multiple utility accounts due to a debt arising from one of his/her accounts and without the payment of that debt, the consumer cannot receive electric service in any other non-residential or business and as a result of this the consumer is exposed to major damage.

There are frequent power outages. As a result of these sudden power outages, many electronic devices get damaged or destroyed; this causes significant job losses.

But consumers do not only suffer from the property damage; but also, suffer from non-pecuniary damage because of the often and sudden disruption of power outages experienced affects the consumers' psychology.

Gas Utility Service:

Consumers are forced to pay high-priced values for the gas they use; even when the price of imported gas fell, gas companies do not reflect that on the bill and consumer is still being charged overpriced. Consumers also have to pay costly security deposit fees.

Municipal Water Services:

Consumers are being charged unreasonable additional charges and pay expensive fees to get water service.

There have been appropriate changes made in the paperwork as far as the warranty certificates, user guides and manuals, after-sales services, prepaid home sales, distance sales contracts, the price tag of standardization, hire-purchase contracts, subscription agreements, mortgage / loan contracts, etc. to be comparable with the EU standards and these and alike modifications are still being worked on.

EU Consumer Law and legislation harmonization efforts to be noted and legislative changes are being made. However, the main problem is there isn't any necessary and sufficient market surveillance to ensure the viability of these changes made; instead of encouraging the consumer organizations to play a more active role in these areas, they are being left to be ineffective and even without initiative

Our priority is to form a network of essential communication and coordination channel/s between the Consumers, Consumer organizations, and the Public Administrators (legislation on the consumer law enforcement); the adoption of such governance (mutual management) and implementation of this approach will enable it. As a result, can help out with eliminating the weak consumer organizations and ensuring the institutionalization; to develop standards to be able to provide the Right to Representation services in Consumer supreme courts/councils is also our main concern.

Prevention of consumer rights violations and having conscious consumers is dependent on the Consumer Organizations' strength and effectiveness. For this purpose, government authorities and agencies should adopt the concept of synergy and be a partner in these matters.

Neither related governmental agencies nor municipal departments take active role and do what is necessary to educate, train, inform, and protect the consumer; these agencies and departments do not pay enough attention to the consumer organizations and further, make it harder for these organizations to help out consumers get support and protection.

the comments that we are trying to add here as answer 5, it is not accepted by the system so we pasted all the comments including this one #into the comments template. I hope this time the system accepts it.

Turkey (TSE)	Comment File	2016-04-22 14:53:35
---------------------	---------------------	------------------------

[CommentFiles/COPOLCO N195_TSE.doc](#)

United Arab Emirates (ESMA)	Comment	2016-04-19 14:55:06
------------------------------------	----------------	------------------------

Services that depends on the competencies, skills and capabilities of the individuals for the delivery of the service.

Installation services that are related to Electrical appliances that poor installation of maintainance could lead into a damage of property or other losses.

UAE through National Qualification Authority is developing occupational standards that address the capabilities, competencies and skills of individuals who deliver the services.

Consumers need to be aware that they need to seek services from competent individuals.

United Kingdom (BSI)	Comment	2016-04-21 12:30:42
-----------------------------	----------------	------------------------

Banking/Financial services

Energy/Utility companies

Telecoms/Mobile phone companies

The top three services that cause the greatest loss/harm are as follows (stats from Citizens Advice Scotland, England & Wales - some clients referred on to Trading Standards):

1. Debt/Financial services - clearly the highest number of queries and requests for help (Financial capability, Pensions, Catalogue and mail order, Unsecured personal loan, Credit, store & charge card, Bank & building society overdrafts)
2. Energy services (gas, electricity, water); smaller number re other utilities: phones and broadband
3. Property services (Owner occupier, Local authority rent arrears, Private rented sector, Building repairs and improvements)

BS 18477:2010 Inclusive service provision. Requirements for identifying and responding to consumer vulnerability

BS 8477:2014 Code of practice for customer service

Web Accessibility		
Adventurous activities		
<ul style="list-style-type: none"> • Customer contact • Understanding customer requirements • Service planning and delivery • Accessibility • Quality management/monitoring • Resources & Technology • People • Customer information • Billing • Complaints handling & redress • Feedback, innovation and improvement 		
United States (ANSI)	Comment	2016-04-20 19:15:31
<p>-process are too complicated, confusing and cumbersome; i.e. it takes too long to get what you are requesting</p> <p>-people are not empathetic or caring to the customers' needs</p> <p>-government processes (permits/fees) cost too much to comply (from a business as a customer perspective)</p> <p>I can think of no local government services that cause loss or harm to consumers of those services, but it is possible that incorrect provision of these services (accuracy) could cause problems, e.g. incorrect inspections of potential hazardous or dangerous situations, etc.</p> <p>Customer Service Standards are three-fold.</p> <p>1- Accuracy of information; e.g. if you ask multiple people in the same agency the same question, you should get the same answer).</p> <p>2- Promptness of service delivery; e.g. processes should be streamlined so cycle times drop, commensurate with number of steps in a process, etc.</p> <p>3- Professionalism of staff; e.g. ability to provide courteous, empathetic services to individuals</p> <p>Food labeling/Food production both animal husbandry and sourcing, and produce.</p> <p>1- Accuracy of information; e.g. if you ask multiple people in the same agency the same question, you should get the same answer).</p> <p>2- Promptness of service delivery; e.g. processes should be streamlined so cycle times drop, commensurate with number of steps in a process, etc.</p> <p>3- Professionalism of staff; e.g. ability to provide courteous, empathetic services to individuals</p>		

Comments from Commenters		
Member:	Comment:	Date:
Armenia (SARM)	Comment File	2016-04-22 17:05:04
CommentFiles/COPOLCO N195_SARM.docx		
Saint Lucia (SLBS)	Comment	2016-04-21 21:16:34
Comment file attached		
Saint Lucia (SLBS)	Comment File	2016-04-21 21:16:34

Viet Nam (STAMEQ)	Comment	2016-04-13 04:38:51
	<ol style="list-style-type: none">1. Services generating the most complaints: product and commodity supply services2. The services that cause the greatest loss/harm: sale services3. Not applicable4. Other priority services: online sale services5. The key issues are:<ul style="list-style-type: none">- product safety;- corresponding between price and quality;- information of product shall be correct.	

AGENDA ITEM 9 CONSUMER PRIORITIES IN STANDARDIZATION ON SERVICES

SARM (Armenia) comments on the Survey of ISO/COPOLCO WG 18 “Consumer issues in standardization of services”

1.	Which services cause the most complaints for consumers in your country?	<p>Services generating the most complaints are (please comment):*</p> <ol style="list-style-type: none"> 1. Electricity supply - Frequent unplanned electricity outages that cause malfunctions of electrical devices. 2. Improper warranty services for sold goods, e.g. electrical appliances 3. Drinking water supply services 4. Public transportation services 5. Public food services <p>Not applicable No information</p>
2.	Which services cause the greatest loss and/or harm for consumers in your country?	<p>The services that cause the greatest loss/harm are (please comment):*</p> <p>The consumers mostly complain about high prices and bad services in electricity and water supply sectors.</p> <p>Not applicable No information</p>
3.	What national standards exist for services that you feel might be relevant and useful internationally (e.g. cross-border issues)?	<p>Existing national standards are (please comment):*</p> <p><u>Not applicable</u></p> <p>No information</p>
4.	What other services do you consider to be a priority for international standardization?	<p>Other priority services are (please comment):*</p> <p>Among various other types of services, we consider that services for passengers in airports, railway stations and/or bus terminals could be priority sectors for international standardization.</p> <p>Not applicable No information</p>
5.	What are the key issues for consumers in the provision of a service?	<p>The key issues are (please comment):*</p> <p>Issues related to the compensation to client for damage caused from improper quality of services</p> <ol style="list-style-type: none"> 1. Issues related to concluding fair contracts with clients on public utilities services 2. Hidden effects from the provided services <p>Not applicable No information</p>
(*) A Comment is required for this answer value.		

SLBS (Saint Lucia) comments on the Survey of ISO/COPOLCO WG 18 “Consumer issues in standardization of services”

Date:	Document:	Project:
-------	------------------	----------

MB/NC ¹	Line number (e.g. 17)	Clause/ Subclause (e.g. 3.1)	Paragraph/ Figure/ Table/ (e.g. Table 1)	Type of comment ²	Comments	Proposed change	Observations of the secretariat
LC			1		Which services cause the most complaints for consumers in your country?	Services generating the most complaints are <ul style="list-style-type: none"> • Sanitation/Water supply • Garbage collection • Road works • Telecommunications • Healthcare • Education service • Financial/Banking • Transportation 	
LC			2		Which services cause the greatest loss and/or harm for consumers in your country?	<ul style="list-style-type: none"> • Health care provision 	
LC			3		What national standards exist for services that you feel might be relevant and useful internationally (e.g. cross-border issues)?	Not applicable	
LC			4		What other services do you consider to be a priority for international standardization?	<ul style="list-style-type: none"> • Recycling of plastics & wood products; • Health care provision standards 	
LC			5		What are the key issues for consumers in the provision of a service?	<ul style="list-style-type: none"> • Service quality and delivery • Time taken for delivery • Costs • Consumer education • Consumer redress 	

¹ **MB** = Member body / **NC** = National Committee (enter the ISO 3166 two-letter country code, e.g. CN for China; comments from the ISO/CS editing unit are identified by **)

² **Type of comment:** **ge** = general **te** = technical **ed** = editorial

TSE (Turkey) comments on the Survey of ISO/COPOLCO WG 18 “Consumer issues in standardization of services”

Date:	Document:	Project:
-------	-----------	----------

MB/NC ¹	Line number (e.g. 17)	Clause/ Subclause (e.g. 3.1)	Paragraph/ Figure/ Table/ (e.g. Table 1)	Type of comment ²	Comments	Proposed change	Observations of the secretariat
TR					<p>1-Which services cause the most complaints</p> <p>Banking services, Telecommunication services, E-commerce services</p> <p>Banking services: Credit card annual fees, high interest rate on installments, high interest rate on mortgages and consumer loans, high transaction costs on money transfer and EFT (Electronic Funds Transfer)</p> <p>Telecommunication services:</p> <ul style="list-style-type: none"> • Government administrators impose too many taxes and deductions on the consumer phone bills • Service Providers on the market place bewilder the consumers by not providing explicit and suitable packages. • Services are provided overpriced. <p>E-commerce services:</p> <ul style="list-style-type: none"> • As sufficient supervision and audits have not been made by the professional organizations in this field, widespread frauds has been occurring on a daily basis • It's not enough for Service Providers and Vendors to be compatible with 		

1 **MB** = Member body / **NC** = National Committee (enter the ISO 3166 two-letter country code, e.g. CN for China; comments from the ISO/CS editing unit are identified by **)

2 **Type of comment:** **ge** = general **te** = technical **ed** = editorial

TSE (Turkey) comments on the Survey of ISO/COPOLCO WG 18 “Consumer issues in standardization of services”

Date:	Document:	Project:
-------	-----------	----------

MB/NC ¹	Line number (e.g. 17)	Clause/ Subclause (e.g. 3.1)	Paragraph/ Figure/ Table/ (e.g. Table 1)	Type of comment ²	Comments	Proposed change	Observations of the secretariat
					<p>the monitoring and control mechanisms in line with the international standards; monitoring should be implemented and sustained.</p> <p>2-Which services cause the greatest loss and</p> <p>Utility Services (Electricity, gas, water services) Electric Utility Service: Utility companies have been charging the consumers with unrelated charges (Retail Sales Service Fee, Turkish Radio and Television share Tax, Energy Funds, Municipal Consumption Tax, Transmission & Distribution losses fee, etc.) In accordance with the principle of transparency and EU standards, instead of detaching the said charges from the consumer bills, utility companies combined all these and other alike unfair charges under one name and column and hide the details of the fee being deducted and continue to wrongfully charge the consumer.</p> <p>If the consumer pays the electricity bill late even for once, utility company does not actually cut the power but interrupt the</p>		

1 **MB** = Member body / **NC** = National Committee (enter the ISO 3166 two-letter country code, e.g. CN for China; comments from the ISO/CS editing unit are identified by **)

2 **Type of comment:** **ge** = general **te** = technical **ed** = editorial

TSE (Turkey) comments on the Survey of ISO/COPOLCO WG 18 “Consumer issues in standardization of services”

Date:	Document:	Project:
-------	-----------	----------

MB/NC ¹	Line number (e.g. 17)	Clause/ Subclause (e.g. 3.1)	Paragraph/ Figure/ Table/ (e.g. Table 1)	Type of comment ²	Comments	Proposed change	Observations of the secretariat
					<p>service on paper and unjustly charge the consumer for power on-off fee.</p> <p>Some distribution companies cut the power of a consumer, who owns multiple utility accounts due to a debt arising from one of his/her accounts and without the payment of that debt, the consumer cannot receive electric service in any other non-residential or business and as a result of this the consumer is exposed to major damage.</p> <p>There are frequent power outages. As a result of these sudden power outages, many electronic devices get damaged or destroyed; this causes significant job losses. But consumers do not only suffer from the property damage; but also, suffer from non-pecuniary damage because of the often and sudden disruption of power outages experienced affects the consumers' psychology.</p> <p>Gas Utility Service: Consumers are forced to pay high-priced values for the gas they use; even when the price of imported gas fell, gas companies do not reflect that on the bill and consumer is still being charged overpriced. Consumers</p>		

1 **MB** = Member body / **NC** = National Committee (enter the ISO 3166 two-letter country code, e.g. CN for China; comments from the ISO/CS editing unit are identified by **)

2 **Type of comment:** **ge** = general **te** = technical **ed** = editorial

TSE (Turkey) comments on the Survey of ISO/COPOLCO WG 18 “Consumer issues in standardization of services”

Date:	Document:	Project:
-------	-----------	----------

MB/NC ¹	Line number (e.g. 17)	Clause/ Subclause (e.g. 3.1)	Paragraph/ Figure/ Table/ (e.g. Table 1)	Type of comment ²	Comments	Proposed change	Observations of the secretariat
					<p>also have to pay costly security deposit fees.</p> <p>Municipal Water Services: Consumers are being charged unreasonable additional charges and pay expensive fees to get water service.</p> <p>3-What national standards exist for services that you feel might be relevant and useful internationally (e.g. cross-border issues)?</p> <p>Existing national standards are: There have been appropriate changes made in the paperwork as far as the warranty certificates, user guides and manuals, after-sales services, prepaid home sales, distance sales contracts, the price tag of standardization, hire-purchase contracts, subscription agreements, mortgage / loan contracts, etc. to be comparable with the EU standards and these and alike modifications are still being worked on.</p> <p>EU Consumer Law and legislation harmonization efforts to be noted and legislative changes are being made. However, the main problem is there isn't any necessary and sufficient market</p>		

¹ **MB** = Member body / **NC** = National Committee (enter the ISO 3166 two-letter country code, e.g. CN for China; comments from the ISO/CS editing unit are identified by **)

² **Type of comment:** **ge** = general **te** = technical **ed** = editorial

TSE (Turkey) comments on the Survey of ISO/COPOLCO WG 18 “Consumer issues in standardization of services”

Date:	Document:	Project:
-------	-----------	----------

MB/NC ¹	Line number (e.g. 17)	Clause/ Subclause (e.g. 3.1)	Paragraph/ Figure/ Table/ (e.g. Table 1)	Type of comment ²	Comments	Proposed change	Observations of the secretariat
					<p>surveillance to ensure the viability of these changes made; instead of encouraging the consumer organizations to play a more active role in these areas, they are being left to be ineffective and even without initiative.</p> <p>4- What other services do you consider to be a priority for international standardization?</p> <p>Our priority is to form a network of essential communication and coordination channel/s between the Consumers, Consumer organizations, and the Public Administrators (legislation on the consumer law enforcement); the adoption of such governance (mutual management) and implementation of this approach will enable it. As a result, can help out with eliminating the weak consumer organizations and ensuring the institutionalization; to develop standards to be able to provide the Right to Representation services in Consumer supreme courts/councils is also our main concern.</p>		

¹ **MB** = Member body / **NC** = National Committee (enter the ISO 3166 two-letter country code, e.g. CN for China; comments from the ISO/CS editing unit are identified by **)

² **Type of comment:** **ge** = general **te** = technical **ed** = editorial

TSE (Turkey) comments on the Survey of ISO/COPOLCO WG 18 “Consumer issues in standardization of services”

Date:	Document:	Project:
-------	-----------	----------

MB/NC ¹	Line number (e.g. 17)	Clause/ Subclause (e.g. 3.1)	Paragraph/ Figure/ Table/ (e.g. Table 1)	Type of comment ²	Comments	Proposed change	Observations of the secretariat
					<p>Prevention of consumer rights violations and having conscious consumers is dependent on the Consumer Organizations’ strength and effectiveness. For this purpose, government authorities and agencies should adopt the concept of synergy and be a partner in these matters.</p> <p>Neither related governmental agencies nor municipal departments take active role and do what is necessary to educate, train, inform, and protect the consumer; these agencies and departments do not pay enough attention to the consumer organizations and further, make it harder for these organizations to help out consumers get support and protection.</p> <p>5- What are the key issues for consumers in</p> <ul style="list-style-type: none"> • Clear and easy service purchase and application processes; • Easier service cancellation processes; • The services to be procured to be provided within a purpose and scope in an appropriate standardization; To have a 		

¹ **MB** = Member body / **NC** = National Committee (enter the ISO 3166 two-letter country code, e.g. CN for China; comments from the ISO/CS editing unit are identified by **)

² **Type of comment:** **ge** = general **te** = technical **ed** = editorial

TSE (Turkey) comments on the Survey of ISO/COPOLCO WG 18 “Consumer issues in standardization of services”

Date:	Document:	Project:
-------	-----------	----------

MB/NC ¹	Line number (e.g. 17)	Clause/ Subclause (e.g. 3.1)	Paragraph/ Figure/ Table/ (e.g. Table 1)	Type of comment ²	Comments	Proposed change	Observations of the secretariat
					<p>provision of availability of the right of withdrawal from the services offered;</p> <ul style="list-style-type: none"> • To have an assurance/guarantee that the service providers fulfill their commitment and offer sustainability in their services; • To have competition in the market place and that preventive steps are being taken against unfair competition and/or monopolization as well as necessary monitoring and supervision • Compliance with the principle of social state in areas of equality of public services, the basic necessary human needs, such as electricity and water, should be compensated by the state government for those consumers, who are on very low-income. <p>All of the above mentioned main problems are solid and to the utmost importance.</p>		

¹ **MB** = Member body / **NC** = National Committee (enter the ISO 3166 two-letter country code, e.g. CN for China; comments from the ISO/CS editing unit are identified by **)

² **Type of comment:** **ge** = general **te** = technical **ed** = editorial

Croatia - HZN Croatian Standards Institute Services consultation

1. Which services cause the most complaints for consumers in your country?

Services that cause the most complaints for consumers in Croatia are: electronic communication services, municipal services, power supply system services and financial services

2. Which services cause the greatest loss and/or harm for consumers in your country?

Financial services cause the greatest loss/or harm for consumers in Croatia.

3. What are the key issues for consumers in the provision of a service?

Security of the services, quality, costs, quick and simple possibilities to resolve consumer complaints are the key issues for consumers in the provision of a services.



Consumer snapshot

Advice trends in Scotland



CONSUMER SNAPSHOT 2014/15

Case evidence and statistics from the Scottish CAB Service

by Patrick Hogan, Policy Officer

Contents

Intro: A snapshot of consumer issues	p3
Part 1: A review of 2014/15	p4
Key statistics April 2014-March 2015	p4
Current trends	p4
Hotspot map	p5
Difference with rest of Great Britain	p6
Part 2: Consumer statistics for 2014-15	p7
Top issues	p7
Increases and decreases	p8
Part 3: Consumer hotspots	p10
Top local authorities by call volume and proportion	p10
Appendix 1	p12
Top five issues by local authority	p12
Appendix 2	p17
Top 40 issues – bureaux	p17
Top 40 issues – helpline	p18
Appendix 3	p20
Local authority hotspots for select consumer issues	p20

Author and contact: Patrick Hogan, Policy Officer

T: 0131 550 1061 W: www.cas.org.uk, www.adviceguide.org.uk

Citizens Advice Scotland, Spectrum House, 2 Powderhall Road, Edinburgh, EH7 4GB

The Scottish Association of Citizens Advice Bureaux – Citizens Advice Scotland (Scottish Charity Number SC016637)

A snapshot of consumer issues

This report provides a snapshot of the key issues that are affecting consumers in Scotland, examining both national and local trends in consumer issues. This is based on data provided by Citizens Advice Bureaux in Scotland and data from the Citizens Advice consumer service and covers the period from April 2014 to March 2015.

Citizens Advice Bureaux and the Citizens Advice consumer service

There are 61 member Citizens Advice Bureaux and over 250 advice points in Scotland, from the cities to the islands. Together with the Citizens Advice consumer service helpline means Scots enjoy the benefits of a connected consumer champion. Advice provided by our service is free, independent, confidential, impartial and available to everyone. In addition, our self-help website, Adviceguide, provides information on rights, helps people solve their problems and received approximately 5.4 million unique page views in 2014/15.

All told, the Citizens Advice Service in Scotland helped over 323,000 clients in 2014/15 and dealt with over 1 million advice issues. With support from the network, clients had financial gains of over £124 million. This includes support with issues relating to benefits, debt, housing, consumer goods and many others.

This report only looks at “consumer” related issues, including:

- Consumer debt
- Consumer goods and services
- Financial products and services
- Telecommunications
- Travel and transport
- Utilities

This report looks at all the issues from consumers in Scotland that were handled by the Citizens Advice consumer service helpline as well as the consumer issues dealt with by bureaux.

Part 1: A review of 2014/15

Key statistics April 2014 – March 2015

Between 1st April 2014 and 31st March 2015 the Citizens Advice Service helped consumers in Scotland with hundreds of thousands of consumer issues.

403,605 consumer issues advised on:

- 353,176 in Citizens Advice Bureaux
- 50,429 by the Citizens Advice consumer helpline

That's **1,601 consumer issues** every working day

Our top five consumer issues across the service were:

1. Debt remedies: 34,357
2. Credit, store and charge card debts: 26,265
3. Housing arrears (rent, mortgage): 21,181
4. Unsecured loans: 18,760
5. Energy: 17,923

In 2014/15, we saw the following areas of advice see big increases and decreases compared to the previous year:

Community care	+52%
Parking issues	+45%
Pensions, savings & investments ¹	+41%
Public transport	+38%
Summary cause proceedings	+36%
<hr/>	
Bank and building society overdrafts	-20%
Payment protection insurance	-21%
Mortgage arrears	-30%
Payday loan debts	-31%
Multiple secured loan arrears	-35%

¹ This includes enquiries from clients seeking advice from the UK Government's Pension Wise service which is currently delivered through CABs in Scotland.

Consumers in different parts of Scotland can experience different issues depending on where they live. The map below highlights some of the regional differences in 2014/15 as reflected in calls to the consumer helpline:

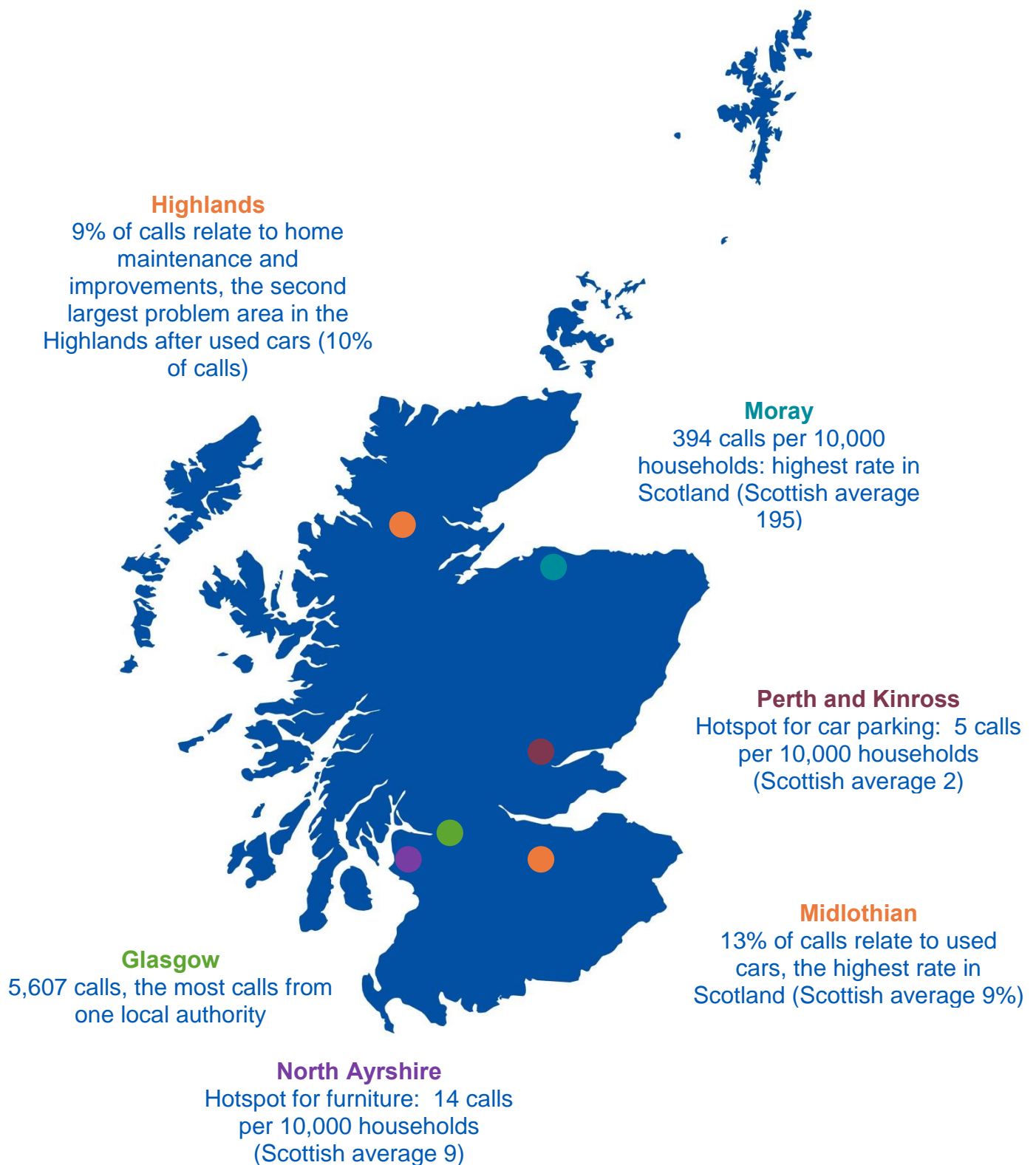

In addition to this, using helpline data from our sister organisation Citizens Advice, we can see what Scottish consumers were more likely to seek advice on compared to their counterparts across Great Britain.

In 2014/15, we found that the biggest differences were:



More common in Scotland:

- Domestic fuel (+84%)
- Time shares (+42%)
- House construction (+34%)
- Betting, competitions and prize draws (+20%)
- Textiles and soft furnishings (+12%)

Less common in Scotland:

- Disability aids (-58%)
- Books, newspapers and magazines (-50%)
- Broadcasting (-46%)
- Estate agents (-46%)
- Home-working and gifting schemes (-44%)

Historically, calls related to domestic fuel (gas and electricity) have typically tended to be higher in Scotland than when compared to the rest of GB, a trend we see continuing in 2014/15. This might be explained by a number of factors, including ongoing problems with customer service and billing systems experienced by some suppliers with a large market share in Scotland and the continuing high profile of the energy market in general in the media.

Issues in the house construction category relate to new house construction and purchase, land and guarantees related to new housing. Given this, the higher percentage of calls related to house construction from Scottish callers may have something to do with the fact that over 2014/15, Scotland saw new builds completed at a higher rate than in England and Wales, rather than due to any fundamental flaws in the way homes are built north of the border.

However, the comparatively lower number of calls in relation to estate agents is likely due to the different system for buying and selling homes in Scotland and the safeguards Scottish procedures provide against delays in housing 'chains'. In addition, the amount of information given to prospective home buyers (like Home Reports) also can be seen to contribute to a relatively transparent transactional process compared to the rest of GB which helps avoid common problems from manifesting themselves.

Part 2: Consumer statistics for 2014/15

Figures 1 and 2 below provide an overview of the top issues seen at bureaux and through the consumer helpline. As can be seen, bureaux are much more likely to deal with debt, housing and finance issues while the helpline is more likely to deal with problems related to consumer goods and services.

Figure 1: Top ten consumer issues brought to bureaux from April 2014 to March 2015

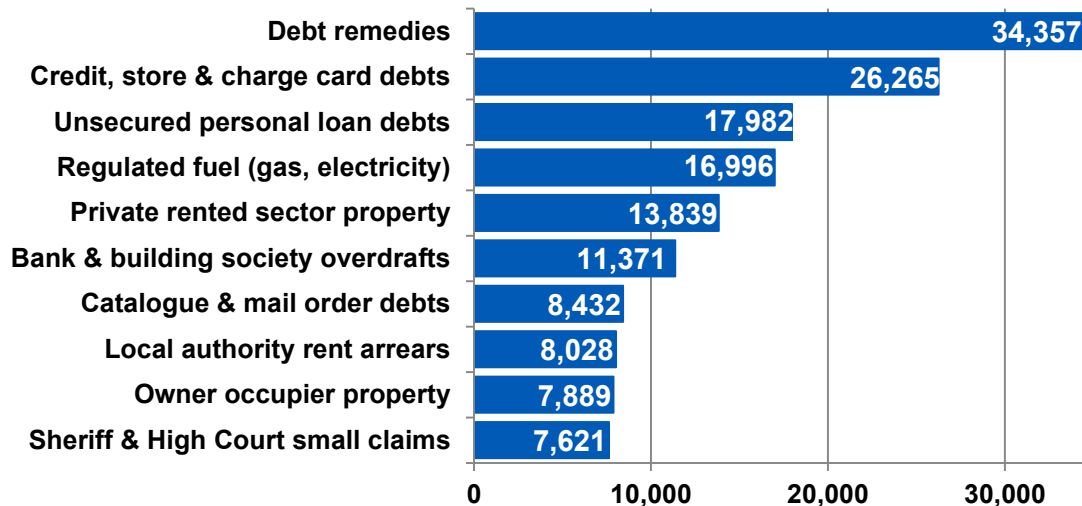

Figure 2: Top ten Citizens Advice consumer helpline issues from Scottish consumers from April 2014 to March 2015

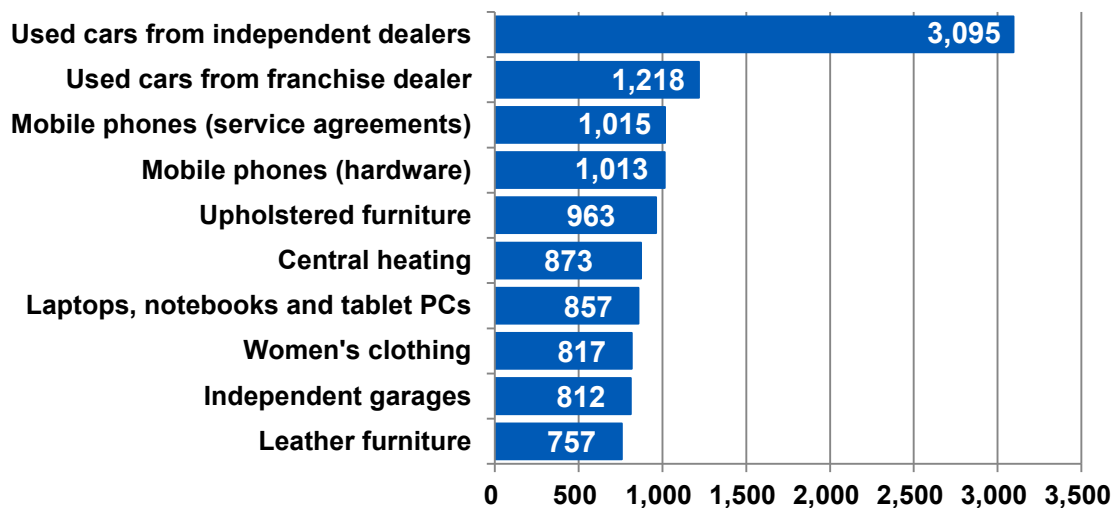

Figure 3: Increases and decreases in advice for bureaux and the consumer helpline in selected areas compared to the previous year

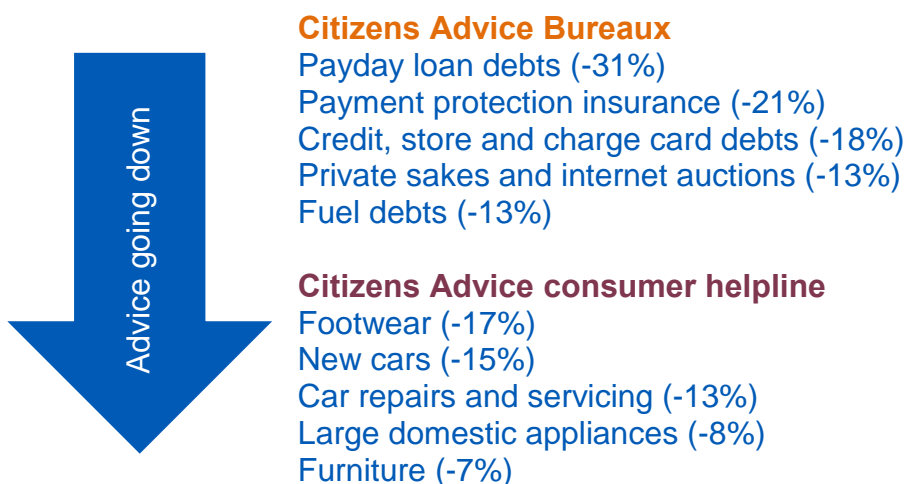
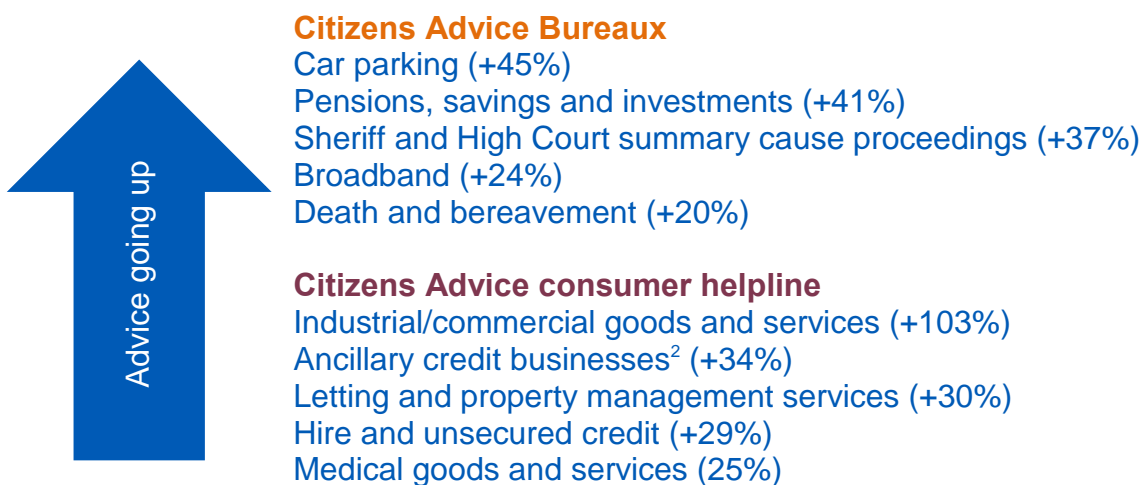

Figure 3 above highlights some selected key trends we have seen at both bureaux and through the helpline over 2014-15, some of which help illustrate the impact of recent CAS consumer campaigns. For instance, rises in the number of cases seen relating to car parking and death and bereavement can be at least partly explained by the public awareness brought to these issues as a result of our campaigning efforts on unfair car parking charges and funeral poverty. Similarly, the decline in the number of payday loan debt problems seen can be as

² Including credit brokers, credit reference agencies, credit repair, debt collectors and debt adjusting.

a result of the action taken by CAS and others over a number of years to make the industry fairer for consumers.

It is also worth highlighting that the figures above also call attention to the changing nature of debt in Scotland. For instance, though debt cases are falling, cases related to Sheriff and High Court summary cause proceedings are increasing, driven in large measure by a 44% increase in proceedings for rent arrears evictions. This suggests that debt remains a problem in Scotland and is manifesting itself in different ways, most especially by way of increases in priority debt cases.

Some trends, however, are more difficult to interpret. For example, the drop in footwear helpline cases is puzzling, but may simply represent a one year phenomenon. At the other end of the spectrum, it is not clear why helpline cases related to industrial and commercial goods and services increased at such a high rate, though it may be explained in part by the comparatively few number of cases we see in this category (396 cases in 2014/15 compared to 195 cases in 2013/14).

Part 3: Consumer hotspots

We are able to further drill down into the data from the Citizens Advice consumer helpline by looking at the type and number of issues by local authority area. Unsurprisingly, the number of calls from any particular local authority area generally corresponds to the size of that local authority in population terms.

Table 1: Top ten local authorities by number of issues handled by the consumer helpline

Local authority	N
Glasgow City Council	5,036
City of Edinburgh Council	3,852
Fife Council	3,473
North Lanarkshire Council	2,665
South Lanarkshire Council	2,588
Aberdeenshire Council	2,524
Highland Council	2,297
Aberdeen City Council	1,794
West Lothian Council	1,781
Falkirk Council	1,699

However, Table 2 looks at the number of issues handled by the consumer helpline service by local authority but accounts for population by examining the proportion of local people contacting the helpline service in each local authority area.

Table 2: Top ten local authorities by number of consumer issues per 10,000 households

Local authority	N
Moray Council	394
North Ayrshire Council	266
Aberdeenshire Council	261
Highland Council	251
Falkirk Council	245
West Lothian Council	241
Angus Council	241
Dundee Council	241
Scottish Borders Council	232
Fife Council	222

Looking at these numbers, it becomes clear that those in rural and town areas are more likely to use the helpline compared with those in cities, though Dundee provides a notable exception to this general observation.³

For further analysis of local authority figures, Appendix 1 at the end of this report examines the top five issues for each local authority area across Scotland. In nearly every single area, concerns about used cars dominate, with vehicle servicing also featuring highly across a number of areas. Concerns related to mobile phone hardware and service agreements can also be found readily across the country, while rural areas are more likely to have problems related with an aspect of housing (such as central heating or roofing).

In addition, Appendix 2 breaks down into detail the top 40 consumer issues seen by bureaux and the consumer helpline over the period 2014-15, giving a further indication of the types of issues typically handled by both services.

Appendix 3 highlights some of the regional variances found in key helpline categories expressed both in terms of calls per household as well as a percentage of overall calls for that particular area. The figures help illustrate some of the more common areas of concern as well as certain individual or regional hotspots for certain problems.

³ For comparison, Dundee's figure of 241 calls per 10,000 households is much more robust than for other urban areas like Aberdeen (184), Edinburgh (181) or Glasgow (179), all of which are below the Scottish average of 195 calls per 10,000 households.

Appendix 1: Top five issues by local authority

Aberdeen City Council	1,794
Used car purchased from an independent dealer	126
Mobile phones (hardware)	48
Used car purchased from a franchise dealer	45
General building work	43
Vehicle repairs/servicing at an independent garage	40
Aberdeenshire Council	2,524
Used car purchased from an independent dealer	225
Used car purchased from a franchise dealer	67
General building work	55
Vehicle repairs/servicing at an independent garage	55
Landline telephone services	51
Angus Council	1,105
Used car purchased from an independent dealer	94
Vehicle repairs/servicing at an independent garage	28
Mobile phones (hardware)	27
Central heating	27
Used car purchased from a franchise dealer	26
Argyll and Bute Council	730
Used car purchased from an independent dealer	54
Used car purchased from franchise dealer	21
Women's clothing	16
Laptops, notebooks and tablet PCs	15
Central heating	15
Clackmannanshire Council	252
Used car purchased from an independent dealer	13
Credit agreements/loans (not linked)	10
Used car purchased from a franchise dealer	9
Non-upholstered furniture	7
Replacement doors (housing)	5
Comhairle Nan Eilean Siar	258
Used car purchased from an independent dealer	20
Landline telephone services	6
Internet service providers	6
Advertising agencies	5
Cosmetics	5

Dumfries and Galloway Council	1,182
Used car purchased from an independent dealer	92
Used car purchased from a franchise dealer	39
Mobile phones (hardware)	28
Mobile phones (service agreements)	26
Laptops, notebooks and tablet PCs	26
Dundee City Council	1,400
Used car purchased from an independent dealer	101
Mobile phones (hardware)	45
Laptops, notebooks and tablet PCs	33
Leather furniture	29
Mobile phones (service agreements)	28
East Ayrshire Council	590
Used car purchased from an independent dealer	40
Mobile phones (service agreements)	22
Credit agreements/loans (not linked)	19
Women's clothing	14
Double glazing	13
East Dunbartonshire Council	685
Used car purchased from an independent dealer	42
Women's clothing	22
Mobile phones (service agreements)	19
Central heating	18
Upholstered furniture	16
East Lothian Council	858
Used car purchased from an independent dealer	65
Used car purchased from a franchise dealer	34
Vehicle repairs/servicing at an independent garage	24
Central heating	21
Upholstered furniture	19
East Renfrewshire Council	844
Used car purchased from an independent dealer	38
General building work	29
Roofing	27
Used car purchased from a franchise dealer	24
Women's clothing	21
Edinburgh Council, City of	3,852
Used car purchased from an independent dealer	212
Mobile phones (service agreements)	109
Mobile phones (hardware)	103
General building work	95
Central heating	80

Falkirk Council	1,699
Used car purchased from an independent dealer	130
Upholstered furniture	50
Central heating	47
Used car purchased from a franchise dealer	46
Mobile phones (service agreements)	40
Fife Council	3,473
Used car purchased from an independent dealer	276
Used car purchased from a franchise dealer	99
Upholstered furniture	78
Central heating	77
Mobile phones (hardware)	76
Glasgow City Council	5,036
Used car purchased from an independent dealer	255
Mobile phones (hardware)	148
Used car purchased from franchise dealer	141
Mobile phones (service agreements)	133
Upholstered furniture	128
Highland Council	2,297
Used car purchased from an independent dealer	157
Used car purchased from a franchise dealer	61
Vehicle repairs/servicing at an independent garage	60
General building work	45
Landline telephone services	45
Inverclyde Council	720
Used car purchased from an independent dealer	53
Upholstered furniture	24
Used car purchased from a franchise dealer	18
General building work	17
Leather furniture	17
Midlothian Council	712
Used car purchased from an independent dealer	72
Used car purchased from a franchise dealer	28
Vehicle repairs/servicing at an independent garage	15
Mobile phones (service agreements)	15
Upholstered furniture	14
Moray Council	1,359
Used car purchased from an independent dealer	93
Double glazing	38
Landline telephone services	36
Used car purchased from a franchise dealer	31
Vehicle repairs/servicing at an independent garage	29

North Ayrshire Council	1,571
Used car purchased from an independent dealer	117
Mobile phones (hardware)	44
Upholstered furniture	43
Used car purchased from a franchise dealer	37
Laptops, notebooks and tablet PCs	36
North Lanarkshire Council	2,665
Used car purchased from an independent dealer	156
Used car purchased from a franchise dealer	92
Leather furniture	83
Upholstered furniture	76
Mobile phones (service agreements)	70
Orkney Islands Council	42
Used car purchased from an independent dealer	3
Women's clothing	2
Vehicle spares and accessories	2
Electrical services and installations	2
Personal computers	2
Perth and Kinross Council	1,271
Used car purchased from an independent dealer	86
Roofing	39
Car parking and clamping	34
Used car purchased from a franchise dealer	30
Vehicle repairs/servicing at an independent garage	27
Renfrewshire Council	1,649
Used car purchased from an independent dealer	93
Upholstered furniture	47
Leather furniture	44
Mobile phones (hardware)	44
Used car purchased from franchise dealer	43
Scottish Borders Council	1,064
Used car purchased from an independent dealer	82
Central heating	26
Vehicle repairs/servicing at an independent garage	25
Mobile phones (service agreements)	20
Mobile phones (hardware)	20
Shetland Islands Council	54
Laptops, notebooks and tablet PCs	3
Vehicle air facilities	3
Credit agreements/loans (not linked)	3
Used car purchased privately	2
Used car purchased from a franchise dealer	2

South Ayrshire Council	555
Used car purchased from an independent dealer	37
Women's clothing	20
Used car purchased from a franchise dealer	16
Laptops, notebooks and tablet PCs	15
Mobile phones (service agreements)	15
South Lanarkshire Council	2,588
Used car purchased from an independent dealer	154
Used car purchased from a franchise dealer	88
Leather furniture	75
Mobile phones (service agreements)	61
Central heating	60
Stirling Council	411
Used car purchased from an independent dealer	26
Central heating	11
Women's clothing	11
Used car purchased from a franchise dealer	10
Credit brokers	10
West Dunbartonshire Council	790
Used car purchased from an independent dealer	37
Upholstered furniture	29
Credit agreements/loans (not linked)	21
Central heating	20
Used car purchased from a franchise dealer	19
West Lothian Council	1,781
Used car purchased from an independent dealer	144
Mobile phones (hardware)	55
Used car purchased from a franchise dealer	54
Mobile phones (service agreements)	53
Upholstered furniture	47

Appendix 2: Top 40 issues seen at bureaux and through the helpline

Top 40 consumer issues seen at Citizens Advice Bureaux April 2014 – March 2015

Issue	Count
Debt remedies	34,357
Credit, store and charge card debts	26,265
Unsecured personal loan debts	17,982
Regulated fuel (gas, electricity)	16,996
Private rented sector property	13,839
Bank and building society overdrafts	11,371
Catalogue and mail order debts	8,432
Local authority rent arrears	8,028
Owner occupier property	7,889
Sheriff and High Court small claims proceedings	7,621
Local authority housing	7,136
Fuel debts	6,436
Telephone debts	6,190
Main mortgage arrears	5,884
Sheriff + High Court: summary cause proceedings	5,821
Payday loan debts	5,576
Registered social landlord rent arrears	5,512
Solicitors/advocates	5,217
Parking	4,885
Bank, building society and Post Office accounts	4,677
Environmental and neighbour housing issues	4,607
Registered social landlord property	3,853
Pensions, savings and investments	3,708
Death and bereavement	3,597
Building repairs and improvements	3,571
Community care	3,243
Health costs, charges and entitlements	2,689
Driving	2,468
Electrical appliances and repairs	2,362
New and second hand vehicles	2,254
Compensation redress	2,162
Payment protection insurance	2,161
Incapacity legal arrangements	2,011
Private rented sector arrears	1,757
Furnishings and floor coverings	1,708
Public transport	1,644
Information about health services	1,555

Mobile phones	1,549
Personal-related court proceedings	1,522
Hire purchase arrears	1,483

***Top 40 consumer issues handled by the Citizens Advice consumer helpline
April 2014 – March 2015***

Issue	Count
Used cars from independent dealers	3,095
Used cars from franchise dealer	1,218
Mobile phones (service agreements)	1,015
Mobile phones (hardware)	1,013
Upholstered furniture	963
Central heating	873
Laptops, notebooks and tablet PCs	857
Women's clothing	817
Independent garages	812
Leather furniture	757
Double glazing	746
General building work	741
Credit agreements and loans (not linked)	655
Landline telephone services	633
Roofing	614
Fitted kitchens	552
Beds and mattresses	550
Non-upholstered furniture	544
Credit brokers	521
TVs	499
Overseas package holidays	473
Slimming products/services	454
Car parking and clamping	419
New cars from franchise dealer	406
Fitted bathrooms	383
Internet service providers	383
Jewellery (including repairs)	367
Vehicle spares and accessories	360
Used cars purchased privately	357
Beauty treatments	355
Washing machines	352
Plumbers and plumbing	350
Car insurance	346
Lotteries	332
Hotels, guest houses and bed and breakfasts	309
Fridges and freezers	298
Carpets	297

Animals and pets	296
Insulation	294
Electricity	279

Appendix 3: Local authority hotspots for select consumer issues

Home maintenance and improvements

Local authority	Calls per 10k households
East Renfrewshire Council	37
Falkirk Council	33
Moray Council	33
Aberdeenshire Council	30
Angus Council	29
<i>Scottish average</i>	19

Local authority	Percentage of total calls
East Renfrewshire Council	16%
Orkney Islands Council	15%
Falkirk Council	12%
Fife Council	12%
Angus Council	12%
<i>Scottish average</i>	9%

Car parking

Local authority	Calls per 10k households
Perth & Kinross Council	5
Dundee City Council	3
Renfrewshire Council	2
North Ayrshire Council	2
Scottish Borders Council	2
<i>Scottish average</i>	1

Local authority	Percentage of total calls
Perth & Kinross Council	2%
Dundee City Council	1%
Stirling Council	1%
Clackmannanshire Council	1%
South Ayrshire Council	1%
<i>Scottish average</i>	0.8%

Central heating

Local authority	Calls per 10k households
Falkirk Council	6
Moray Council	6
Angus Council	5
Scottish Borders Council	5
West Lothian Council	4
<i>Scottish average</i>	3

Local authority	Percentage of total calls
Falkirk Council	2%
Stirling Council	2%
East Dunbartonshire Council	2%
West Dunbartonshire Council	2%
Angus Council	2%
<i>Scottish average</i>	1%

Furniture

Local authority	Calls per 10k households
North Ayrshire Council	14
Falkirk Council	13
Renfrewshire Council	13
West Lothian Council	13
North Lanarkshire Council	13
<i>Scottish average</i>	9

Local authority	Percentage of total calls
North Lanarkshire Council	6%
West Dunbartonshire Council	6%
Renfrewshire Council	6%
South Lanarkshire Council	6%
Inverclyde Council	6%
<i>Scottish average</i>	4%

Hire and unsecured credit

Local authority	Calls per 10k households
Dundee City Council	6
West Dunbartonshire Council	5
North Lanarkshire Council	5
East Ayrshire Council	5
Moray Council	5
<i>Scottish average</i>	3

Local authority	Percentage of total calls
Shetland Islands Council	5%
East Ayrshire Council	4%
Clackmannanshire Council	3%
West Dunbartonshire Council	2%
North Lanarkshire Council	2%
<i>Scottish average</i>	1%

Letting agents

Local authority	Calls per 10k households
Renfrewshire Council	4
Glasgow City Council	3
Dundee City Council	2
Edinburgh City Council	2
Inverclyde Council	2
<i>Scottish average</i>	1

Local authority	Percentage of total calls
South Ayrshire Council	1%
Clackmannanshire Council	1%
Renfrewshire Council	1%
Glasgow City Council	1%
Stirling Council	1%
<i>Scottish average</i>	0.8%

Used cars

Local authority	Calls per 10k households
Moray Council	35
Aberdeenshire Council	30
Falkirk	28
Midlothian Council	28
West Lothian Council	26
<i>Scottish average</i>	<i>19</i>

Local authority	Percentage of total calls
Midlothian Council	13%
Aberdeenshire Council	11%
East Lothian Council	11%
Dumfries & Galloway Council	11%
West Lothian Council	11%
<i>Scottish average</i>	<i>9%</i>

Women's clothing

Local authority	Calls per 10k households
Falkirk Council	5
East Renfrewshire Council	5
East Dunbartonshire Council	4
Moray Council	4
Renfrewshire Council	4
<i>Scottish average</i>	<i>3</i>

Local authority	Percentage of total calls
Orkney Islands Council	4%
South Ayrshire Council	3%
East Dunbartonshire Council	2%
Stirling Council	2%
East Renfrewshire Council	2%
<i>Scottish average</i>	<i>1%</i>

Citizens Advice Scotland and its member bureaux form Scotland's largest independent advice network. CAB advice services are delivered using service points throughout Scotland, from the islands to city centres.

The CAB Service aims:

to ensure that individuals do not suffer through lack of knowledge of their rights and responsibilities, or of the services available to them, or through an inability to express their need effectively

and equally

to exercise a responsible influence on the development of social policies and services, both locally and nationally.

The CAB Service is independent and provides free, confidential and impartial advice to everybody regardless of age, disability, gender, race, religion and belief and sexual orientation.

www.cas.org.uk

info@cas.org.uk

www.facebook.com/scottishcabservice

www.twitter.com/scottishcabservice

Produced by The Scottish Association of Citizens Advice Bureaux -
Citizens Advice Scotland (Scottish charity number SC016637)
Spectrum House, 2 Powderhall Road, Edinburgh EH7 4GB
Tel: 0131 550 1000

Copyright © Citizens Advice Scotland 2016

No part of this publication may be reproduced without prior permission except for purposes of review or referral.



International Organization for Standardization
Organisation internationale de normalisation
Международная организация по стандартизации

NEW WORK ITEMS AND ISSUES – WORKING GROUPS



International Organization for Standardization
Organisation internationale de normalisation
Международная организация по стандартизации

AGENDA ITEM 10 REVISION OF ISO/IEC GUIDE 76

AGENDA ITEM 10 Revision of ISO/IEC Guide 76

COPOLCO ACTION: COPOLCO members are invited to comment on the definition of service, and approve the restructuring and follow-up actions for ISO/IEC Guide 76 as proposed in this report and draft resolution.

ISO/COPOLCO Working Group 18, *Consumer issues in standardization of services* held a two day meeting in March 2016, and focused mainly on the revision of ISO/IEC Guide 76. Several key issues were discussed. Considering the use of ISO/IEC Guides by Technical Committees and Working Groups, the WG's aim would be to promote the Guide's use by making Guide 76 more user-friendly. The current scope of ISO/IEC Guide 76 is a consumer-facing guide produced by a COPOLCO Working Group, whereas CEN Guide 15 is designed for use by all stakeholders and makes direct reference to European legislation. Revising ISO/IEC Guide 76 to include the wider interests of all stakeholders (as CEN Guide 15) would be outside the scope of ISO/COPOLCO, so it is proposed to maintain Guide 76 as a consumer guide. Hence, the title is changed to "Development of services standards – how to address consumer issues". The definition of service and the structure of ISO/IEC Guide 76 were also considered.

As a basis for restructuring ISO/IEC Guide 76, examples of the structures of some existing national service standards are presented. ISO/COPOLCO Working Group 18 is working on the first draft of the ISO/IEC Guide 76. It is planned that the initial redraft will be sent to members for comments before the plenary meeting in 2016.

The unconfirmed minutes of the meeting appear at **Annex 1**. Definitions of "service" appear **overleaf**, with a proposed new definition for discussion at **Annex 2**. The structure of the Guide appears at **Annex 3**. Examples of existing national service standard structures appear at **Annex 4**.

Draft resolution X/2016

COPOLCO WG 18, Consumer issues in services standardization (2) – ISO/IEC Guide 76

COPOLCO

approves the proposed restructuring and planned actions outlined in this report, with addition of comments made at the meeting,

requests members to comment on the first draft of the revision of ISO/IEC Guide 76, *Development of service standards -- Recommendations for addressing consumer issues* when balloted to members,

invites ISO/COPOLCO WG 18, *Consumer issues in services standardization* to continue revising ISO/IEC Guide 76, taking into account discussions at the 2016 COPOLCO Plenary.

Annex 1: Unconfirmed minutes of the WG 18 meeting, 1-2 March 2016 (WG 18/N16)

Annex 2: Definition of service (WG18/N14)

Annex 3: Revision of Guide 76 – proposed structure (WG18/N15)

Annex 4: Examples of the structure of existing services standards

Some currently-existing definitions of “service”

ISO/IEC Guide 76 (currently published version).

3.1

service

result of at least one activity, necessarily performed at the interface between the supplier and customer, that is generally intangible

NOTE 1 Examples of possible services are given in Annex A.

NOTE 2 In ISO 9000, “product” is defined as the “result of a process” that encompasses four generic product categories [services (e.g. transport), software (e.g. computer program, dictionary), hardware (e.g. engine mechanical part) and processed materials (e.g. lubricant)] and that indicates that the product category used is based on the dominant element. A service can therefore include the delivery of software, hardware and processed materials. For the purposes of this Guide, a separate definition of “service” is given here.

ISO 26000

2.16 service: action of an organization (2.12) to meet a demand or need

PRODUCT: article or substance that is offered for sale or is part of a service delivered by an organization (2.12)

ISO/IEC GUIDE 14

service: result of activities between a supplier and a client, and the internal activities carried out by the supplier to meet the requirements of the client

product: manufactured article intended for a customer

ISO/IEC CD Guide 14 NEW:

2.3. Consumer service result of any activity undertaken or performed by a supplier and the internal activities carried out by the supplier for the benefit of, or to meet the requirements of, the consumer

ISO GUIDE 37: Guide 14 terms and definitions apply

ISO/IEC 20000-1 Information technology — Service management — Part 1: Service management system requirements

service: means of delivering value for the customer by facilitating results the customer wants to achieve

EU Regulation N.1025/2012 ‘service’ means any self-employed economic activity normally provided for remuneration, as defined in Article 57 TFEU [Article 57 TFEU] ‘Services’ shall in particular include:

- (a) activities of an industrial character;
- (b) activities of a commercial character;
- (c) activities of craftsmen;
- (d) activities of the professions]

EU Directive on service (Directive 2006/123/EC) ‘service’ means any self-employed economic activity, normally provided for remuneration, as referred to in Article 50 of the Treaty.

CEN Guide 15

2.14 service standard: standard that specifies requirements to be fulfilled by a service, to establish its fitness for purpose [EN 45020:1998]

Note 1 to entry: Service standards can include both specific requirements on the service (measurable) and organisation procedures in place for repeated or continuous application to ensure that the service level is reached.

Note 2 to entry: A service standard can describe requirements for the service or part of it, and it can establish service levels or categories.



DRAFT AGENDA – COPOLCO Working Group, “Consumer Issues in Services” – 16 June 2016 – Mövenpick Hotel, Geneva, Switzerland, starting at 15:00

Item		Document	Rapporteur
1.	Welcome and introductions, adoption of the agenda		Chengyang Liu
2.	Revision of ISO/IEC Guide 76 - scope of the Guide - definition of the services - selection of key elements - comments on the first draft	N209	Gretel Jones Arnold Pindar
3.	Survey on consumer priorities in standardization on services - report on the survey - comments and feedback on the survey		Chengyang Liu
4.	Workplan of WG - report on the workplan - discussion on the work		Lili Cao
5.	Other business		
6.	Close		

**UNCONFIRMED MINUTES OF THE 2nd MEETING OF COPOLCO WG 18,
“Consumer issues in standardization of services”
Geneva (Switzerland), 1-2 March 2016**

ISO/COPOLCO/WG 18 N 16

Present:

Mr Arnold Pindar	BSI (United Kingdom), ANEC, Co-convenor
Ms Lili Cao	SAC (China), deputizing for Ms. Chengyang Liu, co-convenor
Ms Gretel Jones	ANEC
Mr Jelte Dijkstra	NEN (Netherlands)

By WebEx:

Ms Elena Mocchio	UNI (Italy)
------------------	-------------

Excused:

Mr Keith Lewis	BSI, United Kingdom
Ms Kristina Unverricht	DIN, Germany
Ms Suzanna Ersoy	SCC, Canada

Central Secretariat:

Ms Dana Kissinger-Matray	Secretary of COPOLCO
--------------------------	----------------------

ITEM 1 Welcome and introductions, adoption of the agenda

Arnold Pindar, co-convenor, opened the meeting. The participants introduced themselves.

The participants adopted N12. In the context of the revision of ISO/IEC Guide 76, *Development of service standards -- Recommendations for addressing consumer issues*, the participants decided to start the meeting with a discussion of the use of Guides in general, and therefore inverted Agenda items 2 and 5.

ITEM 2 Concerns with use of ISO/IEC Guides by Technical Committees and Working Groups

Promote Guides' use

The participants noted that ISO/IEC Guides as a whole, although very useful, were not widely known or used. It had taken time even for those present at the meeting to learn about and use them. Standards therefore do not adequately reflect Guides' recommendations because they are either considered too late in standards drafting or not at all.

Make Guide 76 more user-friendly

Specifically for ISO/IEC Guide 76, some concepts are difficult to understand outside of the consumer movement. The Guide is not easy for TC experts to use. Guide 76 needed to be simplified and adapted to the perspective of a TC expert.

The participants therefore recommended that:

- 1) Committee Secretaries and National Standards Bodies needed to be educated about Guides so that they promote experts' use of Guides as a matter of course.
- 2) The revised Guide 76 should use less text and more checklists, and a different structure (see below).

Dana Kissinger-Matray summarized the Guides' development process and clarified that after the draft is circulated to COPOLCO (Committee Draft), the final stage is the Draft Guide stage (Enquiry), during which National Standards Bodies of ISO and IEC vote and comment. This is the final stage of development before publication.

ITEM 3 Scope for the revised ISO/IEC Guide 76

Arnold Pindar clarified that ISO/IEC Guide 76 and CEN Guide 15 could not be combined into a single revision, as they were fundamentally different in scope. ISO/IEC Guide 76 is a consumer-facing guide produced by a COPOLCO Working Group, whereas CEN Guide 15 is designed for use by all stakeholders and makes direct reference to European legislation.

Consumer-focused

The group considered whether COPOLCO should propose developing services standardization guidance for a wider range of stakeholder groups than only consumers in the future, but decided that ISO/IEC Guide 76 itself would focus on the consumer stakeholder group, in line with COPOLCO's mandate.

A different type of Guide would need development in another Committee; this could be a future recommendation from COPOLCO. For example, the group noted that ISO was organizing a workshop on standardization of service on 13-14 June 2016 in Geneva, directly preceding the COPOLCO Plenary. Such a proposal could be an outcome of the workshop.

The participants agreed that a better understanding of service definitions and categories was necessary both for ISO and CEN. There is no internationally harmonized classification system for services, yet there are many project committees related to services and issues being addressed. More order is needed.

Exclusion of specific professional competence and management systems requirements

The group decided to exclude professional competence and management systems requirements from the scope of the revised ISO/IEC Guide 76.

Many currently-existing standards for services included detailed provisions on the professional competence of the service provider, and management systems requirements for the organization providing the service. This is not good standards-writing practice. Standards for products, by contrast, generally avoid that confusion. While services differ from products (goods), the actual approach of standardization is the same. Requirements should therefore focus on the process to deliver the service and/or the performance requirements, the outcome of the service.

Furthermore, consumers already assume the competence of personnel providing the service, and are less interested in specific requirements leading to competence.

ITEM 3 Proposal for restructuring ISO/IEC Guide 76

The group decided make the revised ISO/IEC Guide 76 specific to the end-user: the standards-writer. At Jelte Dijkstra's suggestion, they agreed to delete general recommendations as much as possible as these are not helpful for TC experts. They also agreed to Gretel Jones' suggestion to:

- 1) identify consumer principles based largely on Consumers International's eight consumer rights (with some amendments), rather than those in the current version of ISO/IEC Guide 76;
- 2) identify basic elements of services (e.g. billing), taking certain clauses from CEN Guide 15 as a basis;
- 3) develop a matrix combining these consumer principles and elements, as a type of checklist.

Among the consumer rights, the group clarified that "Quality" was not a right as such but a desirable outcome to be treated in the Guide. Furthermore, different levels of quality may be acceptable, depending on the price the consumer pays. "Access" was also understood in a wider sense, i.e. fairness and consideration for the user of a service.

The group considered N 13 and modified it. The amended version is N 15.

ITEM 4 Content of revised ISO/IEC Guide 76

Arnold Pindar and Gretel Jones will develop the first working draft based on the revised structure. The group discussed various parts of the future revision, as follows:

Working Title: Development of services standards – how to address consumer issues.

Introduction: It needs to be shorter (remove text on meeting needs of consumers from the introduction), and explain why services are different from products (goods). There will be mention of the "intangibility" of a service. Lili Cao cited the recently revised ISO 14001 standard which makes a distinction between products and services, but mentions "intangible product". The group noted that the Internet is changing the characteristics of services, e.g. they can be stored on the Internet and therefore do not automatically occur at the interface between the provider and user. People have different perceptions of services. It was useful to mention conformity assessment's role in measuring delivery of the service.

Scope: no provisions on personnel, training and attitude from Guide 76 (see above).

Normative references: this clause is not necessary.

Definitions: the group observed that CEN Guide 15 does not give a definition of 'service'. It considered various definitions of service, including Lili's submission (N 14) .the definition from ISO/IEC Guide 14, ISO 26000, and CEN Guide 15 (3.5). The Guide 76 definition, including "intangible", will be reconsidered. Elena Mocchio volunteered to send the references she cited to the group for subsequent distribution to the members (NOTE: this has been done).

General provisions

Questions: The questions in Table 1 of the current Guide 76 are not very helpful to a standards-writer: the "Who? What? Why?" approach in CEN Guide 15 is more practical because it helps to design a standard rather than deliver a service.

Consumer rights: the meaning of choice, information, safety, access and redress has evolved since their original formulation in 1962. “Consumer education”, which is out of scope, will not be included in Guide 76. “Representation” was kept as it supports the principle of consumers’ participation in standards development. “Environmental issues” will be superseded by “sustainability”, referring to the Brundtland Commission definition of sustainable development (used in ISO Guide 82). “Safety” should be understood more widely than just product safety (it now includes personal security, online data security and privacy).

“Quality” was felt as different to a right, because the expectations vary according to price. The idea is more closely related to fitness for purpose. Quality means different things to different people, and it is better considered as an “output” of the service.

The group agreed to bring small subjects together under larger headings.

ISO/IEC Guide 14, *Purchase information on goods and services intended for consumers* deals with provision of information to consumers. It is being revised and a Committee Draft is now ready for consultation. The group decided not to make it a normative reference; Guide 14 will be mentioned in notes and the Bibliography. Some content can be reproduced from ISO/IEC CD Guide 14.

The group will consider whether or not to frame the key elements of service provision into questions.

General principles

The Guide will be drafted in a way that allows the standardizer to decide which aspects of a process to include in a specific standard for a service.

It is the result, and redress mechanisms, that are important for the consumer rather than the stages. The group therefore adopted Elena Mocchio’s suggestion to include a general statement about designing a service standard in terms of several possible approaches: one is defining the main stages of a process, and another is defining the performance requirements of a standard.

Note: see the ISO/IEC Directives, Part 2, clause 4.2. for the “performance approach”.

The group discussed “process” and Lili Cao agreed to draft some content for this.

The group agreed to study some currently existing standards for services to help with structuring Guide 76. Jelte Dijkstra provided some background information about standardization mandates in CEN and Elena Mocchio indicated that she would send some examples of national standards.

ITEM 5 Assessing consumers’ needs in services standardization: survey to COPOLCO members

The group noted that investigating consumer issues in service standards was the second part of the working group’s mandate from COPOLCO. Sending a survey to COPOLCO would be a good opportunity to gather information for the workshop. Arnold Pindar mentioned an ANEC report about cross border e-commerce issues. Gretel Jones referred to EN 13850 on track and trace mechanisms for cross-border mail parcels.

The participants agreed that the survey to COPOLCO members would comprise the following questions:

- 1) Which services cause the most complaints for consumers in your country?
- 2) Which services cause the greatest loss and/or harm for consumers in your country?

- 3) What national standards exist for services that you feel might be relevant and useful internationally (e.g. cross-border issues)?
- 4) What other services do you consider to be a priority for international standardization?
- 5) What are the key issues for consumers in the provision of a service?

ITEM 6 Discussion of the work plan of WG 18

First action items – output of the meeting

What	Who	By when
Draft some text on “process” for consideration by the Group	Lili Cao	30 March
Distribute definitions of “service” provided by Elena Mocchio, examples of regional and national standards	Dana Kissinger-Matray	30 March
Send examples of national standards for services for consideration of the structure	Elena Mocchio Lili Cao	7 April

Guide 76 actions

What	Who	By when
First working draft distributed to working group	Arnold and Gretel	1 June
Circulate the working draft to WG 18 for previous consultation and consideration	Dana	2 June
Discuss working draft	WG 18 at meeting	16 June
Consider ISO workshop outcomes	WG 18 at meeting Arnold, Lili and Gretel	16 June June-July
Develop second working draft	Arnold, Gretel	1 September
Circulate draft to WG 18 for consultation	Dana	Responses by 15 September
Corrections to 2 nd draft, finalize the draft	Arnold, Lili, Gretel	1 October
Circulate it to the Chair’s Group	Dana	1 November

Investigating consumer priorities in services

What	Who	By when
Design and disseminate survey to COPOLCO, CIB format,	Dana	15 March
Survey output to put on ISO commenting template if possible	Dana	15 April
Send results to Lili for comment	Dana	18 April
Write a short report based on results, send to Dana for working documents	Arnold with Lili	27 April
Finalize survey results and report for publication in COPOLCO working documents.	Dana	28 April
Ask for data on international trade from WTO GATS and what likely trends there are in services	Dana with other staff of ISO/CS	15 March
Investigate and report on service standards developed under European Mandates	Jelte Dijkstra	<i>Completed</i>

ITEM 7 ANY OTHER BUSINESS

There was no other business.

ITEM 8 CLOSURE

The co-convenors thanked participants and closed the meeting.

service

ISO/COPOLCO/WG 18 N 14

result of one or a series of activities, performed by providers interacting with customers (including the act itself and the process of interaction) with their physical strength, intelligence and/or skills, via the use of relevant tools, facilities, media and so on, aiming to meet the needs of customers

NOTE 1 The interface between the providers and customers includes many types, such as person to person, person to facilities, facilities to facilities, etc.

NOTE 2 The service is usually reflected in the results through the process.

Revision of Guide 76 – Proposed Structure

ISO/COPOLCO/WG 18 N 15

Title

Development of service standards – how to address consumer issues

Introduction

- Growth of service industry. *Add some data about consumers' use of services and why they are an important stakeholder group (data from the WEF?)*
- What are the characteristics of services? Intangible, complex
- What are service standards?
- Why they need to be tackled differently to product standards
- Aim to be inclusive

Standards are increasingly used to complement regulation, or as an alternative to regulation.

Scope

- The Guide gives guidance on addressing the needs of consumers in the development of standards for services. It can be applied to any service e.g. xxxxx, xxx, xxx
- This Guide does not include management system standards requirements
- This Guide does not cover professional competence requirements

Normative references

Terms and definitions

Using the guide/Before starting work on a standard

- Practical tips on how to use the guide
- The importance of understanding the key consumer principles of service planning and delivery. At each point where there is interaction between the organization and individual consumers
- Think about each step in the process – as detailed in following sections
- **Who, what, why?**

Key consumer principles/issues

A summary of the key principles that should be addressed in all service standards, where applicable/ relevant. List them with short description.

Key consumer principles:

- **Access** - to essential services such as utilities. Also respect, inclusivity, availability) Building accessibility, Accessibility in general (language, vulnerable persons) – refer to Guide 71 – refers to “who”.

- **Safety** - the right to safety, including privacy/security particularly in the online environment. This comprises: Personal data, Confidentiality, Computer systems, Risk assessments, Safety, Equipment used by consumers
- **Choice** – offer comparable and realistic options for selection of the service.
- **Information** – without clear, accurate, simple, relevant and timely information in accessible format, consumers cannot make informed choices
- **Representation** - the right to be heard – find out the views of consumers when developing service standards. If a committee has no consumer representative they might like to consult COPOLCO. National representatives could consult their national consumer organizations.
- **Redress** – deliver effective systems for complaints, feedback, and dispute resolution and to use complaints to drive continual improvement.
- **Sustainability** - - this is to be expanded to include inter alia the Brundtland Report definition of sustainable development: “[development](#) that meets the needs and aspirations of the present without compromising the ability of [future generations](#) to meet their own needs”. Sustainability covers a wide range of issues. As well as reducing impact on water and energy use; reduce waste, use local suppliers and materials to reduce carbon footprint, treat workers fairly and minimize the negative impact on their local communities.

Quality

To be treated as a desirable outcome but not a “right” as such.

Quality is a subjective issue. For example, some consumers would accept lower quality for reasons of price. The key issue is that services should meet or exceed consumer expectations.

KEY ELEMENTS OF SERVICE PROVISION

Service planning and design

- Who is the provider? Subcontractors (responsibilities)
- Who is the customer? (from Guide 15)
- Where is it provided?
- When is it provided
- Consumers need choice, so that they can choose their preferred method of communication.
- How is it provided?
- How is the service explained/communicated?
- Contingency planning (safety or other aspects)

Communication with consumers

- Awareness
- Marketing and advertising
- Commitments and codes of conduct

- Customer contact channels
- Telephone systems
- Website
- Email
- Social media e.g. Facebook, Twitter etc

Contracts and billing

- Clear information
- Help and advice
- Termination of agreement

People/Personnel

Principle established that the person has the competence necessary to perform the task (“how”)

Establish the principle that competence and training have to be addressed but not be prescriptive on how to do it.

- Recruitment of competent staff
- Clear roles and responsibilities
- Training and support

(no technical qualifications)

Provision of information

- Consider Guide 14 revision.
- Accessible formats, available on request, to ensure needs of largest possible number of consumers are met.

All information should be clear, transparent, simple, accurate, and available in an accessible format.

Service environment

- “where” and “how” the service is provided

Feedback and complaints, redress

- Formal process
- Monitoring of complaints and feedback

Continual review/improvement (this is the “quality” mechanism)

- Internal audit
- Monitoring
- Communication between staff and management

- Responsive to feedback – implementing change

Annexes

Simplified checklist/case study of how to apply consumer principles to a specific service industry, at all key stages of services delivery.

Bibliography

EXAMPLES OF SERVICE STANDARD STRUCTURES IN ITALY AND CHINA

Here below some examples of the contents of some service standards/documents developed at Italian national level and in Europe (only one example):

UNI/PdR 1:2012 Beach services (beach resorts)- Safety, quality, accessibility and sustainability requirements of services and amenities

- | | |
|---|--|
| 1. Scope | 6.3 Recreational/welness facilities |
| 2. Terms and definitions | 7. Classification of beach resorts |
| 3. Principle | 8. Resources |
| 4. Objectives, planning and risk analysis | 8.1 Human resources |
| 4.1 Safety | 8.2 Material resources |
| 4.2 Quality | 9. Organization and management |
| 4.3 Usability | 9.1 Service management |
| 4.4 Sustainability | 9.2 Working environment |
| 4.5 Strategic and operative planning | 9.3 Maintenance and cleaning |
| 4.6 Risk analysis | 9.4 Supply |
| 5. Fundamental service requirements | 10. Training of the personnel |
| 5.1 Tourist reception | 11. Measuring, analysis and improvement |
| 5.2 Beach services | Annex A – Checklist of beach resorts facilities/services |
| 5.2.1 Changing rooms | Annex B – Code of conduct |
| 5.2.2 Lifeguard assistance | Annex C – Risk evaluation |
| 5.2.3 Additional bathing services | Annex D – Classification criteria for beach resorts |
| 5.2.4 Beach cleaning | Annex E – Guests satisfaction survey |
| 6. Complementary service requirements | Annex F – Guests expectations survey |
| 6.1 Restaurants facilities | |
| 6.2 Parking and other facilities | |

UNI/PdR 4:2013 Audio-Video and Controls (AVC) integration services - Requirements for design, installation, configuration, calibration, programming and technical verification

- | | |
|--|---|
| 1. Scope | 6.1 AVC integration design |
| 2. Normative references | 6.2 AVC installation |
| 3. Terms and definitions | 6.3 AVC configuration and calibration |
| 4. Principle | 6.4 AVC system programming |
| 5. Service general requirements | 6.5 AVC final technical verification |
| 5.1 Service contract | 6.6 Final delivery to the AVC Client |
| 5.2 Complains management | Annex A – Example of AVC service contract |
| 5.3 Maintenance/upgrading management | ... |
| 6. AVC integration specific service requirements | |

UNI 11402:2011 Financial education of citizens - Service requirements

1. Scope
 2. Normative references
 3. Terms and definitions
 4. Roles and responsibility in the process of financial education
 5. Purpose of financial education, priorities and characteristics
 6. Design of financial education programme
 - 6.1 Definition of objectives
 - 6.2 Identification of contents
 - 6.3 Educational communications: process, methods and tools
 - 6.4 Verification of the results
 7. Delivery of financial education: parties and transparency of purposes
 8. Assessment of results and checking of financial education
- Annex A – Useful examples for the development of content consistent with the lifecycle of individuals

UNI 11584:2015 Collective food services - Minimum requirements to design a menu

1. Scope
2. Normative references
3. Terms and definitions
4. Preliminary elements
 - 4.1 Elements to design the menu
 - 4.2 Menu design for specific diet needs (health problems, cultural and religious needs)
5. Check of the menu
6. Verification of the menu
7. Validation of the menu

UNI 11601:2015 Coaching - Definitions, classification, requirements and service offer

1. Scope
2. Normative references
3. Terms and definitions
4. Coaching service classification
 - 4.1 Contexts
 - 4.2 Typologies
 - 4.3 Results
5. Design and coaching service offer
 - 5.1 Design
 - 5.2 Service offer
 - 5.3 Economical content of the offer
 - 5.4 Terms of contact
6. Service delivery
 - 6.1 Definition of the relation between coach and coachee
 - 6.2 Exploration of the coachee's resources and potentialities
 - 6.3 Definition of objectives and action plan
 - 6.4 Action plan monitoring
 - 6.5 Conclusion of coaching
7. Responsibilities
 - 7.1 Coach responsibilities
 - 7.2 Coachee responsibilities
 - 7.3 Provider responsibilities
 - 7.4 Commitment responsibilities
8. Measuring and evaluation of the service
 - 8.1 Measuring and evaluation of the service provided
 - 8.2 Measuring and evaluation of the results of the service

UNI EN 16636:2015 Pest management services - Requirements and competences

1. Scope
2. Normative references
3. Terms and definitions
4. Professional approach to pest management
5. Process flow of professional service
 - 5.1 Client contact
 - 5.2 Inspect/assess site
 - 5.3 Assess infestation, identify pests and conduct a root cause analysis
 - 5.4 Client and site risk assessment
 - 5.5 Define field of legal application
 - 5.6
6. Competences requirements
 - 6.1 Competence
 - 6.2 Management of equipment
 - 6.3 Supply and use of pesticides
 - 6.4 Documentation and recording
 - 6.5 Insurance
7. Subcontracting
 - Annex A – Required competences
 - Annex B – Field of application of the services
 - ...

Examples on the Structure for Chinese Service Standards

Example 1: GB/T 31725 Specification of education services for 0 to 6 years old children

Contents of National Standards

- 1 Scope
- 2 Normative references
- 3 Terms and definitions
- 4 Service provider
 - 4.1 General
 - 4.2 Service management
 - 4.2.1 Service activities
 - 4.2.2 Human resources
 - 4.2.3 Customer information
 - 4.2.4 Safety and security
 - 4.2.4 Health and hygiene
 - 5 Personnel
 - 5.1 General
 - 5.2 Teaching staff
 - 5.3 Others
 - 6 Environment
 - 6.1 General
 - 6.2 Safety and security
 - 6.3 Environment and hygiene
 - 7 Service facilities
 - 7.1 General
 - 7.2 Safety and security
 - 7.3 Health and hygiene
 - 7.4 Washing and sanitary facilities for infants
 - 7.5 Professional facilities
 - 7.6 Furniture
 - 8 Learning materials
 - 8.1 General
 - 8.2 Safety and security
 - 8.3 Health and hygiene
 - 9 Service delivery
 - 9.1 Providing service information
 - 9.2 Analyzing demand and feature
 - 9.3 Determining Service plan
 - 9.4 Service contract
 - 9.5 Payment
 - 9.6 Delivery
 - 9.7 Effect evaluation
 - 9.8 Communication and feedback
 - 10 Quality evaluation

Example 2: GB/T 30446.2-2013 Psychological counseling Part 2: Services procedures

Contents of National standards

- 1 Scope
- 2 Terms and definitions
- 3 Basic principles
 - 3.1 Voluntary
 - 3.2 Scientific
 - 3.3 Continuous
 - 3.4 Confidential
 - 3.5 Free of restriction
 - 3.6 Ethical
- 4 Appointment and triage
- 5 Delivery
 - 5.1 First visit
 - 5.2 Determining therapeutic plan
 - 5.3 Counseling
 - 5.4 Evaluating effect
- 6 End of service
- 7 Return visit
- 8 Complaints

Example 3: GB/T 27917.2-2011 Express service Part 2: Organization requirements

Contents of National standards

- 1 Scope
- 2 Normative references
- 3 Terms and definitions
- 4 General principles
 - 4.1 Timely
 - 4.2 Accurate
 - 4.3 Secure
 - 4.4 Convenient
- 5 Qualification
 - 5.1 Market access
 - 5.2 Legal person qualification
 - 5.3 Minimum number of employees
 - 5.4 Service capacity
- 6 Corporate culture
 - 6.1 Business philosophy
 - 6.2 Social responsibility
- 7 Franchising management and international business agent
 - 7.1 Franchise management
 - 7.2 International business agent
- 8 Service environment
 - 8.1 Express business place
 - 8.2 Express item processing facility
 - 8.3 International express custom custody
- 9 Equipment and facilities
- 10 Information management
 - 10.1 Functional requirement
 - 10.2 Information recording
- 11 Service format contract
- 12 Safety and security
 - 12.1 General
 - 12.2 Personnel security
 - 12.3 Express item security
 - 12.4 Financial security
 - 12.5 Emergencies
 - 12.6 Others
- 13 Communication
 - 13.1 Communication within the service
 - 13.2 Communication between customer and service provider
- 14 Statistical survey
- 15 Documentation
 - 15.1 Scope
 - 15.2 Management

- 16 Service quality
 - 16.1 Quality management
 - 16.1.1 Specification of service delivery
 - 16.1.2 Service promise
 - 16.1.3 Time limit for service
 - 16.1.4 Payment
 - 16.1.5 Complaint
 - 16.1 Quality evaluation
 - 16.2.1 General
 - 16.2.2 Customer satisfaction
 - 16.2.3 Customer service index
 - 16.3 Service improvement

Example 4: GB/T 27917.3-2011 Express service – Part 3: Service procedures

Contents of National standards

- 1 Scope
- 2 Normative references
- 3 Terms and definitions
- 4 General
 - 4.1 Advanced system
 - 4.2 Strict quality control
 - 4.3 Complete and coordinated information
 - 4.4 Secure delivery
- 5 Domestic express service
 - 5.1 General
 - 5.2 Express item pick-up
 - 5.2.1 Pick-up forms
 - 5.2.2 Door-to-door pick-up
 - 5.2.3 Pick-up at business place
 - 5.2.4 Express item inspection
 - 5.2.5 Encapsulation
 - 5.2.6 Weighing and charging
 - 5.2.7 Fill in express waybill
 - 5.2.8 Record accepting and delivering information
 - 5.3 Internal processing
 - 5.3.1 General
 - 5.3.2 Sorting
 - 5.3.3 Packing and dispatching
 - 5.3.4 Transporting
 - 5.4 Delivery
 - 5.4.1 Forms
 - 5.4.2 Door-to-door delivery
 - 5.4.3 Self-pick-up
 - 5.4.4 Communication between delivery person and customer
 - 5.4.5 Address unknown
 - 5.4.6 Undeliverable express item
 - 5.4.7 Total delay time
 - 5.4.8 Record accepting and delivering information
 - 5.5 Inquiry
 - 5.5.1 Channel
 - 5.5.2 Voucher
 - 5.5.3 Content
 - 5.5.4 Processing time
 - 5.5.5 Time limit for reply
 - 5.5.6 Valid time for inquiry
 - 5.6 Complain and appeal
 - 5.6.1 Complain

- 5.6.2 Appeal
- 5.7 Redress
- 5.8 Exceptions
 - 5.8.1 Redirection
 - 5.8.2 Withdrawal
- 6 International express service
 - 6.1 General
 - 6.2 International exported express
 - 6.2.1 Pick up and deliver
 - 6.2.1.1 General regulations
 - 6.2.1.2 Special regulations
 - 6.2.1.2.1 Order
 - 6.2.1.2.2 Mail inspection
 - 6.2.1.2.3 Weight and price
 - 6.2.1.2.4 Charge
 - 6.2.1.2.5 Fill in express waybill
 - 6.2.2 Sorting, encapsulation and transportation
 - 6.2.3 Customs export declaration
 - 6.2.4 Inquiry
 - 6.2.5 Time limit for total delay
 - 6.2.6 Complain and appeal
 - 6.2.7 Withdrawal
 - 6.2.8 Redress
 - 6.3 International imported express item
 - 6.3.1 Customs import declaration
 - 6.3.2 Sorting and transportation
 - 6.3.3 Delivery
- Appendix A (Normative appendix) Regulations for express item redress
 - A.1 Object
 - A.2 Conditions
 - A.3 Principles
 - A.4 Procedures

Example 5: GB/T 32168-2015 The Online administrative services specifications of administrative services center

Contents of National standards

- 1 Scope
- 2 Normative references
- 3 Terms and definition
- 4 Basic principles
 - 4.1 Transparent
 - 4.2 Secure
 - 4.3 Convenient
 - 4.4 Timely
 - 4.5 Compatible
 - 4.6 Integrated
- 5 Service delivery
 - 5.1 General
 - 5.2 Information disclosure
 - 5.3 Online treatment
 - 5.4 Public interaction
- 6 Safeguard
 - 6.1 Information and system security
 - 6.2 Data recording and management
 - 6.3 Warning
 - 6.4 Multi-channel interaction
 - 6.5 CA digital identification
 - 6.6 Electronic licensing
 - 6.7 Scene service
 - 6.8 Service for special groups
- 7 Evaluation and improvement
 - 7.1 Evaluation method
 - 7.2 Evaluation content
 - 7.3 Evaluation outcome
 - 7.4 Continual improvement



International Organization for Standardization
Organisation internationale de normalisation
Международная организация по стандартизации

AGENDA ITEM 11 KEY AREAS WORKING GROUP



AGENDA ITEM 11 REPORT FROM THE WORKING GROUP ON KEY AREAS FOR CONSUMERS

COPOLCO is invited to: **a)** note/comment on the revised handbook; **b)** note/comment on the revised template for a new submission; **c)** note/comment on the annexes and the new key areas; and **d)** consider the draft resolutions in the light of the report.

1 Convenorship and members

This working group has a twinning convenorship with: Mr Takashi Nakakuki (Japan) and Ms Merete Holmen Murvold (Norway).

The Working group has **41 individual members** representing the following **17 ISO Members**: Australia, Belgium, Canada, Chile, Denmark, France, Germany, India, Italy, Japan, Malaysia, The Netherlands, Republic of Korea, Singapore, Switzerland, The United Kingdom and The United States.

2 Mandate, deliverables and meeting calendar

The Working Group on key areas for consumers operates as a standing committee under the authority of ISO/COPOLCO. It supports the ISO COPOLCO Chair and Secretary by providing information on key areas of work in standardization relevant to consumers, working towards continuous improvement in the delivery of this mandate, while taking account of the needs of developing countries and emerging economies.

Mandate:

- To identify and monitor key areas of standards work in ISO and IEC of interest to consumers including emerging areas, horizontal issues, and mature technical committee work;
- To raise awareness of these areas and disseminate information to the ISO membership, the ISO/COPOLCO members, consumer organizations and consumer representatives, standards development organizations, and members of technical committees and subcommittees;
- To facilitate networking amongst individuals interested in areas of consumer interest.

Deliverables

To publicize its activities, the working group creates four deliverables:

- 1) Handbook
- 2) Project overview
- 3) Report "Standards for consumers – Update"
- 4) List of published consumer standards

Meetings and activities

Since the 2015 Plenary, the working group meeting was held in **November 2015** in conjunction with the Chair's Group and the other working group meetings in Geneva. 7 participants and 11 observers attended the meeting with following items discussed:

- Revision of the Handbook, evaluation of the report format, project overview, update on Key Areas, best practice for Key Persons

Since the November meeting the group has been working on the following activities:

- Revision of the handbook, revision of the template for new key areas, update of the report "Standards for consumers – Update" with input from all the key persons, project overview and potential new key areas.

The next meeting is 15. June 2016 in Geneva.

3 Handbook revision

Following the November discussion, a revised handbook was published on 1st February 2016 for comments among the members and key persons. Significant changes in the handbook were made, adding 3 figures showing the COPOLCO structure, our relation to the other WGs and a figure of the key area setting and monitoring process. The title has been changed to "WG 2 Key areas for Consumers - Handbook". Comments were received from two key persons on the key person's role, so the role is requested for reconsideration accordingly. Please find the updated version of our handbook for consideration and approval. As for the Annex B, it is under revision; please see Clause 5 below.

4 Process for approval of new key areas

During our November meeting, the working group discussed the process of approving new key areas. Today's process for approval at Plenary in May/June will delay updating reports from new consumer standardization work up to one year. Therefore a more dynamic approach is expected and the following process could be introduced.

- 4 week approval amongst the WG 2 members followed by a
- 4 week approval amongst the COPOLCO members

Both approvals will be done by ISO's electronic voting system for traceability and transparency.

5 Updated template for submission

In order for the members of COPOLCO to be able to propose smoothly, without any confusion, a new activity area and/or a new key area, one template has been drafted for consideration and approval. The template is a so-called one merged template, combining the template for a new key area submission and the template for submission of a new activity. Please find the draft revised template as an annex to this report. If the draft is approved, the present template shown in the Annex B in the handbook will be replaced with the revised one.

6 Standards for consumers - Update

Last year's report on key areas was published on ISO's website in February. We have published as a separate document this year's report, "Standards for consumers – Update", based on the valuable reports from our key persons, who are warmly thanked.

7 Project overview

The project overview covers identified key areas of standards work in ISO and IEC of interest to consumers. An overview as per April 2016 is given at annex. During the meeting in June, we will discuss whether the following topics should be added as new key areas:

- Preparations for instruction for use, sustainable cocoa, 3D Printing, e-cigarettes and consumer warranties and guarantees.

Depending on the WG's decision, we would like to ask the Plenary for approval (see draft resolution).

COPOLCO Resolution x/2016

Key areas for consumers (1)

COPOLCO

approves the revised handbook, and
notes the working group's further consideration of the role of key person

COPOLCO Resolution x/2016

Key areas for consumers (2)

COPOLCO

supports the idea of a more dynamic approach for approving a new key area;
approves the new approval process for a new key area.

COPOLCO Resolution x/2016

Key areas for consumers (3)

COPOLCO

approves the revised version of the ISO/COPOLCO Activity Template for use for both new activities and new key area submissions.

COPOLCO Resolution x/2015

Key areas for consumers (4)

COPOLCO

thanks the working group, Key areas for consumers, for its report and annexes,
approves the report "Standards for consumers – Update", and
approves the project overview and proposal to add the following standardization work areas as new key areas: Preparations of instructions for use, sustainable cocoa, 3D Printing, e-cigarettes and consumer warranties and guarantees.

Annexes:

- 1) Comments received on the draft revised Handbook
- 2) Draft revised handbook
- 3) Project overview (April version)
- 4) Template for a new submission
- 5) Standards for consumers – Update 2016 (published separately)



ISO/COPOLCO/WG 2
Key areas for consumers

Email of secretary: mmu@standard.no
Convenorship: JISC (Japan)

Results on the consultation on handbook March 2016

Document type: Other committee document

Date of document: 2016-03-30

Expected action: INFO

Background:

Committee URL: <http://isotc.iso.org/livelink/livelink/open/copolcowg2>

Handbook and figures– Responses on the consultation ending 10 March on WG 2 documents N 103 to N 106

PERSON	ANSWER
Pete Eisenegger	<p>The handbook is most helpful in one way and not in others :-). Overall 'not possible on a voluntary basis' is the message. I am truly sorry to sound so negative but I am being realistic.</p> <p>I've not replied to the whole 'COPOLCO' distribution as I have no idea who that is.</p> <p>Re key person role</p> <p>The verbal brief I was given years ago, and not updated, about a key person was to provide a report each year about what you know is going on and to have my details be made available to others to contact me for views and advice. No one ever contacted me.</p> <p>That covers I guess the first 2 points in the list of key person responsibilities.</p> <p>The overview of my next comments below, which are just at the Key Person level let alone as a convener of a group, is the impractical level of activity and effort being required on a voluntary basis.</p> <p>Across all ICT issues I'd say you are looking at COPOLCO needing 2-3 full time people to organise, provide complementary expertise (especially legal), respond to urgent requests for consumer input on issues from many parties and support reps. I've benchmarked that statement against the extremely tight ship run by ANEC. There is no equivalent ICT support in BSI.</p> <p>Here are the detailed key person responsibilities that I am not covering (as I'm only reporting and acting as an expert source if asked by others) :</p> <ul style="list-style-type: none"> • Co-ordinate and promote consumer activities in the area; <i>In UK my coordinator role is a nominal 12-15 days per year and in practice is more like 20-30 due to a low number of reps and the wide range of ICT issues.</i> <p><i>For COPOLCO and JCT 1 privacy alone that could well involve at least 4-6 sessions each year in key JCT1 SC's SG's and WG's week long meetings plenary and other.</i></p> <ul style="list-style-type: none"> • Raise, where appropriate, any major issue that may require COPOLCO's direct input, with the Key areas for consumers working group; <i>Dealt with as a one off - I'd say that was the gaps report that was ~ 20-25 days work based on UK/EU 100+ days for the privacy guides (only 4 days of which were funded)</i> • Recruit developing countries representatives through their NSB (National Standardization Body), ISO/DEVCO or their international and COPOLCO network if possible; <i>??? global travel, days away from home at meetings, presentations, events</i> • Key persons, with the support of the Key areas for consumers working group, should encourage developing country participation in key areas when opportunities arise. They should also bear in mind the key interests of these

	<p>countries in particular standards, which may well differ from developed countries. It may be necessary to introduce additional aspects to address issues such as climate or culture. Where consumer representatives from developing countries declare an interest in a key area, the key person should take every effort to promote communication; and as a minimum, inform the representative about drafts for comment. This will assist developing country representatives to comment draft standards and to present their views to other participants within the key area. It should be noted that electronic communication is rapidly increasing the opportunities for such information exchange; <i>Electronic comms: Only once a relationship was in place, prior to that this active is team building work with face to face meetings to build a working relationship requiring a fair amount of travel and time away from home.</i></p> <ul style="list-style-type: none"> • Keep Consumers International informed of their activities, particularly at critical stages in standards development when wide consumer support would be valuable. In addition, key persons should be aware that Consumers International would consider placing representatives on technical committees in key areas, assuming funding can be obtained. Consumers International places observers on ISO/IEC technical committees, although its ability to do so is limited as no direct funds are available for them to support this activity. <i>There we have it funding and resources are the key issue</i> <p><i>Note: It is recognized that key persons are volunteers and may have limited resources. Where appropriate, for example, where the work is split into more than one specialist subject or where the workload is high, the key person may share their responsibilities with other participants.</i></p> <p>I guess this is why I'm proposing the priorities and approach in my slides that I am.</p> <p>Also my approach is shaped by the ISO Guides having in practice very limited effectiveness - they were probably the right idea when there were fewer standards and committees but the whole standards landscape is now very diverse and full of silos who don't cooperate and we need a more 21st Century way of getting consumer needs recognised and addressed in standards.</p>
Rae Dulmage	Ok with Handbook.

Summary and the way forward:

Based on the received comments to the Handbook, the COPOLCO secretariat together with the co-chairs will consider the need for revision and further actions.

2016-03-24

**ISO Committee on Consumer Policy
(COPOLCO)**

WG 2 Key areas for Consumers

Handbook

Version 2016-04-27

Table of Contents

	Page
0 Introduction	4
1 About the Key areas for consumers working group	5
1.1 Terms of reference	5
1.2 Cooperation with other COPOLCO working groups	5
2 Process of key areas setting	7
2.1 General	7
2.2 Criteria for setting new key areas	7
2.3 Identifying consumer interests and issues	7
2.4 Process for proposing a new key area and revising or deleting a key area	9
3 Working Group membership, roles and responsibilities	11
3.1 Chair and members	11
3.2 Method of working	11
3.3 Deliverables	11
3.4 Roles and Responsibilities	11
Annex A – Developing Countries	14
Annex B – Template for new key area submissions	15
Annex C – Relevant Publications	17

0 Introduction

This handbook presents ISO/COPOLCO's Key areas for consumers working group, serving as guidance for all involved in its activities.

The working group is a standing committee of COPOLCO. It ensures consumers' perspectives are adequately included in international standards, in line with COPOLCO's strategic objectives.

It identifies key areas of international standardization from the consumers' point of view, recommends COPOLCO approve these, and monitors progress through reports by the key persons it has appointed.

To publicize its activities, the working group creates four deliverables:

- 1) **Handbook**
- 2) **Project overview**
- 3) **Report "Standards for consumers – Update"**
- 4) **List of published consumer standards**

We expect these deliverables to help raise awareness of standards for consumers, improve consumer participation in standardization and support COPOLCO members in their consumer work.

1 About the Key areas for consumers working group

1.1 Terms of reference

Our terms of reference approved by the Chair group in November 2013 read as follows:

The working group Key areas for consumers operates as a standing committee under the authority of ISO/COPOLCO. It supports the ISO COPOLCO Chair and Secretary by providing information on key areas of work in standardization relevant to consumers, working towards continuous improvement in the delivery of this mandate, while taking account of the needs of developing countries and emerging economies.

Mandate:

- To identify and monitor key areas of standards work in ISO and IEC of interest to consumers including emerging areas, horizontal issues, and mature technical committee work;
- To raise awareness of these areas and disseminate information to the ISO membership, the ISO/COPOLCO members, consumer organizations and consumer representatives, standards development organizations, and members of technical committees and subcommittees;
- To facilitate networking amongst individuals interested in areas of consumer concern.

1.2 Cooperation with other COPOLCO working groups

Within COPOLCO, several working groups (WGs) exist besides the Key areas for consumers working group, see figure 1:

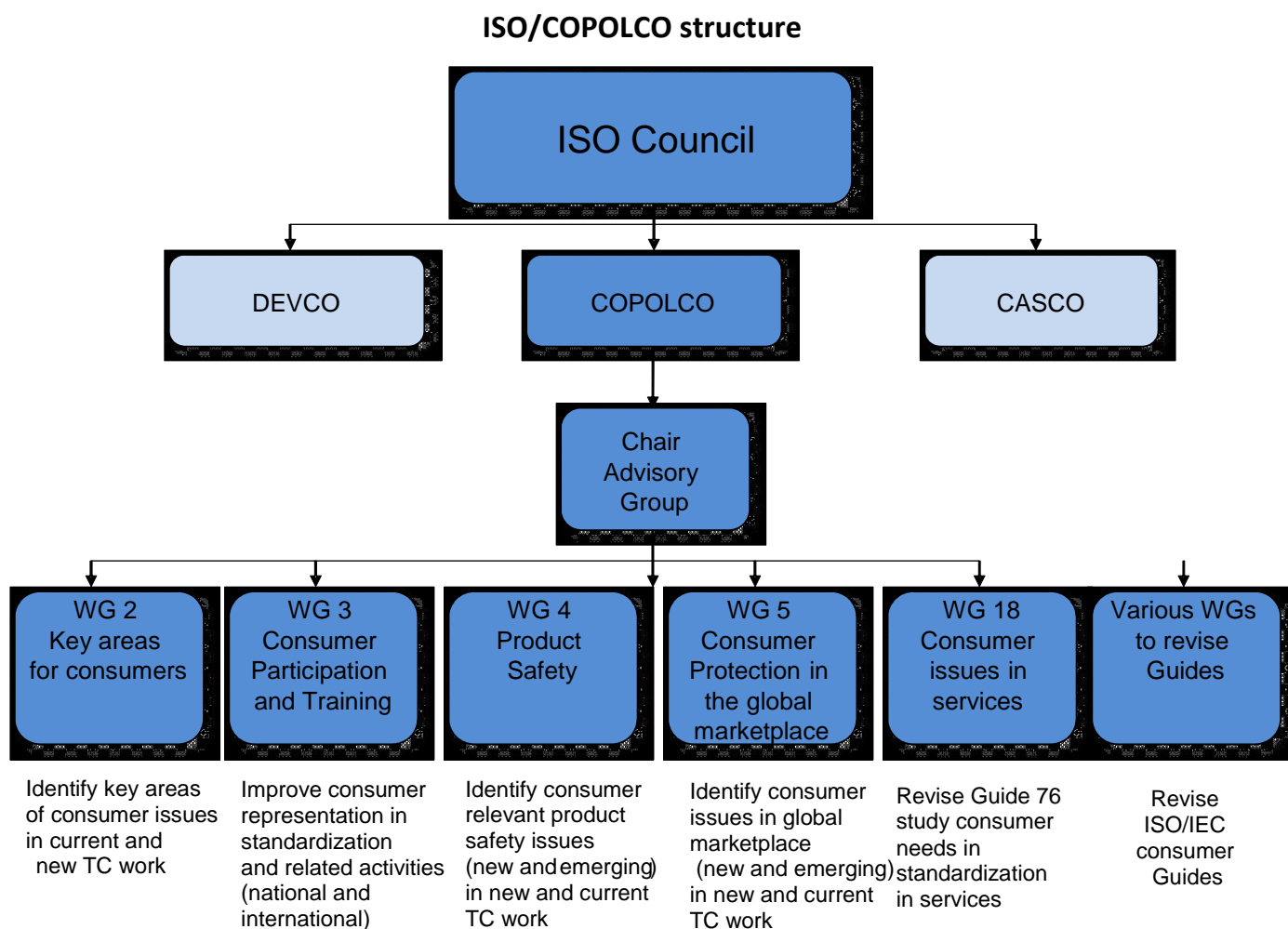

Figure 1 — The ISO/COPOLCO structure

WG 2 on Key areas cooperates with the other working groups in different ways. Below we show briefly the linkage/difference of each working group, to help you understand the this working group’s role within the COPOLCO’s structure:

- **COPOLCO WG 3 on Consumer participation and training** has a mandate to promote awareness of standardization among consumers and consumer organizations and understanding of consumer issues and the value of consumer participation in standardization. It addresses barriers to consumer participation to encourage active participation and develops training and support materials. Their mandate supports consumer participation and understanding consumer issues in already identified key areas.
- **COPOLCO WG 4 on product safety** focuses on consumer product safety in areas not yet registered as key areas. It raises new product safety issues in already notified key areas. It seeks to harmonize international requirements within existing key areas (for example on toys). WG 4 proposes possible new key areas to WG 2.
- **COPOLCO WG 5 on Consumer protection in the global marketplace** develops proposals in the consumer interest for both online and conventional transactions in the global marketplace. It develops new projects, while the Key areas group identifies existing standardization work. When project ideas from WG 5 becomes active standardization work, WG 5 proposes WG 2 add these as new key areas.
- **COPOLCO WG 18 on services** focuses on consumer issues in service standards. It develops Guide 76 (see page 16). WG 2 informs WG 18 on new ISO/IEC activities in services, and WG 18 reports progress of the work.

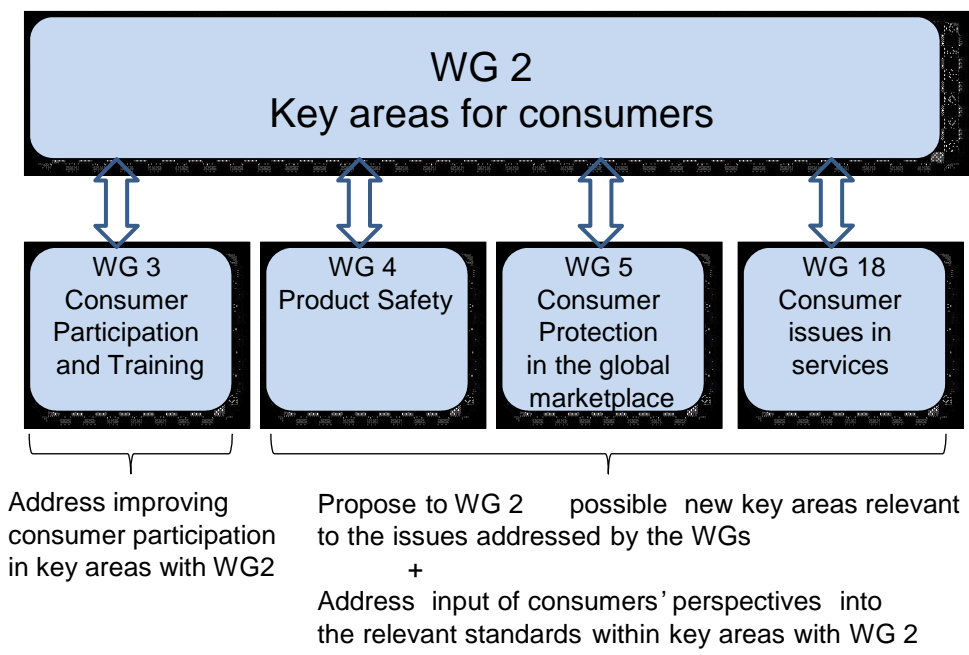

Figure 2 — Relationship between WG 2 and the other WGs

2 Process of key areas setting

2.1 General

A key area is a subject of international standardization relevant for consumers. A key area can be broad and horizontal eg health issues or product safety, or narrow vertical eg unit pricing or cosmetics. To become a key area, it has to be agreed by the WG and approved by COPOLCO members. The process and criteria used for key areas setting follows these guidelines:

- Ensure each area is evaluated according to criteria and a rationale documented for each key area; and,
- Use straightforward and effective mechanisms;
- Include only active work in ISO/IEC, including revision of consumer Guides.

The working group revises key areas during its November meeting for approval by the COPOLCO Plenary in May. Approved key areas serve as a basis for next year's report "Standards for consumers – Update".

There are inherent limitations in identifying and prioritising issues. A process can become inflexible and onerous if used too rigidly and routinely in situations or with issues that are continuously evolving. Key area-setting processes cannot replace evidence, analysis or common sense, judgement or leadership. In addition, it should be recognized that COPOLCO has limited resources for consultation, outreach, and policy research and analysis. Therefore the WG's established process is designed to be both efficient and effective and the criteria based on reasonable and well-established benchmarks for consumer issues.

2.2 Criteria for setting new key areas

To decide if work should be considered key, it must be of sufficient interest to consumers. This section and clause 2.3 provides guidance when considering new key areas:

- Justifying a key area;
- Identifying key consumer issues within it.

The following criteria provide a start to assess issues for consideration by the working group:

- Are there consumer issues/interests in this area of work? (see next section)
- Are these important in terms of numbers of consumers or the degree of seriousness/level of risk involved?
- Do these consumer issues/interests require action at an international level?
- Would international standards help address gaps in consumer protection between developed and developing/transitional economies?

2.3 Identifying consumer interests and issues

The following are examples of relevant issues for consumers:

Safety

What are the hazards and levels of risk? Are they sufficiently serious to warrant inclusion in a Standard? (ISO/IEC Guide 51 provides guidelines for the inclusion of safety aspects in standards).

Performance

Are there consumer issues/interests related to performance that need to be included in a Standard? Consideration should be given to:

- Fitness for purpose;
- Efficiency;
- Durability;
- Maintainability;
- Ease of use;

- Packaging (ISO Guide 41 provides guidelines for the inclusion of consumer requirements in standards for packaging).

Design for all users

Are there consumer issues/interests for all likely users and people who may come into contact with the product or service that need to be included in a Standard? Consideration should be given to all foreseeable uses, including misuse, and the following groups of people:

- Young children (ISO/IEC Guide 50 provides general guidelines on including child safety in standards)
- Older people and persons with disabilities (ISO/IEC Guide 71 assists standards developers in addressing the needs of these consumers).

Information and traceability

Consider the following:

- Are there needs for product marking and/or point-of-sale and/or pre-purchase information, including fitness for purpose, other products or services or hazard warnings needed? (ISO/IEC Guide 14 helps in including product information for consumers in standards).
- Is user information – including instructions for assembly, use, maintenance and disposal – required? (ISO/IEC Guide 37 provides guidance on including instructions for use in standards).
- Description of service(s) (ISO/IEC Guide 76 gives recommendations for addressing consumer issues in service standards).
- Traceability of products.

Choice

Are there requirements in (draft) Standards that will make the product or service unreasonably expensive for any or all likely users? Are requirements design-restrictive?

Sustainability

What are the environmental, economic and social issues? Consider the following:

- Materials and processes of manufacture
- Can materials be recycled?
- Use of products – impact on the environment pollution (air, water, noise, waste); energy efficiency
- Disposal
- Economic issues
- Social and social responsibility issues (see ISO 26000)

Protection of personal data

Are there issues related to privacy and protection of personal data? How can this be addressed by design?

Developed/Developing Countries

Are there consumer issues/interests important for developing countries that differ from or add to those of developed countries? The interests of developing countries in particular standards may differ from developed countries and may require the introduction of additional aspects to address issues such as climate and culture. See also Annex A.

Realistic Requirements and Test Methods

Where (draft) Standards already exist, are the requirements relevant to the product or service under consideration? Is the minimum number of requirements specified to achieve the objective and are they set at appropriate, practical levels? Are there, or will there be, validated test methods to determine conformity to each requirement?

2.4 Process for proposing a new key area and revising or deleting a key area

Step 1 – Submissions

A proposal to add, revise or delete a key area may be made to the Key areas for consumers working group by any COPOLCO member or Consumers International; or by members of the Key areas for consumers working group. Reasons are to be given as to why the subject should be made a key area or why amendment of a key area is necessary; with supporting evidence. To assist submitters for new key areas, a submissions template has been created (Annex B).

Step 2 – Initial scanning and discussion

The Key areas for consumers working group will consider the proposal, by correspondence or meeting, and will decide in principle whether to investigate further. The proposer will be informed of the decision with reasons given if the proposal is rejected.

Step 3 – Evaluation

Once proposals are agreed in principle, the working group will further consider the proposal using objective criteria, as far as is possible. Data provided by the proposer will be assessed along with any further information obtained. The assessment will consider the consumer issues listed above (safety, performance...) and horizontal issues (ie those subjects of broad consumer interest that cut across the work of more than one technical committee, and possibly more than one industry sector).

The resource implications and availability of a key person willing to lead a proposal will also be evaluated. Normally, a proposal will not receive key area status if the position of key person cannot be filled.

In steps 2 or 3, if the proposal is considered out of the scope of the working group (e.g. it is to be a new area of work for ISO/IEC), it will be sent for the Chair's Group consideration.

Step 4 – Recommendations to COPOLCO

After evaluation, the working group will recommend COPOLCO adopt new key areas, revise, or delete existing key areas.

Step 5 – COPOLCO Plenary Approval

If the Plenary approves the revised list of key areas, they will be the basis for the next year reporting from key areas.

Step 6 – Monitoring

Once the key areas are approved by COPOLCO, the working group monitors their progress through reports by key persons (for more detail see the section on roles and responsibilities), and adequate actions will be taken when any concerns are identified. The working group consolidates the reports from the key persons and make them available to the full membership of COPOLCO.

Actions

Possible actions could be:

- Alert COPOLCO members, ANEC, Consumers International and others;
- Raise awareness for the need for consumer representatives (in cooperation with WG 3);
- Raise awareness about concerns in a topic;
- Discuss the issue with other COPOLCO WGs;
- If work is finalized → Delete the key area and add the standard to the "list of consumer standards";
- Recruit additional key person(s);
- Other actions.

Figure 3 shows the key area setting and monitoring process as described above.

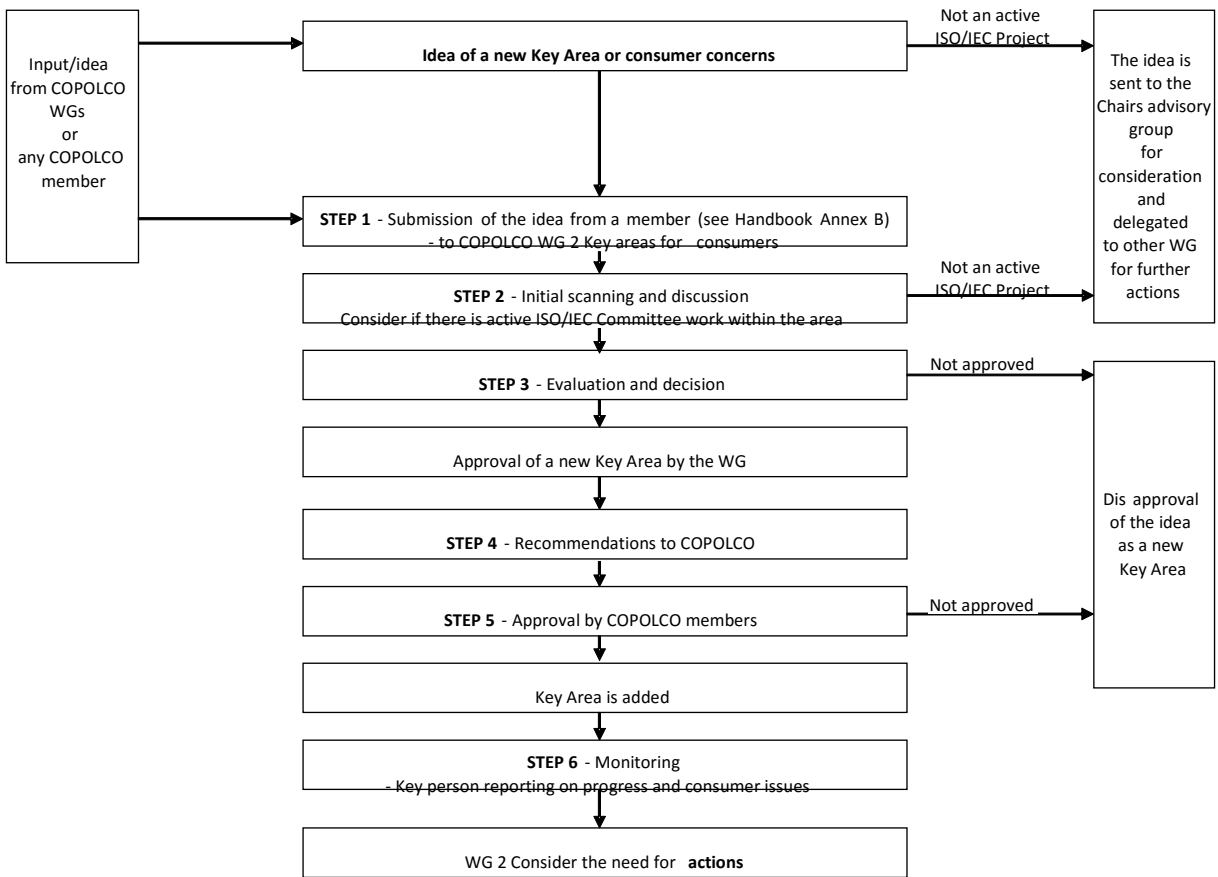

Figure 3 — Key Area setting and monitoring process

3 Working Group membership, roles and responsibilities

3.1 Chair and members

The working group (WG) is led by a Chair, but the COPOLCO Chair can also request a Co-Chair lead or a twinning arrangement with a developing country member. It is supported by ISO/COPOLCO's Secretariat.

Membership is drawn from interested COPOLCO members, including representatives of member bodies and liaisons such as Consumers International. ISO/COPOLCO members from developing countries are particularly encouraged to participate and contribute to the work of the group, to ensure input from all geographic regions and interest groups (see annex A).

All members willing to join the working group need to inform COPOLCO's Secretariat so that experts can be added to ISO's Global Directory. This cannot be done by the National Standardization Body (NSB).

Other participants matter to the success of the key areas, including consumer representatives from national standards bodies or other consumer organizations involved at national or international levels in a COPOLCO key area, for example Consumers International and ANEC.

ISO/COPOLCO has no direct access to ISO technical committees and therefore normally uses its influence to encourage consumer participation in these committees through national standards bodies. However, Consumers International can participate in international standards development in COPOLCO key areas and liaise with relevant ISO technical committees.

3.2 Method of working

WG meetings shall be timed and located to maximize involvement by members' representatives. For example, it will meet in conjunction with COPOLCO's Plenary and Workshop in May/June and meetings of the Chair's Group in October/November. In addition communication shall take place electronically to ensure regular communication between members.

3.3 Deliverables

The WG reports annually to COPOLCO and presents an interim report verbally to the Chairs Group.

In addition to this Handbook, the WG produces a separate **project overview** of all approved key areas. It includes information on who the key person(s) is(are) and notes for example when the key area was approved.

Based on the approved Key Areas the working group collects reports from key persons and produces a report outlining the status of Technical Committee work in the key areas; "**Standards for consumers – Update.**" Produced in March for COPOLCO's Plenary in May/June, it is also published on ISO's Website.

The WG also produces a short **list of published consumer standards**. This contains standards COPOLCO has contributed to. It is also on ISO's Website. Consumer standards developed under a key area deleted because of no activity, can be added to the list of consumer standards (for example ISO 26000). In this way, the key area can easily be added again when revision starts.

To raise awareness of COPOLCO's key areas, the working group also produces a brief communiqué from time to time as new developments occur.

Annex C lists supporting material for the WG.

3.4 Roles and Responsibilities

With the limited resources available, it is important that operations are streamlined and that deliverables are concise and user-friendly. WG success depends on the coordination and cooperation of the various participants involved: Working Group, Chair/Co-Chairs, Secretariat and Key Persons. This section outlines the roles and responsibilities of each.

Working Group

The responsibilities of the **Working Group** and its members include:

- Reporting annually to COPOLCO on key areas of consumer interest;
- Recommending COPOLCO establish processes and criteria for setting and monitoring key areas in the consumer interest;
- Identifying key areas for consumers in both the developed and developing countries;
- Evaluating progress of existing key areas;
- Fostering consumer participation and communication between consumer representatives;
- Contributing to the effective and efficient operation of the Working Group;
- Submit template for possible new key areas;
- Reviewing Working Group deliverables.

Chair/Co-Chairs

The responsibilities of the **Chair/Co-Chairs** include:

- Chairing WG meetings in an effective and consensual way;
- Preparing a draft agenda no later than 4 weeks before the WG meeting;
- Preparing documents for the WG meetings;
- Working with COPOLCO's Secretariat to ensure effective processes;
- Reporting to the Chair's Group;
- Reporting to COPOLCO's Plenary;
- Encouraging ISO members from developing countries to become members of the WG.

Secretariat

The responsibilities of the **Secretariat** include:

- Coordinating the preparation of documents to the COPOLCO Plenary (usually in May), including a collated report of individual progress reports from key persons;
- Providing administrative support to the Working Group, including: arranging meetings, preparing agendas, recording minutes, and sharing information and documents;
- Working with the Chair/Co-Chairs to ensure effective and efficient operation of the Working Group;
- Sharing documents and ISO/IEC new work items in progress (NWIP) related to possible new key areas;
- Encouraging ISO members from developing countries to become members of the WG.

Key Persons

Key Persons are appointed by the Key areas for consumers working group to act as the focal point in agreed key areas. Their primary responsibilities are to:

- **Exchange information** with other consumer representatives interested in the subject area;
- **Report annually to COPOLCO** on matters of consumer interest; activities and progress relevant to international standardization in their key area;
- **Monitor progress** within their area of responsibility and report to the Key areas for consumers working group. No rigid procedure is specified, although key persons will be expected to report against the criteria and should identify any new consumer issues arising during the reporting period.

Progress is to be monitored by the Key Person responsible for the key area as follows:

- Progress of the work within the technical committee(s) through the ISO or IEC project stages;
- Progress in meeting consumer concerns identified at the outset and as the work develops. Work progress monitoring indicates how the committee work is developing, whilst the focus on consumer issues will provide evidence of the success or otherwise in developing international standards which meet consumer needs and evidence of when the key area may be removed as a key area;

- Reporting to the Key areas for consumers working group will normally be annually in January/February, although the Working Group may request a report at any time. A report form will be supplied by the Key areas for consumers working group to assist uniform presentation of reports from all Key Persons;
- Report changes in the scope of ISO/IEC committees, which affects the key areas.

Key Persons are also encouraged to if time allows it to:

- Be directly/closely involved at national or international level in the relevant standards work of the key area;
- Establish, and act as, the focal point for an information network between the consumer representatives;
- Co-ordinate and promote consumer activities in the area;
- Raise, where appropriate, any major issue that may require COPOLCO's direct input, with the Key areas for consumers working group;
- Recruit developing countries representatives through their NSB (National Standardization Body), ISO/DEVCO or their international and COPOLCO network if possible;
- Key persons, with the support of the Key areas for consumers working group, should encourage developing country participation in key areas when opportunities arise. They should also bear in mind the key interests of these countries in particular standards, which may well differ from developed countries. It may be necessary to introduce additional aspects to address issues such as climate or culture. Where consumer representatives from developing countries declare an interest in a key area, the key person should take every effort to promote communication; and as a minimum, inform the representative about drafts for comment. This will assist developing country representatives to comment draft standards and to present their views to other participants within the key area. It should be noted that electronic communication is rapidly increasing the opportunities for such information exchange;
- Keep Consumers International informed of their activities, particularly at critical stages in standards development when wide consumer support would be valuable. In addition, key persons should be aware that Consumers International would consider placing representatives on technical committees in key areas, assuming funding can be obtained. Consumers International places observers on ISO/IEC technical committees, although its ability to do so is limited as no direct funds are available for them to support this activity.

Note: It is recognized that key persons are volunteers and may have limited resources. Where appropriate, for example, where the work is split into more than one specialist subject or where the workload is high, the key person may share their responsibilities with other participants.

Annex A – Developing Countries

The interests of developing countries are critical for international standards development. Developing countries account for over 70% of ISO membership, and are increasing their participation in ISO technical work. Even so, developing country NSBs adopt relatively few international standards and even fewer implement standards effectively. This leads to economic divides and barriers to international trade. The interests of consumers in developing countries are equally important in developing relevant international standards. The Key areas for consumers working group thus welcomes and encourages developing countries representatives involvement in its work and considers developing countries' interests when recommending key areas. Developing country participation in the working group has been encouraged in recent years for both leadership roles and committee membership.

To strengthen this participation, the Key areas for consumers working group recommends developing countries initiate positive dialogue with national consumer organizations to receive their input.

Annex B – Template for new key area submissions

Submission prepared by: _____

1 Description/Nature of the Problem:

- How did the problem come to your attention?
- What is the need and what evidence exists?
- How serious is the problem and what is the level of risk?
- Is this issue a horizontal issue or is it product specific?

2 Can International Standards Address the Problem?

- Does this issue require action at the international level?
- What is the value to society of an international standard – what are the benefits?
- Who would be affected by international standards in this area?
- Are international standards or other ISO/IEC deliverables the appropriate solution?
- Are you aware of relevant national regulations related to this area?
- Is the area being covered by a regional standard (such as an EN standard)?

Note: if the answer to 2 is "no", please go to question 7

3 Can the problem be addressed in an existing Technical Committee or other structure?

See [ISO Technical committees](#)

If yes:

- Is standards work in this area already occurring within an existing Technical Committee(s)?
- Do you think that the problem is adequately addressed in the relevant international standards? If not, in what way, do you think, the standards should address the issue?
- Should there be consumer participation on that committee to raise issues related to this problem?
- Is there a Technical Committee(s) that potentially could address the issue but has not done so?
- What are the reasons why this Technical Committee(s) should address the problem?
- What Technical Committee(s) or other structures should be identified as potentially, or actually, working on the problem?
- Should this be a new key area for COPOLCO (see question 8)?

If no:

- Is this a completely new area of technical work for ISO?
- Should ISO/COPOLCO consider developing a proposal for a new work item proposal for ISO (see question 8)?
- Is there another standardizing organization which is addressing this issue? Which one?

4 Estimate of Time and Resources Required:

How urgent is the need?

What support exists for this area of work? What experts/organizations could contribute?

What would be the impact of resources allocated to this area?

What kinds of resources (time, talent, research, funds, and expertise) are needed?

5 Potential Key Person:

6 What are the consumer interests?

Please identify the consumer interests, such as: safety and health, performance, fitness for

purpose, likely users and usage (eg needs of children, older persons and persons with disabilities), information, choice, protection of the environment, needs of developing countries.

7 Next steps

What do you propose as the next steps for COPOLCO?

- *Monitor the problem by adding it to the list of Key Areas*
- *Conduct a feasibility/justification study*
- *Propose a new area of work for ISO*
- *A specific recommendation for ISO to address the problem*
- *Other _____*

Recommendation by Key Areas WG

Date submitted: _____

Date of initial review: _____

Date of recommendation: _____

Annex C – Relevant Publications

Policy statements

ISO/IEC statement, *Consumer participation in standardization work*
[ISO/IEC/ITU, Policy on Standardization and accessibility](#)

Guides

ISO/IEC Guide 14, *Purchase information on goods and services intended for consumers*
ISO/IEC Guide 37, *Instructions for use of products by consumers*
ISO Guide 41, *Packaging – Recommendations for addressing consumer needs*
ISO/IEC Guide 46, *Comparative testing of consumer products and related services – General principles.*
ISO/IEC Guide 50, *Safety aspects – Guidelines for child safety in standards and other specifications*
ISO/IEC Guide 51, *Safety aspects – Guidelines for their inclusion in standards*
ISO Guide 64, *Guide for addressing environmental issues in product standards*
[ISO/IEC Guide 71, Guide for addressing accessibility in standards](#)
ISO/IEC Guide 74, *Graphical symbols – Technical guidelines for the consideration of consumers' needs*
ISO/IEC Guide 76, *Development of service standards – Recommendations for addressing consumer issues*
ISO Guide 82, *Guidelines for addressing sustainability in standards*

Informative Publications and Resources

[Involving consumers – Why and how: Practical guidance for standards development bodies](#)

[Your voice matters – Why consumers need to participate in standards making ...and how to get involved: 2003](#)

[How ISO/IEC Guides add value to international standards](#)

[The consumer and standards – Guidance and principles for consumer participation in standards development. 2003](#)

[ISO and the consumer](#)

[ISO Directory of consumer interest participation](#)

[Consumers and standards: partnership for a better world](#)

[The international language of graphical symbols eNewsletter: ISO Consumer update](#)



ISO/COPOLCO WG 2 Key areas for consumers PROJECT OVERVIEW 2015 Version 2016-04-25

The Working Group provides information on key areas of ongoing standards work in ISO and IEC of interest to consumers. The following key areas (in alphabetical order) are identified as being very relevant for consumers and where consumers currently are working:

No.	Subject	Reference to ISO/IEC Technical committee(s) Working group(s)	Key Person(s) reporting to COPOLCO, NSB/Liaison	Consumer representative(s) [From ISO GD and key persons report]	Notes
1.	Contact lens care products	ISO/TC 172/SC 7/WG 9 Contact lenses	(To be decided)	Christian de Thuin Xavier Subirana	
2.	Cosmetics – Sun protection	ISO/TC 217 WG 7 Sun protection test methods	(To be decided)	No	
3.	Customer contact centres	ISO/PC 273 Customer contact centres	Mr. Clif Johnston	Gerd Klang (Consumers Association, Sweden) Kristina Unverricht ANEC – Liaison	
4.	E-commerce	ISO/TC 176/SC 3 Supporting technologies/ WG 17 Guidelines for business-to-consumer electronic commerce transactions	Mr. Kernaghan Webb, SCC	Kristina Unverricht	
5.	Elderly & persons with disabilities – Products, services and environment	ISO/TC 173 Assistive products for persons with disability ISO/TC 59/SC 16 Accessibility and usability of the built environment ISO/TC 159 Ergonomics ISO/TC 122 Packaging	Mr. Ken Sagawa, JISC	ISO/TC 159 – Yes (BSI Consumer rep, ANEC and World Blind union) The other TC's - No	

No.	Subject	Reference to ISO/IEC Technical committee(s) Working group(s)	Key Person(s) reporting to COPOLCO, NSB/Liaison	Consumer representative(s) [From ISO GD and key persons report]	Notes
		ISO/IEC JTC 1 Information technology ISO/IEC JTAG (rev Guide 71)			
6.	Environmental issues – labelling, environmental footprint	ISO/TC 207/SC 4 Environmental performance evaluation ISO/TC 207/SC 7 Greenhouse gas management and related activities	Mr. Franz Fiala, ASI Dr. Daegyun Oh, KATS	(No information available)	
7.	Fire safety	ISO/TC 21 Equipment for fire protection and firefighting ISO/TC 38 Textiles ISO/TC 61 Plastics ISO/TC 92 Fire safety ISO/TC 136 Furniture	Mr. Rae Dulmage, SCC Mr. Emmanuel Sopeju, SCC	(No information available)	
8.	Food safety	ISO/TC 34 Food products	Ms. Eunsook Moon, KATS	(No information available)	New key person needed as Ms. Moon is stepping down from this role
9.	Furniture	ISO/TC 136 Furniture	Ms. Benedicte Federspiel, DS Ms. Imola Ferro, NEN	No (not in any WG's)	Children's furniture
10.	Graphical symbols	ISO/TC 145 Graphical symbols ISO/TC 145 / SC 1 Public information symbols ISO/TC 145 / SC 2 Safety identification, signs, shapes, symbols and colours ISO/TC 145 / SC 3 Graphical symbols for use on equipment IEC/SC 3C	Mr. John Perry, BSI	John Perry Susan Woodhouse Gordon Hayward	

No.	Subject	Reference to ISO/IEC Technical committee(s) Working group(s)	Key Person(s) reporting to COPOLCO, NSB/Liaison	Consumer representative(s) [From ISO GD and key persons report]	Notes
		ISO/TC 145-IEC/SC 3 JWG 11 Graphical symbols for use on equipment ISO/IEC Guide 74 Revision Group			
11.	Health informatics	ISO/TC 215 Health informatics	Mr. Rae Dulmage, SCC	(No information available)	
12.	Household appliances (performance)	IEC/TC 59 Performance on household appliances	Ms. Karin Both, DIN	Karin Both G. Heilmann (ANEC) J. Kjeldgaard	
13.	Household appliances (safety) – Electrical accessories and gardening appliances	IEC/TC 61 Safety of household and similar electrical appliances IEC/TC 23 Electrical accessories IEC/TC 34 Lamps and related equipment IEC/TC 35 Primary cells and batteries ISO/TC 86 Refrigeration and air-conditioning	Mr. John Drengenberg, ANSI Mr. Jun Young Choi, KATS	Garcia Fernandez (CI)	
14.	Image safety – Ergonomics of human-system interaction	ISO/TC 159 SC4 Ergonomics of human-system interaction	Mr. Ken Sagawa, JISC,	NCOS (Japan)	
15.	Mechanical contraceptives	ISO/TC 157 Non-systemic contraceptives and STI barrier prophylactics	Mr. Charles Babin, AFNOR (CI participation)	Charles Babin	
16.	Nanotechnology	ISO/TC 229/WG 3 Health, Safety and Environmental Aspects of Nanotechnologies	Ms. Elizabeth Nielsen, SCC Ms. Sue McGinty, BSI	Sue McGinty	Labelling, societal and common issues
17.	Online reputation	ISO/TC 290 Online reputation	Mr. Rémi Reuss, AFNOR	Ratna Devi Nadarajan Julie Hunter Ehud Peleg Michela Vuerich	Added 2014-05-13

No.	Subject	Reference to ISO/IEC Technical committee(s) Working group(s)	Key Person(s) reporting to COPOLCO, NSB/Liaison	Consumer representative(s) [From ISO GD and key persons report]	Notes
18.	Packaging	ISO/TC 122/SC 5 Packaging	Ms. Helen Amundsen, DS	Franz Fiala	Related to child safety. See item 5 above for accessible packaging
19.	Product safety (horizontal issues) – Safety aspects – Guidelines for child safety – Safety aspects – Guidelines for their inclusion in standards	ISO/IEC JWG for the revision of ISO/IEC Guide 50 ISO/IEC JWG for the revision of ISO/IEC Guide 51 ISO/IEC JTAG for the revision of ISO/IEC Guide 71 IEC/TC 59, 61 Performance and safety of household and similar electrical appliances	Ms. Alison Scotland, SA Ms. Eunsook Moon, KATS	Ensook Moon	
20.	Protection of personal data	CEN/TC 225 AIDC technologies CEN/TC 224 Personal identification, electronic signature and cards and their related systems and operations (Standards are published as EN ISO-standards) ISO/IEC/JTC 1/SC 27 IT Security techniques.	Mr. Peter Eisenegger, BSI	Peter Eisenegger	
21.	Road vehicle safety systems	ISO/TC 22/SC 12 + SC 5 Road Vehicles	Ms. Helen Amundsen, DS	Henry Görlitz Mike Hayes	
22.	Road Transport: Safety and Sustainability – Road traffic safety management systems – Electric vehicles	ISO/PC 241 Road traffic safety management systems IEC TC 69 Electric road vehicles and electric industrial trucks	Dr. Kwei Quaye Mr. Peter Glowacki, SCC	TC 241 – Representatives of road safety organizations No	
23.	Safety of toys	ISO/TC 181 Safety of toys	Ms. Helen Amundsen, DS	Helen Amundsen	

No.	Subject	Reference to ISO/IEC Technical committee(s) Working group(s)	Key Person(s) reporting to COPOLCO, NSB/Liaison	Consumer representative(s) [From ISO GD and key persons report]	Notes
				Antonio Bonacruz	
24.	Second hand goods	ISO/PC 245 Cross-border trade of second-hand goods	Mr. Sadie Homer, CI Mr. Rae Dulmage, SCC	Rae Dulmage	
25.	Security	ISO/SAG-S ISO/TC 292 Security	Ms. Norma McCormick, SCC --" Mr. Hyeonho Park, KATS	Norma McCormick	
26.	Services – Energy services	ISO/TC 242/WG 5 Energy services	Mr. Robin Simpson, CI Ms. Jai Ok Kim, KATS		
27.	Services – Financial services – Mobile banking	ISO/TC 68/SC 7 Core banking ISO/TC 68/SC 7 WG 10 Mobile Banking / Payments	Mr. Sri Ram Khanna, BIS Mr. Robin Simpson, CI	No	
				Susan Pandy P.G.L.Potgieser	
28.	Services – Tourism services	ISO/TC 228 Tourism and related services	Mr. Keith Lewis, BSI	Keith Lewis	
29.	Unit pricing	ISO/PC Guidance on unit pricing	Mr. John Furbank, SA	John Furbank	Added 2015-05

New Suggestions for ISO/COPOLCO Activity

Template

Version – Draft 6, 4 April 2016

ISO COPOLCO welcomes all suggestions for topics of consumer concern which might be addressed by International Standardization.

This template allows us to more easily consider these.

It may be that, at this stage, not all aspects are relevant to your proposal. However, the more you complete, the better. If you are unsure or need help, please contact the ISO COPOLCO Secretariat who will assist you.

This will guide you on the information to include.

Please fill Part B if you would like the project to become a new COPOLCO Key Area.

Please submit the template to the ISO COPOLCO Secretariat (Copolco@iso.org).

Thank you



SUGGESTING NEW ISO COPOLCO ACTIVITY - GUIDANCE

A. Complete a pre-submission check to ensure that:

- ✓ All sections of the form are complete as far as practicable.
- ✓ The need for the standard and its benefit to the public interest are fully articulated.
- ✓ Personnel, resources and timeline are shown.
- ✓ Any supporting documentation is attached to the proposal.

B. Seek guidance from the ISO/COPOLCO Secretariat to ensure all sections of the template have been completed to requirements.

C. Submit the completed proposal with all supporting documents by e-mail to the ISO/COPOLCO Secretariat.

TEMPLATE

Part A. New suggestions for COPOLCO activity

1. Proposer's Details

Name:
Email:
Telephone:
Associated National Standards Body (NSB)/Organization:

2. Description of consumer issue

*What is the consumer issue?
What evidence do you have (for example: statistics, consumer detriment)
What is the consumer interest(s), such as: safety and health, performance, fitness for purpose, likely stakeholders (for example children, older persons and persons with disabilities), information, environment, and developing countries?
Does this issue require action at the international level?*

3. Need for an international standard

Why do you think an international standard might be useful in addressing the issue?



4. Benefit to consumers or the public interest

*What is the added value for consumers/public interest of the work?
Check that your proposal fits COPOLCO's terms of reference:*

- *Terms of reference*
 - To study means of helping consumers to benefit from standardization, and means of improving consumer participation in national and international standardization.
 - To provide a forum for the exchange of information on the experience of consumer participation in the development and implementation of standards in the consumer field, and on other questions of interest to consumers in national and international standardization.
 - To advise ISO Council as to the consolidated viewpoints of consumers on matters relevant to ISO's current and potential standardization and conformity assessment work.
 - To advise ISO Council on the need for new or revised policies or actions within ISO as they relate to consumers' needs.

5. Possible existing relevant standards work

Include any existing standards or standards development activity which is – or could be – relevant to the issue, such as:

1. *Are there any relevant national, regional, international standards or ISO/IEC deliverables?*
2. *Are any Technical Committees (TCs) of ISO/IEC already addressing this issue?*
 - 2-1. *If yes, is this issue properly addressed by the TC in your opinion?*
 - 2-2. *If no, how should the TC address the issue?*
3. *Can any Technical Committee of ISO/IEC address this issue?*
 - 3-1. *If so, why should they do so?*
4. *Should there be consumer participation in the TC to raise the issues?*
5. *Is there any other organization besides ISO/IEC which addresses the issue?*
6. *Is there any relevant regulation related to this issue?*

6. Personnel & Resources

If ISO/COPOLCO approves the proposal, would you be able to contribute to the work?

1. *Mention any consumer representatives, technical experts or national standards bodies who you think may wish to be involved.*
2. *What kinds of resources (time, talent, research, funds and expertise) are needed?*

3. Other information



Next steps

What do you propose as the next steps for COPOLCO? For example;

- *Conduct a feasibility/justification study*
- *Prepare a scoping document/paper summarizing the project or project objectives with appropriate references and facts*
- *Propose a new area of work for ISO*
- *A specific recommendation for ISO to address the problem*
- *Monitor the technical work (If you think monitoring is the next step, please go to Part B).*

Recommendation – To be completed by the Chair's Group

Date submitted: _____

Date of initial review: _____

Date of recommendation: _____

Part B. NEW KEY AREA

*Do you wish this suggestion to be considered a new Key Area?
If so, why do you believe this should be added to the list of Key Areas?*

Note: Once the subject is approved as a new Key Area within COPOLCO, monitoring by COPOLCO will start. To become a Key Area, the subject has to be an area of standards work within the ISO/IEC fora and of interest to consumers. In effect, the Key Areas for Consumers WG will propose the Key Areas and Key Persons for decision by COPOLCO.

The Key areas for consumers WG's mandate is, in effect, to inform on key areas of work in standardization relevant to consumers, working towards continuous improvement in the delivery of this mandate, while taking account of the needs of developing countries and emerging economies:

- *To identify and monitor key areas of standards work in ISO and IEC of interest to consumers including emerging areas, horizontal issues, and mature technical committee work;*
- *To raise awareness of these areas and disseminate information to the ISO membership, the ISO/COPOLCO members, consumer organizations and consumer representatives, standards development organizations, and members of technical committees and subcommittees;*
- *To facilitate networking amongst individuals interested in areas of consumer interest.*

Potential Key Person



Recommendation – To be completed by COPOLCO WG 2 Key Areas for consumers

Date submitted: _____

Date of initial review: _____

Date of recommendation: _____



WG 2 KEY AREA FOR CONSUMERS DRAFT AGENDA – MEETING ON 15. JUNE 2016 IN GENEVA

Date/time: 15. June 2016, 14:30-16:00

Place: Geneva – Mövenpick Hotel Geneva, 20 Route de Pré Bois, 1215 Meyrin

Co-Chairs: Mr. Takashi Nakakuki and Ms. Merete Holmen Murvold

Item		Document	Rapporteur
1.	Introductory remarks and adoption of the agenda	N 125	Takashi Nakakuki
2.	For information: Minutes from the November meeting <ul style="list-style-type: none">Follow up actions	N 098	Merete H. Murvold
3.	For approval: Template for new submissions (new key areas)	N 115	Takashi Nakakuki
4.	For approval: WG 2 Handbook	N 114, N 123	Takashi Nakakuki
5.	For approval: New key areas <ul style="list-style-type: none">Instructions for useSustainable cocoaE-cigarettes3D printingConsumer warranties and guaranteesHealthcare administration	N 107 + N 111 N 116 N 117 N 118 N 122 N 124	Merete H. Murvold
6.	For approval: Project overview <ul style="list-style-type: none">Review list of Key areas and Key PersonsOther comments to the project overview?	N 120	Merete H. Murvold
7.	For approval: WG 2 report to the Plenary	N 121	Takashi Nakakuki
8.	For information: Update on potentially new key areas <ul style="list-style-type: none">Bubble technologyWearablesIWA Health servicesRobotics	N 119	Merete H. Murvold Alison Scotland Suzanna Ersoy
9.	For information: “Standards for consumers – Update” <ul style="list-style-type: none">ContentUse of the reportThanks to key persons	N 127	Takashi Nakakuki
10	For information: WG 2 membership	N 126	Merete H. Murvold
11	For approval: Next meeting <ul style="list-style-type: none">Choice of key areas to be presentedPreparation/homework		Merete H. Murvold
12	Any other business		



ISO/COPOLCO/WG 2
Key areas for consumers

Email of secretary: mmu@standard.no
Convenorship: JISC (Japan)

New key area submission Healthcare administration ISO TC 304

Document type: Other committee document

Date of document: 2016-05-11

Expected action: COMM

Action due date: 2016-06-15

Background:

Committee URL: <http://isotc.iso.org/livelink/livelink/open/copolcowg2>

Template for Key Area Submissions

Submission prepared by: ANSI/University of Texas Medical Branch

1 Description/Nature of the Problem:

- *What is the need and what evidence exists?*
- *How serious is the problem and what is the level of risk?*
- *Is this issue a horizontal issue or is it product specific?*

The “back office” or administrative functions of healthcare entities are frequently inefficient and often reflect the least innovative operations within these organizations. This circumstance causes administrative support, rather than the clinical services that patients require, to be on average 2/3rds of the cost of all care. We have also discovered from discussions with international health care providers that, regardless the mechanism for providing care and the types of clinical treatments that patients receive, administrative inefficiencies and ineffectiveness establish burdens for caregivers as well. This issue is horizontal in nature since it includes all types of healthcare providers and all administrative functions within healthcare (i.e., supply chain, IT, Admissions, HR, finance, etc.)

2 How Problem Came to Your Attention:

As a major academic health system in the United States, UTMB has discovered this problem through available research, decades of experience, and discussions with our global industry partners.

3 Can International Standards Address the Problem?

- *Does this issue require action at the international level?*
- *What is the value to society of an international standard – what are the benefits?*
- *Who would be affected by international standards in this area?*
- *Are international standards or other ISO/IEC deliverables the appropriate solution?*
- *Are you aware of relevant national regulations related to this area?*
- *Is the area being covered by a regional standard (such as an EN standard)?*

Note: if the answer to 3 is "no", please go to question 8

Since this problem is not limited to any particular geographic region, robust healthcare administration is an area of technical inquiry that avails itself to global solutions. International standards will codify the most effective metrics and practices for improving the delivery of administrative support to healthcare entities.

Stakeholders who will benefit from this standard include:

- Patients and other direct consumers of healthcare will benefit from slower increases in the cost of health care and an anticipated improvement in access to care. UK and US research also shows that patients are more satisfied with their care experience and are healthier after receiving clinical services from better managed healthcare organizations.
- Organizations that provide healthcare benefits will enjoy either a reduction in their

benefits costs or more predictable, slower increases in the costs of coverage as efficiencies in healthcare management are transferred to the policy holders.

- Insurance companies and national Ministries of Health will more accurately monitor and compare the quality of management and assess cost control as they determine which healthcare entity provides the best value for their customers and populations.
- Developing countries and rural healthcare providers will more easily access and adopt the interoperable practices and metrics of more established and better resourced healthcare systems.
- Healthcare entities will enjoy the sharing of effective management practices that will drive better outcomes for patients and will reduce the increase in spending of non-clinical services.
- Society in general will be better informed about the effectiveness of their healthcare system and gain access to a better quality of care.

We are not aware of any Regional or ISO/IEC standards that address the administrative support of care delivery across the globe. The degree to which national Health Ministries involve themselves in healthcare administration vary notably by country. Based on our review of known administrative practices and metrics, Health Ministry involvement among nations is not systematic, transferable, interoperable or comparable.

4 Can the problem be addressed in an existing Technical Committee or other structure?

If yes:

- *Is standards work in this area already occurring within an existing Technical Committee(s)?*
- *Should there be consumer participation on that committee to raise issues related to this problem?*
- *Is there an international Technical Committee(s) that potentially could address the issue but has not done so?*
- *What are the reasons why this Technical Committee (s) should address the problem?*
- *What Technical Committee(s) or other structures should be identified as potentially, or actually, working on the problem?*
- *Should this be a new key area for COPOLCO (see question 8)?*

If no:

- *Is this a completely new area of technical work for ISO?*
- *Should ISO/COPOLCO consider developing a proposal for a new work item proposal for ISO (see question 8)?*
- *Is there another standardizing organization which is addressing this issue? Which one?*

Although there are Technical Committees (TCs) and other standards developing organizations that exist in the general healthcare space, none have a singular or direct role to improve the operations of the administrative support of these entities.

The new TC will actively seek opportunities to coordinate and liaison with all of the international organizations below. Some of these international organizations have self-described management standards. These standards are small in number and mostly focus on leadership effectiveness, accounting, safety, quality, and performance management

practices. These standards frequently support an existing conformity assessment schema. Instead of standards, some organizations below provide checklists, guidelines and other tools to help improve healthcare entity management.

Multilateral Organizations:

United Nations (UN)

World Health Organization (WHO)

Pan American Health Organization (PAHO)

UN Economic and Social Council (UNESCO)

The United Nation Children’s Fund (UNICEF)

United Nations Development Program (UNDP)

World Bank and WHO Special Program for Research and Training in Tropical Diseases

International Labour Organization (ILO) has a standard for labour management which will not conflict with the work of this committee.

Bilateral Agencies:

United States Agency for International Development (USAID)

Non-Governmental Organizations:

Project Hope (USA)

Oxfam International (UK)

Refugee and Disaster Relief Organizations:

International Red Cross Red Crescent Movement

***Medecins san Frontieres* (MSF)**

The new Technical Committee will actively seek opportunities to coordinate and liaison with all of the internal parties below. The new TC’s scope prohibits standards development for clinical care or medical devices. Therefore the new standards will be complementary, mutually reinforcing documents. The TC will have an opportunity to normatively reference standards from the committees below.

ISO/IEC Technical Committees:

ISO/TC 106 Dentistry

ISO/TC 168 Prosthetics and orthotics

ISO/TC 170 Surgical instruments

ISO/TC 176 Quality management and quality assurance

ISO/TC 194 Biological and clinical evaluation of medical devices

ISO/TC 198 Sterilization of health care products

ISO/TC 210 Quality management and corresponding general aspects for medical devices

ISO/TC 215 Health informatics

ISO/TC 249 Traditional Chinese medicine

ISO/TC 251 Asset management

ISO/TC 260 Human resource management
ISO/TC 262 Risk management
ISO/TC 267 Facilities management
ISO/TC 276 Biotechnology
ISO/PC 277 Sustainable procurement
ISO/PC 283 Occupational health and safety management systems

Other

ISO/COPOLCO

ISO/TC 304 for Healthcare Administration welcomes ISO/COPOLCO's involvement in this standards setting effort. We look forward to any NWIP or other ideas and guidance that they might offer the TC.

5 Estimate of Time and Resources Required:

How urgent is the need?

What support exists for this area of work? What experts/organizations could contribute?

What would be the impact of resources allocated to this area?

What kind of resources (time, talent, research, funds, and expertise) are needed?

Since the quality and availability of care is crucially affected by the effectiveness of healthcare administration, the need is current and urgent. We have received very positive feedback about ISO/TC 304 from national representatives from the following countries: Argentina , Austria , Italy , Japan , Korea, Republic of Korea, the Netherlands , Senegal , Switzerland , United Kingdom, Australia , Belgium, Czech Republic , Finland , France, Hungary , India , Iran, Islamic Republic of , Israel , Norway, Poland , Portugal , Serbia , Slovakia , Spain, Sweden , Thailand , and the United Arab Emirates.

We have also reached out the World Health Organization and other global healthcare organizations for their feedback and support of this effort.

As with most standards setting efforts, the involvement national experts and the availability of material support is essential to maintain standards development operations. UTMB will provide material and administrative support, but we expect the bulk of the participation and financial assistance to come from private and public participants and grants and sponsorships from materially interested parties.

Although we are seeing a significant interest in this endeavour, we will refrain from specifying the exact resource needs until we have determined the numbers and expertise of those who will participate and priority, complexity, number, and type of the NWIPs that will be pursued.

6 Potential Key Person:

Ronald B. McKinley, PhD, MBA, SPHR
Vice President
Human Resources and Employee Services
Chief Human Resources Officer
Associate Professor (Adj.)
Preventive Medicine & Community Health
Chair

US TAG ISO TC/260 Human Resource Management

The University of Texas Medical Branch at Galveston
301 University Blvd., Galveston, TX 77555-0139
P 409.772.2636 M 409-539-0277
F 409.772.8698 E rbmckinl@utmb.edu

7 What are the consumer interests?

Please identify the consumer interests, such as: safety and health, performance, fitness for purpose, likely users and usage (e.g., needs of children, older persons and persons with disabilities), information, choice, protection of the environment, needs of developing countries.

Patients and other direct consumers of healthcare will benefit from slower increases in the cost of health care and an anticipated improvement in access to care. UK and US research also shows that patients are more satisfied with their care experience and are healthier after receiving clinical services from better managed healthcare organizations. Developing countries and rural healthcare providers will more easily access and adopt the most effective practices and metrics of more established and better resourced healthcare systems.

8 Next steps

What do you propose as the next steps for COPOLCO?

- *Monitor the problem by adding it to the list of key areas*
- *Conduct a feasibility/justification study*
- *Propose a new area of work for ISO*
- *A specific recommendation for ISO to address the problem*
- *Other _____*

We hope that COPOLCO will participate in the development of these standards. At minimum we welcome their NWIP submissions. We look forward to liaising with COPOLCO so that consumer interests in healthcare delivery are forcefully advocated during the development and deployment of these standards.

Recommendation by Key Areas WG

**Draft recommendation to be decided 2016-06-15:
COPOLCO WG 2 Key areas for consumers approves to add "Healthcare administration" as a new key area and appoints Mr. Ronald B. McKinley as the key person.**

Date submitted: ___ 2016-05-10 _____

Date of initial review: ___ 2016-05-11 _____

Date of recommendation: _____



ISO/COPOLCO/WG 2
Key areas for consumers

Email of secretary: mmu@standard.no
Convenorship: JISC (Japan)

New key area submission - Robotics ISO TC 299 and ISO TC 199 WG 12

Document type: Other committee document

Date of document: 2016-05-24

Expected action: COMM

Action due date: 2016-06-15

Background:

Committee URL: <http://isotc.iso.org/livelink/livelink/open/copolcowg2>

Template for Key Area Submissions

Submission prepared by: Brian Tranter, Consumer representative BSI

1 Description/Nature of the Problem:

- *What is the need and what evidence exists?*
- *How serious is the problem and what is the level of risk?*
- *Is this issue a horizontal issue or is it product specific?*

A generation of machines is now being designed and built that have the potential to change lives. Generally referred to as robots or robotic systems what separates these machines from all the others is that they are to some extent autonomous. Such machines are not new as industry has used robots for many years. But developments in computing and manufacturing make it feasible to incorporate autonomy into almost any machine and also allows for the development of specific robots that will be used with / and by ordinary consumers.

The potential applications for autonomous or semi-autonomous machines are almost boundless, which is very positive for the consumer. However, autonomy brings with it issues that have not previously been addressed. Questions of safety, privacy, testing, ethics etc.. all arise that are particular to machines that make decisions without human intervention.

Although this may appear to be product specific, the variation of what may be considered a robot and the range of issues to be addressed makes this horizontal

The potential risks are significant and limited only by any constraints on the applications to which robots are applied.

2 How Problem Came to Your Attention:

Background in advanced engineering, personal contacts with roboticists and membership of UK / ISO standards committees involved in robotics

3 Can International Standards Address the Problem?

- *Does this issue require action at the international level?*
- *What is the value to society of an international standard – what are the benefits?*
- *Who would be affected by international standards in this area?*
- *Are international standards or other ISO/IEC deliverables the appropriate solution?*
- *Are you aware of relevant national regulations related to this area?*
- *Is the area being covered by a regional standard (such as an EN standard)?*

Note: if the answer to 3 is "no", please go to question 8

Yes.

Robotics is international and requires international interventions

International standards have the potential to open up new and useful applications to robots while at the same time helping to maintain acceptable performance levels, safety limits and other consumer critical parameters

Designers, manufacturers, installers and integrators of robot technology would all be directly affected by any international standards. Consumers would also be affected both directly and indirectly.

International standards would be part of the solution to the issues raised. IEC and ISO should be involved as robots are electromechanical machines.

Robots are all machines in some sense and hence covered by many existing national regulations. Autonomy and how it should be dealt with is however as far as I am aware generally not covered. (For example consider the case of a robot car. Cars are extensively regulated but regulators are struggling to keep up with autonomy, even limited autonomy in cars).

The only national standard I am aware of is BS 8611 'Robots and robotic devices - Guide to the ethical design and application of robots and robotic systems'. I am not aware of any EN standards either published or being developed independent of ISO or IEC

4 Can the problem be addressed in an existing Technical Committee or other structure?

If yes:

- *Is standards work in this area already occurring within an existing Technical Committee(s)?*
- *Should there be consumer participation on that committee to raise issues related to this problem?*
- *Is there an international Technical Committee(s) that potentially could address the issue but has not done so?*
- *What are the reasons why this Technical Committee (s) should address the problem?*
- *What Technical Committee(s) or other structures should be identified as potentially, or actually, working on the problem?*
- *Should this be a new key area for COPOLCO (see question 8)?*

If no:

- *Is this a completely new area of technical work for ISO?*
- *Should ISO/COPOLCO consider developing a proposal for a new work item proposal for ISO (see question 8)?*
- *Is there another standardizing organization which is addressing this issue? Which one?*

Yes.

ISO/TC 299 'Robotics' was created in 2015. Previous robotics work was carried out by a subcommittee of ISO/TC 184 'Automation systems and integration'. This change reflects the growing importance of robotics and how it has developed well beyond a branch of automation.

ISO/TC 199 'Safety of machines' has recognized the need for new safety standards in the field of autonomous machines. A new working group WG12

'Human machine interactions' is being set up and the first meeting is expected at the end of June.

It is essential that consumers are represented in these committees as many applications of robots directly involve them. The creation of TC/199 WG12 was the result of a study group led by me, a consumer representative. The first project, a new standard on human machine physical interactions will also be led by me, a consumer representative.

5 Estimate of Time and Resources Required:

How urgent is the need?

What support exists for this area of work? What experts/organizations could contribute?

What would be the impact of resources allocated to this area?

What kind of resources (time, talent, research, funds, and expertise) are needed?

The need for standards is current and requires immediate action

Research groups, social and welfare services, legal experts....

6 Potential Key Person:

Brian Tranter

7 What are the consumer interests?

Please identify the consumer interests, such as: safety and health, performance, fitness for purpose, likely users and usage (e.g., needs of children, older persons and persons with disabilities), information, choice, protection of the environment, needs of developing countries.

Safe and ethical use of autonomous machines. This is applicable to all consumers with special attention to the impact on children.

Universal design: Consumers who are disabled, infirm or need physical assistance as they are more likely to make use robots in the future. Populations that are aging.

Performance levels, safety limits, ease of use, easy to do maintenance.

8 Next steps

What do you propose as the next steps for COPOLCO?

- *Monitor the problem by adding it to the list of key areas*
- *Conduct a feasibility/justification study*
- *Propose a new area of work for ISO*
- *A specific recommendation for ISO to address the problem*
- *Other _____*

Standards work is already being pursued but more could be done. Greater co-

operation between ISO and IEC would be beneficial.

COPOLCO could help by raising the profile of this activity to increase consumer participation. I have not met any other consumer representatives involved in this area of standards work

Recommendation by Key Areas WG

DRAFT RESOLUTION:

“COPOLCO WG 2 Key areas for consumers approves to add "Robotics" as a new key area and appoints consumer representative Mr. Brian Tranter from BSI as the key person. We thank Mr. Tranter for his willingness to report from the work in ISO/TC 299 and ISO/TC 199 WG 12”

Date submitted: 2016-05-18

Date of initial review: 2016-05-24

Date of recommendation: _____



Standards for consumers – Update

2016

**ISO Committee on Consumer policy
(COPOLCO)**

(Page intentionally left blank)

Table of contents

1.	Contact lens care products.....	7
2.	Cosmetics	9
3.	Customer Contact Centres.....	11
4.	Customer Satisfaction	13
5.	E-Commerce.....	15
6.	Elderly and Persons with Disabilities.....	17
7.	Environmental Issues.....	21
8.	Fire Safety.....	23
9.	Food Safety.....	27
10.	Furniture	31
11.	Graphical Symbols.....	33
12.	Health Informatics	39
13.	Household Appliances (performance)	47
14.	Household Appliances (safety).....	53
15.	Image Safety.....	57
16.	Mechanical contraceptives.....	59
17.	Nanotechnology	63
18.	Online reputation.....	67
19.	Packaging	69
20.	Product Safety (horizontal Issues).....	71
21.	Protection of Personal Data	79
22.	Road Vehicle Safety Systems	85
23.	Road Transport.....	89
24.	Safety of Toys	95
25.	Second-hand Goods	97
26.	Security.....	99
27.	Services – Energy Services	105
28.	Services – Financial services (mobile banking and payments).....	107
29.	Services – Tourism Services.....	109
30.	Unit pricing.....	113

(Page intentionally left blank)

Foreword

Working Group WG 2 "Key areas for consumers" is a standing committee of ISO/COPOLCO. It supports members by identifying, monitoring and informing on key standards work of interest to consumers within ISO and IEC.

This report

- summarizes the latest standardization work identified by the working group;
- points out the specific consumer issues in the work;
- informs on the presence of consumer representative(s).

key persons are responsible for reporting on the specific work collected in this report. This report is updated as per January-March 2016.

A special thanks to the key persons for their effort in making this annual status available.

(Page intentionally left blank)

1. Contact lens care products

1.1. Summary

The scope of ISO/TC 172 covers standardization of terminology, requirements, interfaces and test methods in the field of optics and photonics. In ISO/TC 172/SC 7, there is a working group WG 9 Contact lenses which is relevant for consumers.

1.2. Standards work

The following standards on contact lenses are under development in ISO/TC 172/SC 7:

- ISO/AWI 19979, Ophthalmic optics – Contact lenses – Hygienic management of multipatient use trial contact lenses
- ISO/DIS 18369-1, Ophthalmic optics – Contact lenses – Part 1: Vocabulary, classification system and recommendations for labelling specifications
- ISO/DIS 18369-2, Ophthalmic optics – Contact lenses – Part 2: Tolerances
- ISO/DIS 18369-3, Ophthalmic optics – Contact lenses – Part 3: Measurement methods
- ISO/DIS 18369-4, Ophthalmic optics – Contact lenses – Part 4: Physicochemical properties of contact lens materials
- ISO 18189, Ophthalmic optics – Contact lenses and contact lens care products – Cytotoxicity testing of contact lenses in combination with lens care solution to evaluate lens-solution interactions
- ISO/NP 11981, Ophthalmic optics – Contact lenses and contact lens care products – Determination of physical compatibility of contact lens care products with contact lenses

1.3. Relevant links

[ISO/TC 172 Optics and photonics homepage](#)

1.4. Date of information and meetings

No information available.

1.5. Key person

Key person is being sought.

(Page intentionally left blank)

2. Cosmetics

2.1. Summary

The scope of ISO/TC 217 Cosmetics covers standardization in the field of cosmetic products. Standards in working group 7, Sun protection test methods, is relevant for consumers.

2.2. Standards work

The following standard is under development:

- ISO/AWI 16217 Cosmetics – Sun protection test methods – Water resistance – water immersion procedure

2.3. Relevant links

[ISO/TC 217 Cosmetics homepage](#)

2.4. Date of information and meetings

No information available.

2.5. Key person

Key person is being sought.

(Page intentionally left blank)

3. Customer Contact Centres

3.1. Summary

This project was first suggested during the COPOLCO 2009 New Delhi meeting, where it was noted;

- customer contact centres are often a source of frustration to consumers;
- organizations increasingly outsource their services to call centres, often across national boundaries, which adds to the complexity; and,
- standards addressing these issues from a quality management perspective were being developed in Europe, South Africa, and possibly other countries and regions.

In view of the international nature of outsourced call centre operations, COPOLCO resolved to research the matter in greater depth (COPOLCO Resolution 12/2009). After a lengthy investigation COPOLCO agreed at its 2011 London meeting to forward a New Work Item Proposal to ISO Council for further processing, and the project was finally approved in 2012. Meetings of the Project Committee (PC) were held in July 2013 (Vienna), February 2014 (Kuala Lumpur), December 2014 (Madrid) and February 2016 (Vienna).

At the PC's inaugural meeting, consumer concerns were raised that the outcome would be a management system standard focusing on the relationship between a contact centre and the organization(s) employing its services without any direct consideration of consumer requirements. It was agreed to address these concerns by dividing the standard into two parts, the first taking the form of a service (as opposed to a management system) standard, and the second indicating consumer requirements to be specified in the contractual relationship between the contact centre and the organization(s) employing its services.

The remaining consumer concerns are to preserve the distinction between the two parts of the standard and to ensure that the business interests present in the PC do not succeed in watering down the consumer requirements in the second part to an extent that renders them meaningless.

3.2. Standards work

Committee	WG / Standard(s) affected	Issue addressed / Progress or change reported
ISO/PC 273 <i>Customer Contact Centres</i>	ISO CD 18295-1, <i>Customer Contact Centres – Requirements for Service Organizations</i>	CD accepted subject to editing. DIS to be issued by 2016-04-01
ISO/PC 273 <i>Customer Contact Centres</i>	ISO CD 18295-2, <i>Customer Contact Centres – Requirements for Organizations employing the services of Customer Contact Centres</i>	Minor change to title agreed. CD accepted subject to editing. DIS to be issued by 2016-04-01

3.3. Relevant links

[ISO/PC273 Home Page](#)

3.4. Date of information and meetings

Committee	Date of last meeting	Date of next meeting	WG/Standard(s)	Consumer representative(s) (Name, organisation/affiliation) involved in the key areas
ISO/PC273 <i>Customer Contact Centres</i>	2016/02/01-05 Austria	2016/10/03-07 South Africa		Gerd Klang, Consumers Association, Sweden Kristina Unverricht, DIN ANEC – Liaison

3.5. Key person

For further information, please contact: Clif Johnston, johnston.clif@gmail.com, South African National Consumer Union (SANCU)

4. Customer Satisfaction

4.1. Summary

These standards have been published and the subject area is mature. Below is a summary of information and resources:

Customer satisfaction and complaints handling

ISO 10001:2007 Quality management - Customer satisfaction - Guidelines for codes of conduct for organizations

[Read an abstract of ISO 10001 here](#)

ISO 10002:2004 Quality management - Customer satisfaction - Guidelines for complaints handling in organizations

[Read an abstract of ISO 10002 here](#)

ISO 10003:2007 Quality management - Customer satisfaction - Guidelines for dispute resolution external to organizations

[Read an abstract of ISO 10003 here](#)

ISO 10004:2012 Quality management - Customer satisfaction - Guidelines for monitoring and measuring

[Read an abstract of ISO 10004 here](#)

Read the article [Measuring customer satisfaction with new ISO Technical Specification](#)

ISO 10008:2013 Quality management - Customer satisfaction - Guidelines for business-to-consumer electronic commerce transactions

[Read an abstract of ISO 10008 here](#)

The standards on customer satisfaction and complaints handling were developed in [ISO/TC 176](#).

(Page intentionally left blank)

5. E-Commerce

5.1. Summary

This standards have been published and the subject area is mature. Below is a summary of information and resources:

ISO 10008:2013 Quality management - Customer satisfaction - Guidelines for business-to-consumer electronic commerce transactions

[Read an abstract of ISO 10008 here](#)

The standards on customer satisfaction and complaints handling were developed in [ISO/TC 176](#).

5.2. Key person

For further information, please contact: Kernaghan Webb, kernaghan.webb@ryerson.ca, Chair, ISO 10008 WG; Dept. of Law and Business, Ryerson University, Toronto, Canada.

(Page intentionally left blank)

6. Elderly and Persons with Disabilities

6.1. Summary

Older persons and persons with disabilities have various types of difficulties in using consumer products due to their limitation of human abilities, i.e. hard of seeing, hard of hearing etc. These problems could be solved by means of designing standards which account for the needs and limited abilities of older persons and persons with disabilities.

This concept was addressed in ISO/IEC Guide 71:2001 under the name of accessibility or accessible design, with work initiated by COPOLCO around the year 2000. Consumers have been keen on progress on how this guide is being implemented in every product and how consumer voices are reflected in the design of everyday products.

In December 2014, ISO/IEC Guide 71 was revised and published with new information and practices collected so far. Again this revision was initiated by COPOLCO.

2015 was a starting point of developing standards and implementing the concept of accessibility elaborated in the new Guide 71:2014. Activities were done continuously and new movements were seen for the well-being of aged people (health care, active life, etc.) both in ISO and IEC; all of which are expected to expand further in 2016.

6.2. Standards Work

Committee	Working draft or standards	Progress or change during reporting year Any action to be taken
ISO/TC159/WG2 Ergonomics for people with special requirements	TR 22411 2nd edition Ergonomics data and guidelines for use for the application of ISO/IEC Guide 71:2014	Human data relevant for accessibility is being collected. The work is ongoing.
ISO/TC159/SC4 Ergonomics of human system interaction/ WG10 Accessible design for consumer products	AWI 24507 Ergonomics – Accessible design – Doors and handles of consumer products AWI 21054 Ergonomics – Accessible design – Input controls for consumer products AWI 21056 Ergonomics – Accessible design – Guidelines for designing tactile symbols and letters. PWI 24506 Ergonomics - Accessible design –Indicator lamps on consumer products.	Accessibility of doors and handles of consumer products are being developed. The CD ballot will be done in 2016. Accessibility of signage and manipulation of input controls of consumer products are being developed. Guidelines on designing legible tactile symbols and letters are being developed. The CD ballot will be done in 2016. Accessibility of indicator lamps are being prepared for a NWIP.

<p>ISO/TC159/SC5 Ergonomics of the physical environment/ WG5 Physical environment for people with special requirements</p>	<p>ISO/ 24505 Ergonomics – Accessible design – Method for creating colour combination taking account of age-related change in human colour vision</p>	<p>A method for colour combination for older people was developed. FDIS was approved and the standard is to be published in 2016. Similar standards for colour defects and low vision are being planned.</p>
<p>ISO/TC173/SC7 Accessible design/WG3, WG4, WG5, WG6</p>	<p>ISO/19026 Accessible design – Shape and colour of a flushing button and a call button, and their arrangement with a paper dispenser installed on the wall in public restroom</p> <p>ISO/19027 Accessible design – Design principles for communication support board using pictorial symbols</p> <p>ISO/19028 Accessible design – Information contents, figuration and display methods of tactile guide maps</p> <p>ISO/19028 Accessible design – Auditory guiding signals in public facilities</p>	<p>Design and arrangement of toilet equipment etc. was standardized. Published in 2015.</p> <p>Basic design method for pictorial symbols for communication was standardized. Published in 2016.</p> <p>Design requirements for tactile guide maps were standardized. Published in 2016.</p> <p>Design requirements for auditory guiding signals were standardized. Published in 2016.</p>
<p>ISO/TC122 Packaging /WG9 Accessible design for packaging</p>	<p>ISO 17480 Packaging - Accessible Design - Ease of Opening</p> <p>CD/19809 Packaging - Accessible Design – Information and marking</p>	<p>Accessibility requirements for ease of opening were standardized. Published in 2015.</p> <p>Design requirements for visual and tactile markings and letters were being developed. The CD ballot is closed April 2016.</p>
<p>ISO/TMB</p>	<p>IWA16 Community-based integrated life-long health and care services for aged societies</p>	<p>Promotion document for health care for older people.</p> <p>To be published in 2016.</p>
<p>ISO/IEC JTC1/SC35 User interface/ WG6 User interfaces accessibility</p>	<p>ISO/IEC TS 20071-21 Information Technology — User interface component accessibility — Part 21: Guidance on audio descriptions</p>	<p>Recommendations for audiovisual content in an auditory modality in TVs etc. were standardized. Published in 2015.</p>

	<p>ISO/IEC TS 20071-23 Information Technology — User interface component accessibility — Part 23: Guidance on the visual presentation of audio information (including captions and subtitles)</p> <p>ISO/IEC TS 20071-25 Information Technology — User interface component accessibility — Part 25: Guidance on the auditory presentation of subtitles, captions and other visual text</p>	<p>Recommendations on visual presentation in TVs etc. are being developed. Draft is under development.</p> <p>Recommendations on auditory presentation in TVs etc. are being developed. Draft is under development.</p>
<p>IEC/TC59 Performance of household and similar electrical appliances / WG11</p>	<p>IEC/TS62835 TS ed1 Electric toasters for household and similar use — Methods and measurements for improving accessibility</p> <p>IEC 63008 Ed. 1.0 Household and similar electrical appliances — Accessibility of controls, doors, lids and handles</p>	<p>Recommendations on accessibility of toasters were developed. Published in 2015.</p> <p>Recommendations on accessibility of controls, doors, lids, and handles of household appliances are being developed. Draft is under development.</p>
<p>IEC Syc AAL Active assisted living</p>	<p>Work items are under development</p>	<p>Recommendations for active assisted living for older people are being considered.</p>

6.3. Relevant Links

[ISO/TC 173 Assistive products for persons with disability](#)

[ISO/TC 159 Ergonomics](#)

[ISO/TC 122 Packaging](#)

[ISO/IEC JTC 1 Information technology](#)

[IEC/TC 59 Performance of household and similar electrical appliances](#)

[IEC SyC AAL Active Assistive Living](#)

6.4. Date of information and meetings

Committee	Date of last meeting	Date of next meeting	WG/ Standard(s)	Consumer representative(s) involved in the key area
ISO/TC159/WG2	2015/11	2016/05/11	TR22411 2 nd ed	Susan Harker (BSI)
ISO/SC4/WG10	2015/11	2016/05/09	AWI 24507 AWI 21054 AWI 21056 PWI 24506	Susan Harker (BSI)
ISO/TC122/WG9	2015/10	2016/05/09	CD19809	-
IEC/TC59/WG11	2014/10/20	2016/10/14	IEC 63008 Ed. 1.0	-
IEC SyC AAL	2015/11	2016/04/29	-	-

6.5. Key person

For further information, please contact: Ken Sagawa, sagawa-k@aist.go.jp, Japan National Institute of Advanced Industrial Science and Technology.

7. Environmental Issues

7.1. Summary

None of the items is of big relevance to consumers. ANEC (the European Consumer Voice in Standardisation) has expressed concern over life cycle assessment (LCA) based information for labelling in general and, in particular, for consumer information (carbon or environmental footprint) and considers this approach fundamentally flawed. Hence, there is no active involvement in the work of ISO TC 207 and its SC3 (focusing on footprint information and PCRs) at this stage.

7.2. Standards work

Committee	Working draft or standard	Progress or change during reporting year Any action to be taken
ISO/TC 207/SC 3 Environmental labelling	ISO 14024:1999/CD Amd 1 "Environmental labels and declarations — Type I environmental labelling — Principles and procedures — Amendment 1"	DIS approved in December 2015.
ISO/TC 207/SC 3 Environmental labelling	ISO 14026 "Environmental labels and declarations – Principles and Guidance on Communication of footprint information"	Working draft available.
ISO/TC 207/SC 3 Environmental labelling	ISO TS 14027 "Environmental labels and declarations — Type III environmental declarations — Product Category Rule (PCR) development"	Working draft available.

7.3. Relevant links

http://www.iso.org/iso/home/standards_development/list_of_iso_technical_committees/iso_technical_committee.htm?commid=54808

7.4. Date of information and meetings

No information available.

7.5. Key person

For further information, please contact: Franz Fiala, f.fiala@austrian-standards.at, Austrian Standards Institution.

(Page intentionally left blank)

8. Fire Safety

8.1. Summary

ISO TC 92 and its four subcommittees are considering changing technologies in building materials and what goes into a building in all the range of use, from industrial to residential.

A key concern is smouldering and burning materials. Both are risks to life and property. ISO TC 21, 38 and 61 also have concerns related to materials and detection.

The pressing item is the current shortness of time to react and exit when a fire occurs. Along with this are discussions about how to retard fire in materials and products without creating environmental or off gas effects. As consumers we need to be concerned not only about Fire Safety where we live, but where we work, shop, transport, obtain services or treatment – or where vulnerable persons are taken care of.

Additionally, studies show that the time to flashover in a building has declined significantly from what it was 40 years ago. This has impacted the time available for evacuation or exit to safe areas. This needs further attention by various standards committees and the public. In a recent case, the use of mixed furniture led to the death of vulnerable persons and the permanent disabling of some of the caregivers.

8.2. Standards work

Committee/	Working draft or standard	Progress or change during reporting year Any action to be taken
ISO/TC 92/SC 1 Fire initiation and growth	ISO/NP 1182 Reaction to fire tests for products — Non-combustibility test Stage Code:10.99 ICS #: 13.220.50	New.
	ISO/DTS 5660-4 Reaction-to-fire tests — Heat release, smoke production and mass loss rate — Part 4: Measurement of heat release for determination of low levels of combustibility Stage Code: 30.99 ICS #: 13.220.50	This DTS was previously approved to be registered for ballot as a DIS but is now being proposed as a TS.
ISO/TC 92/SC 2 Fire containment	ISO/PRF 3008-3 Fire Resistance Test — Door and Shutter Assemblies — Part 3: Horizontally oriented Stage Code: 50.20 ICS #: 13.220.50, 91.060.50	

	<p>ISO/DTR 12470-1 Fire-resistance tests — Guidance on the application and extension of results — Part 1: Loadbearing elements and vertical and horizontal separating elements Stage Code: 30.60 ICS #: 13.220.40, 13.220.50</p>	This Draft Technical report is now at the end of the vote for a CD.
	<p>ISO/NP TR 15655 Fire resistance — Tests for thermo-physical and mechanical properties of structural materials at elevated temperatures for fire engineering design Stage Code: 10.99 ICS #: 13.220.40</p>	This Technical Report is at starting stage.
	<p>ISO/CD 20902 Fire separating elements exposed to engulfing hydrocarbon fires Stage Code: 30.60 ICS #: 13.220.50</p>	This project is progressing.
<p>ISO/TC 92/SC 3 Fire threat to people and environment</p>	<p>ISO/DIS 12828-2 Validation methods for fire gas analyses — Part 2: Validation of quantification method Stage Code: 40.60 ICS #: 13.220.01</p>	Now at the end of the CD ballot.
	<p>ISO/PRF TR 13571-2 Fire threat to people — Part 2: Methodology and examples of tenability assessment Stage Code: 50.00 ICS #: ICS #: 13.220.01</p>	Proposed as a TR.
	<p>ISO/NP 19677 Guidelines for assessing the adverse impact of wildland fires on the environment Stage Code: 20.20 ICS #: NA</p>	This is just starting.
	<p>ISO/DTS 19700 Controlled equivalence ratio method for the determination of hazardous components of</p>	This is an important Technical Standard under ballot.

	fire effluents — The steady state tube furnace Stage Code: 30.20 ICS #: 13.220.01	
	ISO/DIS 26367-2 Guidelines for assessing the adverse environmental impact of fire effluents — Part 2: Compilation of environmentally significant emissions from fires Stage Code: 40.20 ICS #: 13.220.01	This is proceeding at the DIS stage. If successful it will then proceed to FDIS registration.

8.3. Relevant links

[ISO/TC 92 Fire safety](#)

Studies and reports of interest to consumers:

Proceedings of the furniture flammability and human health summit

<http://library.ul.dev.mblm.com/?document=proceedings-of-the-furniture-flammability-and-human-health-summit>

http://library.ul.com/wp-content/uploads/sites/40/2015/02/UL_WP_Final_UL-Fire-Safety-Research-Recent-and-Current-Studies_v7-HR.pdf

8.4. Information of meetings and consumer participation

Committee	Date of last meeting	Date of next meeting	WG/ Standard(s)	Consumer representative(s) involved in the key area
ISO TC 92/ SC 3 Fire Safety	2015/04	2016/04/14	SC 3	None Identified
ISO TC 92/ SC 1	2015/04	2016/3 rd quarter	SC 1	None identified
ISO TC 92 and SCs	2015/10 and 04 (SCs)	2017/2 nd quarter		None Identified

8.5. Key person

For further information, please contact: G. Rae Dulmage, Rae.dulmage@ul.com, or Emmanuel Sopeju, Emmanuel.sopeju@ul.com, ULC Standards and Underwriters Laboratories Canada.

(Page intentionally left blank)

9. Food Safety

9.1. Summary

ISO committee ISO/TC 34 Food products deals with a wide scope of food and foodstuffs. Its field of activity – and that of its subcommittees – covers practically every agricultural product produced directly or after processing for human and animal consumption.

Structure

ISO/TC 34/SC 2:	Oleaginous seeds and fruits and oilseed meals
ISO/TC 34/SC 3:	Fruits and vegetables and their derived products
ISO/TC 34/SC 4:	Cereals and pulses
ISO/TC 34/SC 5:	Milk and milk products
ISO/TC 34/SC 6:	Meat, poultry, fish, eggs and their products
ISO/TC 34/SC 7:	Spices, culinary herbs and condiments
ISO/TC 34/SC 8:	Tea
ISO/TC 34/SC 9:	Microbiology
ISO/TC 34/SC 10:	Animal feeding stuffs
ISO/TC 34/SC 11:	Animal and vegetable fats and oils
ISO/TC 34/SC 12:	Sensory analysis
ISO/TC 34/SC 15:	Coffee
ISO/TC 34/SC 16:	Horizontal methods for molecular biomarker analysis
ISO/TC 34/SC 17:	Management systems for food safety
ISO/TC 34/SC 18:	Cocoa

ISO/TC scope

Standardization in the field of human and animal foodstuffs, covering the food chain from primary production to consumption, as well as animal and vegetable propagation materials, in particular, but not limited to; terminology, sampling, methods of test and analysis, product specifications, food and feed safety and quality management and requirements for packaging, storage and transportation. Excluded from its scope are products covered by ISO/TC 54, *Essential oils* and ISO/TC 93, *Starch* (including derivatives and by-products).

The main stakeholders concerned with the work of ISO/TC 34

- governments,
- seed (seed technology producers),
- farmers (private, state-owned and co-operatives),
- food manufacturers,
- animal feed producers,
- contract laboratories,
- merchants/retailers,
- exporters/importers,
- consumers.

Social, safety, health, environmental or cultural issues impacting the work of ISO/TC 34

- growing global population,
- increased needs for food and feed products and changing demand to population ageing (tailored and dedicated nutrition, fulfilment of special nutritional demands),
- more results oriented requirements and less means oriented requirements,
- development of private reference documents,
- request for more information on the products (labelling, communication, certification...),
- waste reduction and preservation of the environment,
- sourcing of agricultural products or the food industry,
- increasing speed of launching new food products

(Reference: [ISO TC 34 homepage](#), [BUSINESS PLAN of ISO/TC 34 Food products](#), [TC 34](#))

9.2. Standards work

Committee	Working draft or standard	Progress or change during reporting year Any action to be taken
ISO/TC 34/WG 14	ISO/NP 20635 <i>Infant formula and adult nutritionals – Determination of vitamin C by ultra-performance liquid chromatography with ultraviolet detection</i>	New project approved (2015-05-04)
ISO/TC 34/WG 14	ISO/NP 20636 <i>Infant formula and adult nutritionals – Determination of vitamin D – Ultra high performance liquid chromatography and tandem mass spectrometry (UHPLC-MS/MS)</i>	New project approved (2015-05-04)
ISO/TC 34/WG 16	ISO/DTS 34700 <i>Animal welfare management – General requirements and guidance for organizations in the food supply chain</i>	CD study/ballot initiated (2016-02-09)
ISO/TC 34/WG 17	ISO/CD 18787 <i>Foodstuffs – Determination of water activity</i>	CD approved for registration as DIS (2014-07-11)
ISO/TC 34/WG 18	ISO/DIS 19657 <i>Definition of criteria for a food ingredient to be considered as natural</i>	DIS registered (2016-04-01)
ISO/TC 34/WG 13	ISO/FDIS 12824 <i>Royal jelly – Specifications</i>	FDIS registered for formal approval (2016-02-12)
ISO/TC 34/SC 12 Sensory analysis	ISO/NP 20784 <i>Guidance on substantiation for sensory and consumer claims</i>	New project approved

9.3. Relevant links

[ISO/TC 34 Food products homepage](#)

[ISO/TC 34 Food products standards catalogue](#)

9.4. Date of information and meetings

Committee	Date of last meeting	Date of next meeting	WG/ Standard(s)	Consumer representative(s) in the key area
TC 34/SC 9		2016/05/9-11	Microbiology	
TC 34/SC 4		2016/05/23-24	Cereals and pulses	
TC 34/SC 5		2016/05-06/30-3	Milk and milk products	
TC 34		2016/07/8	Food products	
TC 34/SC 7		2016	Spices, culinary herbs and condiments	
TC 34/SC 12		2016/11/10-11	Sensory analysis	
TC 34/SC 15		2017/04	Coffee	
TC 34/SC 18		2016/04	Cocoa	

9.5. Key person

For further information, please contact: Dr Eunsook Moon, mooneu21@gmail.com, Korean Agency for Technology and Standards

(Page intentionally left blank)

10. Furniture

10.1. Summary

ISO TC 136 is aligning the old ISO standards with the corresponding EN standards.

Safe furniture for children

Child safety standards and toy safety is continuously in development, both at ISO and CEN level, and on their way in votes.

10.2. Standards work

Committee	Working draft or standard	Issue addressed / Progress or change reported
ISO/TC 136 Furniture	The scope of the new WG proposed by SIS ISO 7175-1 Children's cots and folding cots for domestic use – Part 1 safety requirements ISO 7175-2 Children's cots and cots for domestic use – Part 2 Test methods ISO 9221-1 Children's high chairs – Part 1 Safety requirements ISO 9221-2 Children's high chair – Part 2 Test methods	A new working group on children's furniture is under development. It will be decided in April 2016 if China or Sweden will convene this group.
CEN/TC 252 Child use and care articles		Revision of standards for bicycle seats will start
CEN/TC 52 Safety of toys	EN 71-1 EN 71-14 EN 71-8/9/10	Revisions have been published, standards finalised and new revision proposed
CLC 61/WG Toys	EN 62115	Standard is almost finalised

10.3. Relevant links

[ISO/TC 136 Furniture homepage](#)

Child safety:

[CEN/TC 52 Safety of Toys](#)

[CEN/TC 252 Child use and care articles](#)

[ISO/TC 181 Safety of toys](#)

10.4. Date of information and meetings

Committee	Date of last meeting	Date of next meeting	WG/ Standard(s)	Consumer representative(s) involved in the key area
ISO/TC 136 Furniture	Last meeting was in Shanghai in May 2014	As the work is now done in the working groups no plenary meeting has been scheduled.		
CEN/TC 52 Safety of Toys	There has been several meetings of CEN/TC 52 working groups WG 3, WG 5, WG 10 Interpretations groups			
CEN/TC 252 Child use and care articles		April 2016 at NEN		

10.5. Key persons

For further information, please contact: Helen Amundsen, HA@frb.dk, Danish Consumer Council or Imola Ferro, imola.ferro@nen.nl Nederlands Normalisatie-Instituut.

11. Graphical Symbols

11.1. Summary

In this context, “graphical symbols” includes public information symbols, safety signs for use in public areas and on industrial and consumer products, and graphical symbols for use on equipment (“equipment” includes both industrial and consumer products).

ISO/TC 145 is responsible for two areas: developing design and application standards and for the evaluation and registration (where appropriate) of graphical symbols submitted by technical committees, ISO and CEN/CENELEC member bodies and other organizations. Registered graphical symbols are included in ‘catalogue’ standards (see below under individual committee sections).

IEC/TC 3/SC 3C also evaluates and registers graphical symbols for use on equipment. These are mainly from IEC/CENELEC electro-technical committees and many are used on consumer electrical products. (See section on TC 3/SC 3C below).

Key objectives of consumer participation in this work are to ensure as far as possible both that design and application standards take account of consumers’ interests and that graphical symbols intended for consumers are comprehensible and not duplicated. It is also important that technical committees and others submitting symbols for evaluation and registration do so at the earliest possible stage in their development so as to ensure that the appropriate design criteria are followed and the publication of standards is not delayed.

Consumer objectives are being broadly met.

Note: All graphical symbols registered in TC 145 and IEC/TC 3/SC 3C catalogue standards can be viewed and purchased from the ISO Online Browsing Platform. In addition, graphical symbols for use on equipment (both ISO and IEC) are separately available in the IEC/ISO Joint database on graphical symbols for use on equipment (see links at section 3 below).

11.2. Description of new developments under priority area

Committee	WG / Standard(s) affected	Issue addressed / Progress or change reported
ISO/TC 145 Graphical symbols	TC 145’s scope covers safety signs, public information symbols and graphical symbols for use on equipment.	
ISO/TC 145/SC 1 Public information symbols WG 4 Public information symbols (Revision of ISO 7001)	ISO 7001:2007 , <i>Public information symbols</i> This is a catalogue of public information	This standard is under systematic review. Ballot ends 2016-06-15. Four amendments with additional symbols have been published since 2007, and the

<p>WG 5 Public information guidance systems</p>	<p>symbols accepted for registration by SC 1. It also specifies the criteria for the registration of public information symbols.</p> <p>ISO/FDIS 28564-2, <i>Public information guidance systems – Part 1: Design principles and element requirements for location signs and direction signs</i></p> <p>ISO/WD 28564-3, <i>Public information guidance systems – Part 3: Guidelines for the design and use of information index signs</i></p>	<p>standard now comprises 180 public information symbols. Approximately 30 proposals for public information symbols are under consideration.</p> <p>FDIS registered for formal approval – 2016-02-11</p> <p>Working draft under consideration.</p>
<p>ISO/TC 145/SC 2 Graphical symbols – safety identification, signs, shapes, symbols and colours</p> <p>WG 1 Safety identification, shapes, symbols and colours</p>	<p>ISO 7010:2011, <i>Graphical symbols – Safety colours and safety signs – Registered safety signs</i></p> <p>This is a catalogue of safety signs accepted for registration by SC 2. It also specifies criteria for the registration of safety signs.</p> <p>ISO 3864-4:2011, <i>Graphical symbols – Safety colours and safety signs – Part 4: Colorimetric and photometric properties of safety sign materials</i></p> <p>ISO/NP 20560, <i>Safety signs – Pipe and tank marking</i></p>	<p>Six amendments with additional safety signs have been published since 2011, and the standard now comprises 200 safety signs (including a number for use on cruise liners).</p> <p>Over 40 new safety sign proposals are under consideration.</p> <p>Systematic review started. Ballot ends 2016-06-15.</p> <p>Ballot on new work item proposal ends 2016-04-18.</p>

<p>WG 3 Safety-way guidance systems (SWS)</p> <p>WG 4 Water safety signs and beach safety flags</p>	<p>ISO/CD 16069 (Ed 2), <i>Graphical symbols – Safety signs – Safety way guidance systems</i></p> <p>ISO 20712-1:2008, <i>Water safety signs and beach safety flags – Part 1: Specifications for water safety signs used in workplaces and public areas</i></p>	<p>CD issued for vote/comment. Received comments to be discussed at WG3 meeting in mid-April.</p> <p>Systematic review completed. Standard approved.</p> <p>The standard includes 50 registered water safety signs.</p>
<p>ISO/TC 145/SC 3 Graphical symbols for use on equipment</p> <p>WG 1 Coordination and registration of graphical symbols for use on equipment</p>	<p>ISO 7000, <i>Graphical symbols for use on equipment</i></p> <p>This is a catalogue of graphical symbols for use on equipment registered by SC 3.</p>	<p>This standard is frequently updated with the addition of newly approved symbols and the standard now contains some 3,000 symbols.</p>
<p>IEC/TC 3/SC 3C Graphical symbols for use on equipment</p>	<p>IEC 60417, <i>Graphical symbols for use on equipment</i></p> <p>This is a catalogue of graphical symbols for use on equipment developed mainly by IEC product committees and registered by SC 3C</p>	<p>The standard is frequently updated with the addition of newly approved and registered symbols and it now contains some 1,350 graphical symbols.</p>
<p>IEC/TC 3-ISO/TC 10 JWG16 Preparation of instructions for the use of products</p>	<p>IEC/WD 82079-1 Ed 2, <i>Preparation of instructions for use – Structuring, content and presentation – Part 1: General principles and detailed requirements</i></p> <p>This standard is applicable to all types of consumer and industrial products. It includes, inter alia, requirements for the use of safety signs and graphical symbols to convey information to users of products.</p>	<p>Standard under revision. Target for publication of CD is August 2016.</p> <p>This is intended to be the first part of an IEC/ISO series of standards.</p>

11.3. Relevant links and publications

ISO/TC 145 Home page (includes information on submitting graphical symbols for evaluation and registration)

http://www.iso.org/tc_145

ISO Store

<http://www.iso.org/iso/store.htm>

ISO Online Browsing Platform

<https://www.iso.org/obp/ui/#search>

IEC/ISO Joint database for graphical symbols for use on equipment (requires password)

<http://www.graphical-symbols.info/>

[ISO/IEC Guide 74, Graphical symbols – Technical guidelines for the consideration of consumers' needs](#)

[ISO Brochure “ISO committees on horizontal subjects”](#)

[ISO Booklet “The international Language of Graphical Symbols”](#)

[ISO Focus article “Graphical symbols cross borders”](#) (May 2010, p 36)

11.4. Consumer representation in priority area

Committee	Standard(s) affected	Consumer representative(s)
ISO/TC 145 Graphical symbols	See below.	John Perry and Susan Woodhouse (BSI's Consumer and Public Interest Network (CPIN)).
TC 145/SC 1 Public information symbols	ISO 7001 , <i>Public information symbols</i>	Susan Woodhouse, John Perry
TC 145/SC 2 Graphical symbols – Safety identification, signs, shapes, symbols and colours	See WG 1 and WG 4 below.	John Perry, Susan Woodhouse
TC 145/SC 2/WG 1 Safety identification, shapes, symbols and colours	ISO 7010 , <i>Graphical symbols – Safety colours and safety signs – Registered safety signs</i> ISO 3864 series of four parts specifying design principles for safety signs and product safety labels.	John Perry John Perry
SC 2/WG 4 Water safety signs and beach safety flags	ISO 20712 series of three parts covering water safety signs and beach safety flags.	Susan Woodhouse, John Perry

TC 145/SC 3 Graphical symbols for use on equipment	ISO 7000 , <i>Graphical symbols for use on equipment</i>	John Perry
ISO/TC 145/SC 3/WG 1 Coordination and registration of graphical symbols for use on equipment	ISO 7000 Coordination and registration of graphical symbols for use on equipment.	John Perry
IEC/TC 3/SC 3C Graphical symbols for use on equipment	IEC 60417 , <i>Graphical symbols for use on equipment</i>	John Perry
IEC/TC 3-ISO/TC 10 JWG 16	IEC 82079-1 ED 2 , <i>Preparation of instructions for use – Structuring, content and presentation – Part 1: General principles and detailed requirements</i>	John Perry, Gordon Hayward

11.5. Key person

For further information, please contact: John Perry, john@perry18.freeserve.co.uk, British Standards institution.

(Page intentionally left blank)

12. Health Informatics

12.1. Summary

E-Health refers to patient information, electronic and remote means of treatment, diagnosis that can interconnect and interact.

Key elements of concern for consumers are data privacy, accuracy, security timeliness, quality of service, consistency, humanity and a more comprehensive approach on prevention and successful care. E-Health moves health care to a 21st century platform.

There continue to be pockets of success but not the full implementation that was thought. Interoperability within systems and between systems is a dream; privacy is recognized but often hard to standardize; there is still a lot of paper going into the system with even the higher implemented developing countries' systems still dependent on paper being scanned. Care providers have run into costly roadblocks and fees to have interoperability between different e-health systems communicate.

Cybersecurity is a continuing cross-cutting issue. ISO TC 215 continues to work on a considerable amount of standards to resolve some of these issues and in that is working with other Standards Development Organizations (SDOs) and organizations to complete the work. As of March 11, 2016 ISO TC 215 has 153 published standards.

12.2. Standards work

Committee	WG / Standard(s) affected	Issue addressed / Progress or change reported
TC 215 ISO/TC 215/WG 2 Systems and Device Interoperability ISO/TC 215/WG 3 Semantic content ISO/TC 215/WG 4 Security, Safety and Privacy	ISO/AWI TR 13581 Health Informatics – Guidance for maintenance of object identifiers OID Stage Code: 20.00 ICS #: 35.240.80	
TC 215 ISO/TC 215/WG 2 Systems and Device Interoperability ISO/TC 215/WG 3 Semantic content ISO/TC 215/WG 4 Security, Safety and Privacy	ISO/NP 13606-1 Health informatics – Electronic health record communication – Part 1: Reference model Stage Code: 10.99 ICS #: 35.240.80	Though not each of these touch on a consumer directly or an issue they collectively work together to draw a system together. All have a bearing on the final outcome of e-health. Some are just beginning and others are almost completed.
TC 215 ISO/TC 215/WG 2 Systems and Device Interoperability ISO/TC 215/WG 3 Semantic content ISO/TC 215/WG 4 Security, Safety and Privacy	ISO/NP 13606-2 Health informatics – Electronic health record communication – Part 2: Archetype interchange specification Stage Code: 10.99 ICS #: 35.240.80	.

<p>TC 215</p> <p>ISO/TC 215/WG 2 Systems and Device Interoperability ISO/TC 215/WG 3 Semantic content ISO/TC 215/WG 4 Security, Safety and Privacy</p>	<p>ISO/NP 13606-3 Health informatics – Electronic health record communication – Part 3: Reference archetypes and term lists Stage Code: 10.99 ICS #: 35.240.80</p>	<p>Though not each of these touch on a consumer directly or an issue they collectively work together to draw a system together. All have a bearing on the final outcome of e-health. Some are just beginning and others are almost completed.</p>
<p>TC 215</p> <p>ISO/TC 215/WG 2 Systems and Device Interoperability ISO/TC 215/WG 3 Semantic content ISO/TC 215/WG 4 Security, Safety and Privacy</p>	<p>ISO/NP 13606-4 Health informatics – Electronic health record communication – Part 4: Security Stage Code:10.99 ICS #: 35.240.80</p>	
<p>TC 215</p> <p>ISO/TC 215/WG 2 Systems and Device Interoperability ISO/TC 215/WG 3 Semantic content ISO/TC 215/WG 4 Security, Safety and Privacy</p>	<p>ISO/NP 13606-5 Health informatics – Electronic health record communication – Part 5: Interface specification Stage Code: 10.99 ICS #: 35.240.80</p>	
<p>TC 215</p> <p>ISO/TC 215/WG 2 Systems and Device Interoperability ISO/TC 215/WG 3 Semantic content ISO/TC 215/WG 4 Security, Safety and Privacy</p>	<p>ISO/HL7 16527 Health Informatics – HL7 Personal Health Record System Functional Model, Release 1 (PHRS FM) Stage Code: 60.00 ICS #: 35.240.80</p>	
<p>TC 215</p> <p>ISO/TC 215/WG 2 Systems and Device Interoperability ISO/TC 215/WG 3 Semantic content ISO/TC 215/WG 4 Security, Safety and Privacy</p>	<p>ISO/NP TS 16555 Health Informatics: Framework for National Health Information Systems Stage Code: 10.99 ICS #: 35.240.80</p>	
<p>TC 215</p> <p>ISO/TC 215/WG 2 Systems and Device Interoperability ISO/TC 215/WG 3 Semantic content ISO/TC 215/WG 4 Security, Safety and Privacy</p>	<p>ISO/CD 17090-5 Health informatics – Public key infrastructure (PKI) – Part 5: Authentication using Healthcare PKI credentials Stage Code: 30.60 ICS #: 35.240.80</p>	

<p>TC 215</p> <p>ISO/TC 215/WG 2 Systems and Device Interoperability ISO/TC 215/WG 3 Semantic content ISO/TC 215/WG 4 Security, Safety and Privacy</p>	<p>ISO/CD 17117-1 Health informatics – Terminological resources – Part 1: Characteristics Stage Code: 30.60 ICS #: 01.020; 35.240.80</p>	
<p>TC 215</p> <p>ISO/TC 215/WG 2 Systems and Device Interoperability ISO/TC 215/WG 3 Semantic content ISO/TC 215/WG 4 Security, Safety and Privacy</p>	<p>ISO/PRF TS 17251 Health Informatics – Business requirements for a syntax to exchange structured dose information for medicinal products Stage Code: 50.00 ICS #: 35.240.80</p>	
<p>TC 215</p> <p>ISO/TC 215/WG 2 Systems and Device Interoperability ISO/TC 215/WG 3 Semantic content ISO/TC 215/WG 4 Security, Safety and Privacy</p>	<p>ISO/DIS 17523 Health informatics – Requirements for electronic prescriptions Stage Code: 50.23 ICS #: 35.240.80</p>	
<p>TC 215</p> <p>ISO/TC 215/WG 2 Systems and Device Interoperability ISO/TC 215/WG 3 Semantic content ISO/TC 215/WG 4 Security, Safety and Privacy</p>	<p>ISO/DIS 17583 Health informatics – Terminology constraints for coded data elements expressed in ISO Harmonized Data Types used in healthcare information interchange Stage Code: 40.99 ICS #: 35.240.80</p>	<p>Though not each of these touch on a consumer directly or an issue they collectively work together to draw a system together. All have a bearing on the final outcome of e-health. Some are just beginning and others are almost completed.</p>
<p>TC 215</p> <p>ISO/TC 215/WG 2 Systems and Device Interoperability ISO/TC 215/WG 3 Semantic content ISO/TC 215/WG 4 Security, Safety and Privacy</p>	<p>ISO/DTS 18062 Health informatics – Categorical structure for representation of herbal medicaments in terminological systems Stage Code: 30.60 ICS #: 35.240.80</p>	
<p>TC 215</p> <p>ISO/TC 215/WG 2 Systems and Device Interoperability ISO/TC 215/WG 3 Semantic content ISO/TC 215/WG 4 Security, Safety and Privacy</p>	<p>ISO/DTR 18638 Components of Education to Ensure Health Information Privacy Stage Code: 30.99 ICS #: 35.240.80</p>	

<p>TC 215</p> <p>ISO/TC 215/WG 2 Systems and Device Interoperability ISO/TC 215/WG 3 Semantic content ISO/TC 215/WG 4 Security, Safety and Privacy</p>	<p>ISO/DTS 18864 Quality metrics for detailed clinical models Stage Code: 30.60 ICS #: 35.240.80</p>	<p>Though not each of these touch on a consumer directly or an issue they collectively work together to draw a system together. All have a bearing on the final outcome of e-health. Some are just beginning and others are almost completed.</p>
<p>TC 215</p> <p>ISO/TC 215/WG 2 Systems and Device Interoperability ISO/TC 215/WG 3 Semantic content ISO/TC 215/WG 4 Security, Safety and Privacy</p>	<p>ISO/PRF TS 19256 Health informatics – Requirements for medicinal product dictionaries Stage Code: 50.60 ICS #: 35.240.80</p>	
<p>TC 215</p> <p>ISO/TC 215/WG 2 Systems and Device Interoperability ISO/TC 215/WG 3 Semantic content ISO/TC 215/WG 4 Security, Safety and Privacy</p>	<p>ISO/DTS 19844 Health informatics – Identification of medicinal products – Implementation guide for data elements and structures for the unique identification and exchange of regulated information on substances Stage Code: 30.60 ICS #: 35.240.80</p>	
<p>TC 215</p> <p>ISO/TC 215/WG 2 Systems and Device Interoperability ISO/TC 215/WG 3 Semantic content ISO/TC 215/WG 4 Security, Safety and Privacy</p>	<p>ISO/PRF TS 20440 Health informatics – Identification of medicinal products – Implementation guide for ISO 11239 data elements and structures for the unique identification and exchange of regulated information on pharmaceutical dose forms, units of presentation, routes of administration and packaging Stage Code: 50.60 ICS #: 35.240.80</p>	
<p>TC 215</p> <p>ISO/TC 215/WG 2 Systems and Device Interoperability ISO/TC 215/WG 3 Semantic content ISO/TC 215/WG 4 Security, Safety and Privacy</p>	<p>ISO/DTS 20443 Health informatics Identification of Medicinal Products – Implementation Guide for ISO 11615 Data elements and structures for the unique identification and exchange of regulated medicinal product information Stage Code: 30.60 ICS #: 35.240.80</p>	

<p>TC 215</p> <p>ISO/TC 215/WG 2 Systems and Device Interoperability ISO/TC 215/WG 3 Semantic content ISO/TC 215/WG 4 Security, Safety and Privacy</p>	<p>ISO/DTS 20451 Health informatics – Identification of medicinal products – implementation guide for ISO 11616 data elements and structures for the unique identification and exchange of regulated pharmaceutical product information Stage Code: 30.60 ICS #: 35.240.80</p>	
<p>TC 215</p> <p>ISO/TC 215/WG 2 Systems and Device Interoperability ISO/TC 215/WG 3 Semantic content ISO/TC 215/WG 4 Security, Safety and Privacy</p>	<p>ISO/NP TS 21089 Health informatics – Trusted end-to-end information flows Stage Code: 10.99 ICS #: 35.240.80</p>	
<p>TC 215</p> <p>ISO/TC 215/WG 2 Systems and Device Interoperability ISO/TC 215/WG 3 Semantic content ISO/TC 215/WG 4 Security, Safety and Privacy</p>	<p>ISO/DIS 21298.2 Health informatics – Functional and structural roles Stage Code: 40.20 ICS #: 35.240.80</p>	<p>Though not each of these touch on a consumer directly or an issue they collectively work together to draw a system together. All have a bearing on the final outcome of e-health. Some are just beginning and others are almost completed.</p>
<p>TC 215</p> <p>ISO/TC 215/WG 2 Systems and Device Interoperability ISO/TC 215/WG 3 Semantic content ISO/TC 215/WG 4 Security, Safety and Privacy</p>	<p>ISO/DIS 21549-7-2 Health informatics – Patient healthcard data – Part 7: Medication data Stage Code: 40.20 ICS #: 35.240.80</p>	
<p>TC 215</p> <p>ISO/TC 215/WG 2 Systems and Device Interoperability ISO/TC 215/WG 3 Semantic content ISO/TC 215/WG 4 Security, Safety and Privacy</p>	<p>ISO/DIS 25237 Health informatics – Pseudonymisation Stage Code: 40.60 ICS #: 35.240.80</p>	

<p>TC 215</p> <p>ISO/TC 215/WG 2 Systems and Device Interoperability ISO/TC 215/WG 3 Semantic content ISO/TC 215/WG 4 Security, Safety and Privacy</p>	<p>ISO/DIS 27799 Health informatics – Information security management in health using ISO/IEC 27002 Stage Code: 50.00 ICS #: 35.240.80</p>	
<p>TC 215</p> <p>ISO/TC 215/WG 2 Systems and Device Interoperability ISO/TC 215/WG 3 Semantic content ISO/TC 215/WG 4 Security, Safety and Privacy</p>	<p>IEC/CD 62304 Medical device software – Software life cycle processes Stage Code: 30.99 ICS #: 11.040.01, 35.240.80</p>	
<p>TC 215</p> <p>ISO/TC 215/WG 2 Systems and Device Interoperability ISO/TC 215/WG 3 Semantic content ISO/TC 215/WG 4 Security, Safety and Privacy</p>	<p>IEC/DTR 80001-2-8 Application of risk management for IT-networks incorporating medical devices – Part 2-8; Application guidance – Guidance on standards for establishing the security capabilities identified in IEC 80001-2-2 Stage Code: 30.60 ICS #: 11.040.01, 35.240.80</p>	<p>Though not each of these touch on a consumer directly or an issue they collectively work together to draw a system together. All have a bearing on the final outcome of e-health. Some are just beginning and others are almost completed.</p>
<p>TC 215</p> <p>ISO/TC 215/WG 2 Systems and Device Interoperability ISO/TC 215/WG 3 Semantic content ISO/TC 215/WG 4 Security, Safety and Privacy</p>	<p>IEC/CD 82304-1 Health software – Part 1: General requirements for product safety Stage Code: 40.60 ICS #: 35.240.80</p>	

12.3. Relevant links

ISO TC 215

http://www.iso.org/iso/home/standards_development/list_of_iso_technical_committees/iso_technical_committee.htm?commid=54960

Directory of eHealth policies

<http://www.who.int/goe/policies/countries/en/>

Atlas of eHealth country profiles 2015: The use of eHealth in support of universal health coverage

Based on the findings of the 2015 global survey on eHealth

http://www.who.int/goe/publications/atlas_2015/en/

12.4. Date of information and meetings

Committee	Date of last meeting	Date of next meeting	WG/ Standard(s)	Consumer representative(s) in the key area
TC 215/Health Informatics	2015/11	2016/05/2-3	NA	Limited, often through professionals who work with consumers or groups which have a consumer member section

12.5. Key person

For further information, please contact: Rae Dulmage, Rae.dulmage@ul.com, ULC Standards and Underwriters Laboratories of Canada.

(Page intentionally left blank)

13. Household Appliances (performance)

13.1. Summary

IEC TC 59, Performance of household electrical appliances, its Subcommittees and Working Groups are responsible for developing standards for measuring the performance of electrical household appliances. These standards normally describe only test methods, without setting any requirements.

From consumers' point of view it is important that the test methods are based on consumer behaviour and provide reproducible results, so that the consumer can rely on declared values (e.g. related to energy or water consumption) and can compare the performance of appliances.

13.2. Standards work

Committee	Working draft or standard	Progress or change during reporting year Any action to be taken
IEC/TC 59 Performance of Household Electrical Appliances		
WG 15 Connection of household appliances to smart grids and appliances interaction		
WG 16 Performance evaluation method of intelligent mobile robot platform for household and similar applications		
SC 59 A Dishwashers	IEC 60436 Ed. 4.0 Electric dishwashers for household use – Methods for measuring the performance	The 4th edition was published in October 2015. The main improvements are: - Combining the cleaning and drying performance evaluations into one test, along with the energy and water consumption evaluation. - new dish load items were incorporated which reflect consumer use. New items are: stainless pots, coffee mugs, melamine plastic items, and glass bowls.
SC 59 D Home laundry appliances	IEC 60456 Ed. 5.0	Work on the 6th edition is still going on.
SC 59 F Floor treatment appliances	IEC 60312-1 Vacuum cleaners for household use – Part 1: Dry vacuum cleaners	Standards for cordless vacuum cleaners and high pressure and steam cleaners as well as wet

	<p>– Methods for measuring the performance IEC 62885-3 Surface cleaning appliances – Part 3: Wet carpet cleaning appliances – Methods for measuring the performance IEC 62929 Cleaning robots for household use – Dry cleaning – Methods of measuring performance</p>	hard floor cleaning appliances are under development.
<p>SC 59 L Small appliances</p>	<p>IEC 60661 Methods for measuring the performance of electric household coffee makers IEC 60442 Toasters IEC 60496 Warming plates IEC 60530 Kettles and jugs IEC 60619 Food preparation appliances IEC 61309 Deep-fat fryers IEC 61817 Portable coking appliances IEC 60311 Irons</p>	Standards for electric hair clippers or trimmers, spray toilet seats and food slicers are under development.
<p>SC 59 K Ovens and microwave ovens, cooking ranges and similar appliances</p>	<p>IEC 60350-1 Household electric cooking appliances – Part 1: Ranges, ovens, steam ovens and grills – Methods for measuring performance IEC 60350-2 Part 2: Hobs IEC 60705 Household microwave ovens – Methods for measuring performance</p>	
<p>SC 59 M Cooling and freezing appliances</p>	<p>IEC 62552-1 Household refrigerating appliances – Characteristics and test methods - Part 1: General requirements IEC 62552-2 Part 2: Performance requirements IEC 62552-3 Part 3: Energy consumption and volume</p>	

13.3. Relevant links

IEC website; TC Dashboard

http://www.iec.ch/dyn/www/f?p=103:7:0:::FSP_ORG_ID,FSP_LANG_ID:1275,25

13.4. Date of information and meetings

Committee	Date of last meeting	Date of next meeting	WG/ Standard(s)	Consumer representative(s) involved in the key area
IEC/TC 59 Performance of Household Electrical Appliances	Tokyo, October 2014	Frankfurt, 14. October 2016	IEC 60704-1 <i>Noise-General</i> IEC 60704-3 <i>Noise-Determining and verifying declared values</i> IEC 60704-2-(1,2,3,4,5,6,7,8,9,11,14) <i>Particular requirements</i> IEC 61592 TR <i>Panel testing</i> IEC 61923 TR <i>Repeatability and reproducibility</i> IEC 61591 <i>Range hoods</i> IEC 61254 <i>Electric shavers</i> IEC 61855 <i>Household electrical hair care appliances - Methods of measuring the performance</i> IEC 62301 <i>Household electrical appliances - Measurement of standby power</i> IEC 60675 <i>Direct-acting room heaters</i>	K Both, DIN Consumer Council, DKE G. Heilmann, ANEC
TC 59 CAG , Chairman's Advisory Group (CAG)				K Both, DIN Consumer Council, DKE
SC 59 A Dishwashers	Tokyo, October 2014	Frankfurt, 8.October 2016	IEC 60436	G Heilmann, DIN Consumer Council, DKE
SC 59 A/WG 1 Standard detergent and standard rinse agent				G Heilmann, DIN Consumer Council, DKE J Kjeldgaard, Danish Consumer Information Centre, DS
SC 59 A/WG 2 Dishwasher tests				

SC 59 C Heating Appliances	Tokyo, October 2014	Frankfurt, 11.October 2016	IEC 60299 <i>Blankets</i> IEC 61255 <i>Heating pads</i> IEC 60379 <i>Storage water heaters</i> IEC 60531 <i>Thermal storage room heaters</i>	
SC 59 D Home laundry appliances	Tokyo, October 2014	Frankfurt, 13.October 2016	IEC 60456 <i>Washing machines</i> IEC 61121 <i>Tumble dryers</i> IEC 62512 <i>Washer-Dryer</i>	
SC 59 D/WG 13 Test Materials				J Kjeldgaard, Danish Consumer Information Centre, DS
SC 59D/AG 17 Global application of 60456				J Kjeldgaard, Danish Consumer Information Centre, DS
SC 59D/WG 18 Uncertainty				J Kjeldgaard, Danish Consumer Information Centre, DS
SC 59 D/WG 19 Reference machine and programs				
SC 59 D/WG 20 Rinsing-efficiency				
SC 59 D/MT 14 Maintenance team for IEC 61121 & IEC 62512				J Kjeldgaard, Danish Consumer Information Centre, DS
SC 59 D/ MT 15 Maintenance team for IEC 60456				J Kjeldgaard, Danish Consumer Information Centre, DS
SC 59 F Surface cleaning appliances	Tokyo, October 2014	Frankfurt, 13.October 2016		

SC 59 F/WG 3 Dry surface cleaning appliances			IEC 60312-1 <i>Dry vacuum cleaners</i>	
SC 59 F/WG 4 Wet surface cleaning appliances			IEC 62885-3 <i>Wet carpet cleaning appliances</i>	
SC 59 F/WG 5 Surface cleaning robots			IEC 62929 <i>Cleaning robots for household use - Dry cleaning</i>	
SC 59 F/WG 6 Commercial surface cleaning machines			IEC/PAS 62611 <i>Vacuum cleaners for commercial use</i>	
SC 59 F/WG 7 Methods of measuring performance of vacuum cleaner under battery operation				
SC 59 K Ovens and microwave ovens, cooking ranges and similar appliances	Tokyo, October 2014	Frankfurt, 11.October 2016	IEC 60705 <i>Microwave ovens</i> IEC 60350-1 <i>Ranges, ovens, steam ovens and grills</i> IEC 60350-2 <i>Hobs</i> IEC 61591 <i>Household range hoods</i>	
SC 59 L Small appliances	Tokyo, October 2014	Frankfurt, 12.October 2016	IEC 60442 <i>Toasters</i> IEC 60530 <i>Kettles and jugs</i> IEC 60619 <i>Food preparation appl. Amendment 1</i> IEC 60661 <i>Coffee makers</i> IEC 60496 <i>Warming plates Amendment 1 & 2</i> IEC 61309 <i>Deep-fat fryers</i> IEC 61817 <i>Portable appliances for cooking, grilling and similar use</i> IEC 60508 <i>Ironing machines</i>	K Both, DIN Consumer Council, DKE

SC 59 L/MT 1 Maintenance of IEC 60311			IEC 60311 <i>Electric irons Amendment 1 & 2</i>	K Both, DIN Consumer Council, DKE
SC 59 M Cooling and freezing appliances	Minsk, 15. October 2015	Frankfurt, 13.October 2016	IEC 62552 Parts 1,2,and 3 <i>Household refrigeration appliances – Characteristics and test methods</i>	

13.5. Key person

For further information please contact: Karin Both, Karin.both@din.de, DIN Consumer Council, Germany.

14. Household Appliances (safety)

14.1. Summary

- To prepare safety requirements for electrical appliances primarily for household purposes, but also for other equipment and appliances in similar fields.
- Key consumer objective is to protect from safety hazards such as fire, electric shocks, burns and mechanical hazards.
- Focus on safe surface temperatures of electrical appliances for all users (consumers) and especially children.
- Mechanical hazards such as falling ceiling fans are also addressed by this technical committee in addition to electrical and fire hazards.
- The aim of consumer participation is to put consumer's perspective on developing a new standard and revising the existing standards.

14.2. Standards work

Committee	Working draft or standard	Progress or change during reporting year Any action to be taken
IEC TC 61 Safety of household and similar electrical appliances	http://www.iec.ch/dyn/www/f?p=103:30:0:::FSP_ORG_ID,FSP_LANG_ID:1236,25	Same as left box
IEC TC 61 SC 61B Safety of microwave appliances for household and commercial use	http://www.iec.ch/dyn/www/f?p=103:30:0:::FSP_ORG_ID,FSP_LANG_ID:1346,25	Same as left box
IEC TC 61 SC 61C Safety of refrigeration appliances for household and commercial use	http://www.iec.ch/dyn/www/f?p=103:30:0:::FSP_ORG_ID,FSP_LANG_ID:1349,25	Same as left box
IEC TC 61 SC 61D Appliances for air-conditioning for household and similar purposes	http://www.iec.ch/dyn/www/f?p=103:30:0:::FSP_ORG_ID,FSP_LANG_ID:1351,25	Same as left box
IEC TC 61 SC61H Safety of electrically-operated farm appliances	http://www.iec.ch/dyn/www/f?p=103:7:0:::FSP_ORG_ID,FSP_LANG_ID:1356,25	Same as left box
IEC TC 61 SC61J Electrical motor-operated cleaning appliances for commercial use	http://www.iec.ch/dyn/www/f?p=103:30:0:::FSP_ORG_ID,FSP_LANG_ID:1357,25	Same as left box

WG 30 Cosmetic and beauty appliances incorporating lasers and intense light sources	http://www.iec.ch/dyn/www/f?p=103:30:0::::FSP_ORG_ID,FSP_LANG_ID:1236,25	Same as left box
WG 31 IEC 60335-1 Batteries	Same as above	Same as left box
WG 33 IEC 60335-2-30 Portable fan heaters	“	Same as left box
WG 35 IEC 60335-2-35 Instantaneous water heaters	“	Same as left box
WG 38 60335-2-7 Washing machines	“	Same as left box

14.3. Relevant links

IEC TC 61 Safety of household and similar electrical appliances

http://www.iec.ch/dyn/www/f?p=103:7:0::::FSP_ORG_ID,FSP_LANG_ID:1236,25

IEC TC 23 Electrical accessories

http://www.iec.ch/dyn/www/f?p=103:7:0::::FSP_ORG_ID:1299

To prepare standards for electrical accessories for household and similar purposes, the word 'similar' including locations such as offices, commercial and industrial premises, hospitals, public building, etc. These accessories:

- are intended for fixed installation, or for use in or with appliances and other electrical or electronic equipment, and may include electronic components.
- are normally installed by instructed or skilled persons and are normally used by ordinary persons.

IEC/TC 34 Lamps and related equipment

http://www.iec.ch/dyn/www/f?p=103:7:0::::FSP_ORG_ID:1235

To prepare international standards regarding specifications for:

- lamps (including LEDs) and glow starters
- lamp caps and holders
- lamp control gear
- luminaires
- miscellaneous related equipment not covered by a project of another technical committee.

IEC/TC 35 Primary cells and batteries

http://www.iec.ch/dyn/www/f?p=103:7:0::::FSP_ORG_ID:1237

To prepare international standards for primary cells and batteries, particularly those relating to specifications, dimensions, performance and guidance on safety matters.

ISO/TC 86 Refrigeration and air-conditioning

http://www.iso.org/iso/iso_technical_committee%3Fcommid%3D50356

Standardization in the fields of refrigeration and air-conditioning, including terminology, mechanical safety, methods of testing and rating equipment, measurement of sound levels, refrigerant and refrigeration lubricant chemistry, with consideration given to environmental protection. The scope includes factory-assembled air-conditioners (cooling), heat pumps, dehumidifiers, refrigerants, and refrigerant reclaiming and recycling equipment as well as other devices, components and equipment such as humidifiers, ventilation equipment and automatic controls used in air-conditioning and refrigeration systems that are not covered by other ISO technical committees.

14.4. Information of meetings and consumer participation

Committee	Date of last meeting	Date of next meeting	WG/ Standard(s)	Consumer representative(s) involved in the key area
IEC TC 61 Safety of household and similar electrical appliances	2015-11-13 to 2015-11-24 Australia (Sydney)	2016-05-16 to 2016-05-20 Mexico (Mexico City)	http://www.iec.ch/dyn/www/f?p=103:30:0:::FSP_ORG_ID,FSP_LANG_ID:1236.25	N/A

14.5. Key person

For further information, please contact: John Drengenberg, john.p.drengenberg@us.ul.com, Underwriters Laboratories Inc. United States, or Jun Young Choi, liya67@ktl.re.kr, Korean Testing Laboratory.

(Page intentionally left blank)

15. Image Safety

15.1. Summary

With the development of imaging technology in the IT field, flashing and moving images as well as 3D images appear frequently in the screens of TVs or game machines in our daily life which may cause undesirable biological effects on viewers such as; photosensitive seizures, motion sickness, visual fatigue etc.

A standard content design to avoid such undesirable effects is required to protect consumers from these image hazards. The effects are sensitive for children in particular and a warning system for parents might be useful to protect children from these hazards.

15.2. Standards work

Committee	Working draft or standard	Progress or change during reporting year Any action to be taken
ISO/TC159/SC4 Ergonomics of human system interaction / WG12	ISO 9241-391 Part 391: Requirements, analysis and compliance test methods for the reduction of photosensitive seizures	A standard for the reduction of photosensitive seizures. Published in 2016
	ISO 9241-392 Part 392: Ergonomic recommendations for the reduction of visual fatigue from stereoscopic images	Recommendations for the reduction of visual fatigue caused by 3D images. Published in 2015.
	A new work item for the reduction of motion sickness is being planned.	

15.4. Date of information and last meeting

Committee	Date of last meeting	Date of next meeting	WG/ Standard(s)	Consumer representative(s) involved in the key area
TC159/SC4	2015/10	2016/11/7	-	JACONET (name changed from NCOS, Japan)

15.5. Relevant links

[TC159/SC4 Ergonomics of human-system interaction](#)

15.6. Key person

For further information, please contact: Ken Sagawa, sagawa-k@aist.go.jp, National Institute of Advanced Industrial Science and Technology, Japan.

(Page intentionally left blank)

16. Mechanical contraceptives

16.1. Summary

No summary provided.

16.2. Standards work

Committee	Working draft or standard	Progress or change during reporting year Any action to be taken
ISO TC 157	No specific draft or standard	<u>32nd MEETING OF ISO TC 157 Sept 2016</u> ISO TC 157 resolved to seek liaison with ISO TC 194 Biological and clinical evaluation of medical devices with respect to personal lubricants.
ISO TC 157	ISO/NP 16038 Male condoms – Guidance on the use of ISO 4074 and ISO 23409 in the quality management of natural rubber latex condoms and synthetic condoms	<u>32nd MEETING OF ISO TC 157 Sept 2016</u> ISO TC 157 resolved to amend ISO NP 16038 as agreed at the meeting and submit the revised document as DIS for ballot. Comments on the DIS will be discussed in the next meeting of WG14 in September 2016.
ISO TC 157	ISO/NP 19351 Fallopian Ring – Requirements and test methods	<u>32nd MEETING OF ISO TC 157 Sept 2016</u> ISO TC 157 noted that compilation of the comments on the working draft had been circulated. The amended draft standard will be circulated to the working group members.
ISO TC 157	ISO/DIS 19671 Additional Lubricants for Condoms – Effect on Condom Strength	<u>32nd MEETING OF ISO TC 157 Sept 2016</u> ISO TC 157 noted that ISO DIS 19671 will be issued for balloting by member bodies from 2015-10-07 till 2016-01-07. Therefore the comments received will be discussed at next meeting.
ISO TC 157	ISO DIS 11249 Mechanical contraceptives – Guidance for clinical evaluation of intra-uterine contraceptive devices (IUDs)	<u>32nd MEETING OF ISO TC 157 Sept 2016</u> ISO TC 157 resolved that ISO DIS 11249 will be revised and edited in accordance with

		comments from the SOV and discussion at the working group meeting and the revised document will be submitted for ballot as a 2nd DIS.
ISO TC 157	ISO DIS 25841 Female condoms – Requirements and test methods	<u>32nd MEETING OF ISO TC 157 Sept 2016</u> ISO TC 157 resolved that ISO DIS 25841 has been circulated for voting and is scheduled to be closed on 3rd November 2015. The comments received will be discussed by correspondence. Given the nature of some of the expected technical changes, it was agreed that the revised document will be submitted for ballot as a 2nd DIS.
ISO TC 157	ISO/DIS 29943-1 Condoms - Guidance on clinical studies – Part 1: Male condoms, clinical function studies based on self-reports	<u>32nd MEETING OF ISO TC 157 Sept 2016</u> ISO TC 157 noted that ISO DIS 29943-1 has received 100 % approval and all comments received are considered to be editorial. The ISO/DIS 29943-1 will be submitted to ISO/CS for publication two weeks after the meeting.
ISO TC 157	ISO/DIS 29943-2 Condoms – Guidance on clinical studies – Part 2: Female condoms, clinical function studies based on self-reports	<u>32nd MEETING OF ISO TC 157 Sept 2016</u> ISO TC 157 noted that ISO DIS 29943-2 has received 100 % approval and all comments received are considered to be editorial. The ISO DIS 29943-2 will be submitted to ISO/CS for publication two weeks after the meeting.
ISO/TC 157	ISO 23409:2011 Male condoms – Requirements and test methods for condoms made from synthetic materials	<u>32nd MEETING OF ISO TC 157 Sept 2016</u> ISO TC 157 resolved that ISO 23409:2011 which is due for systematic review on 15 January 2016 will be confirmed.
ISO/TC 157		<u>32nd MEETING OF ISO TC 157 Sept 2016</u>

16.3. Relevant links

[ISO TC 157 Non-systemic contraceptives and STI barrier prophylactics](#)

16.4. Information of meetings and consumer participation

Committee	Date of last meeting	Date of next meeting	WG/ Standard(s)	Consumer representative(s) (involved in the key area)
ISO/TC 157	2015/09	2016/09	See above	BABIN, INC

16.5. Key person

For further information, please contact: Charles Babin, c.babin@inc60.fr, Institut National de la Consommation, France.

(Page intentionally left blank)

17. Nanotechnology

17.1. Summary

a) Background

Nanotechnology is one of the 'emerging technologies'; other examples being biotechnology, synthetic biology and fine bubbles technology (which may also come under the umbrella of nanotechnology depending on their scale). Non-biological manufactured nanomaterials are increasingly used in industry and society; so their utility, risks and benefits throughout their life-cycle are important topics for inclusion both in detailed standards work and in the larger discussions of consumer and societal issues.

b) Main Consumer Issues

Nanomaterials are typically used to achieve new or improved functionality of a process or product. 'Nano-enabled' or 'nano-enhanced' devices or systems use some aspect of nanotechnology to create or enhance functionality. 'Nano-enabled' refers to functionality that is not possible without nanotechnology; whereas 'nano-enhanced' improves an existing function.

Key areas for consumer attention are:

- Cooperation among national and international standards institutions in developing safety, regulatory and marketing frameworks for the sale, use and disposal of products in an appropriate ethical manner.
- Environmental safety/sustainability – life cycle chain of both industrial production and products – covering both end of life and end of consumer use.
- Human health exposure: effects over short/long-term for consumers and occupational healthcare workers.
- Traceability/biomarkers and other indicators.
- Labelling/other information: utility, safety and informed choice.
- Interface of nanotechnology with biotechnology and industrial and medical innovation to promote improved health outcomes and reduce health inequalities.

There are widespread and diverse applications: health (RNA-based therapeutics, predictive analytics, human microbiome therapeutics, vaccines); energy (nanosolar paints, grid-scale electricity storage, nanowire lithium ion batteries); food (nano-structured carbon composites for packaging, cellulosic materials); textiles/surfaces (anti-microbials, anti-fog treatments); water (efficient filtering, metal-mining from desalination brine [the new gold-rush!]) and entertainment/business (wearable electronics, screenless displays, brain computer interfaces), the list is endless.

c) Key Consumer Objectives:

- To ensure consumer concerns are embedded in the approach to all work items where appropriate;
- To identify future or potential new or novel aspects of nano-development that may impact society;
- To maintain direct communications with other consumer representatives working in this area.

17.2. Standards work

Committee	Working draft or standard	Progress or change during reporting year Any action to be taken
ISO TC 229 JWG1	Multiple – on Terminology	Work completed on core terms; descriptions for nanocoatings/layers. Ongoing for: plain language explanations; quantum phenomena; graphene & 2D materials; nanostructured materials. New work on Nanocellulosic materials. Initiative to encourage new TC 229 and TC 113 (Electrical and Electronic Products) to develop more industrially-focused standards.
ISO TC 229 WG2	Multiple – on Assays Environmental, occupational health, medicine	Multiple streams of work. Labelling key ongoing item. Voluntary labelling document published in 2014 needs updating. A pre-work item on traceability expected at 2016 Plenary in November. A major initiative with 4 aims of traceability: Empowerment for consumers in decision-making; Increased trust between producers and users; Providing more information within the supply chain; Facilitating product security and 'watermarking'.
ISO TC 229 CASD WG	Consumer & Societal Dimensions	Update on work of TC 229. Agreed to update the 2009 Working Plan. Look to establish formal liaison with TC 279 (Biotechnologies) and the new OECD Working Party on Biotechnology, Nanotechnology and Convergent Technology (BNCT)
ISO TC 220 Sustainability WG	Group developed N1075 <i>Guidance & Questions on Sustainable Development</i> which is an annex to ISO Guide 82	RESOLUTION 20/2015 passed, referring to ISO/TMB Resolution 10/2010, Guide on incorporating sustainability aspects into standardization, and noting ISO Guide 82:2014, that Working Group convenors, project leaders

		and experts promote the consideration of sustainability in their work using N1075 <i>Guidance and questions on sustainable development</i> , including in the development and <i>balloting</i> of new work item proposals, ongoing work, and revisions of existing documents.
ISO TC 229 Nano Bio Study Group		Not accorded Working Group status. NWIPs being allocated to existing working groups. Nano-bio area of high interest. RESOLUTION 19/2015 (Edmonton) agreed on the need to recruit more experts on 'nanotechnology applications in biological systems', to assist with work items that are anticipated to be undertaken, and encouraged National Standards Body mirror groups to identify such experts.

17.3. Relevant links

[ISO TC 229 Nanotechnologies home page](#)

17.4. Information of meetings and consumer participation

Committee	Date of last meeting	Date of next meeting	WG/ Standard(s)	Consumer representative(s) involved in the key area
ISO TC 229	2015/10	2016/03/31	Consumer & Societal Dimension WG – Webconference	Sue McGinty
ISO TC 229	2015/10	2016/05/10	JWG1	Sue McGinty

17.5. Key person

For further information, please contact: Dr Sue McGinty, mcgintysue@hotmail.com, British Standards Institution

(Page intentionally left blank)

18. Online reputation

18.1. Summary

ISO/TC 290 Online Reputation was created in 2014 and is led by AFNOR. The Chair is Laurent Petit (the TC counts 11 P-members and 15 O-members).

The impact on business, consumers and individuals of online reputation is highly linked to trust in social media. Online reputation encompasses consumer online reviews; increasingly used by consumers, worldwide, and for ever more issues. The problem of the credibility of consumers' reviews is crucial.

The first topic in development is a proposal for Online Consumer Reviews. The work is conducted by WG 1, in which 6 countries participate (Canada, China, Finland, France, Germany, UK). The convenor is Howard J. Deane (Consumer Council of Canada).

Consumers International and ANEC are both liaisons to the committee.

18.2. Standards work

Committee	WG / Standard(s) affected	Issue addressed / Progress or change reported
ISO/TC 290 Online Reputation	WG 1 Online Consumer Reviews ISO/NP 20488 <i>Online Consumer Reviews – Principles and requirements for collection, moderation and delivery processes for online consumer reviews</i>	The NWI was approved in February 2015. The next step is the CD (committee draft). To be noted : - discussion about the anonymization of reviews; the importance of the protection of personal data is crucial in some countries, whereas reviews can not be totally anonymous in others. - discussion about the possibility or not to access historical opinions after a change of service provider. The DIS is expected for the 4 th quarter of 2016. The FDIS is expected before February 2017 and the publication of the international standard (ISO 20488) is expected before February 2018. The standard is not directly intended for certification. National organizations will be able to create their own certification process around the

		standard; organizations will have the possibility to claim conformity to the standard. ISO 20488 will be compatible with ISO 9001 (but conformity to ISO 9001 will not be needed; it is not a prerequisite).
	WG 2 Vocabulary	A resolution established the WG. A convenor has not yet been found.

18.3. Relevant links

Homepage of [ISO/TC 290 Online Reputation](#)

Article in [ISO Focus November-December 2014](#)

Get involved in this work? Questions/comments

- Contact your National Standardization Body or contact Copolco@iso.org

18.4. Date of information and meetings

Next meeting: ISO/TC 290 - 2016 September 12/15 – Berlin

Committee	WG / Standard(s) affected	Consumer representative(s)
ISO TC 290 Online reputation	WG 1 ISO/NP 20488	Ratna Devi Nadarajan (DSM, Malaysia) Julie Hunter (Liaison ANEC/CI) Ehud Peleg (SII, Israel) Michela Vuerich (Liaison ANEC/CI)

18.5. Key person

For further information, please contact: Rémi Reuss, remi.reuss@afnor.org, AFNOR, France.

19. Packaging

19.1. Summary

The most significant new development is launch of work in early 2016 on the revision of ISO/IEC Guide 41, *Packaging – Recommendations for addressing consumer needs*. The newly established COPOLCO Working Group 16, led jointly by Sandra Herrera (ICONTEC – Colombia), and Christine Heemsker (BSI – United Kingdom), held its first outreach meeting in May 2015 during the week of the COPOLCO Plenary. Since then, it has developed a preliminary working draft of the Guide and a set of proposals for the working group to consider at a full working group meeting, to be held on July 28-29 2016 in Reston, Virginia at the invitation of ANSI.

The technology and business landscape of packaging have changed a great deal since Guide 41's last revision in 2003. The packaging industry has evolved, and consumers care more about new topics such as migration (leaching) from packaging or packaged products. While primarily destined for use by experts on packaging, ISO/IEC Guide 41 should also be accessible to non-experts. The convenors have therefore proposed to add more terms and definitions to aid understanding, additional references e.g. to ISO/IEC Guide 37 on instructions for use of consumer products, and more explicit references to expiration dates such as perishable products to be placed on the packaging.

The proposals also include recommendations to update the content to take account of persons with disabilities and to update obsolete content on reusable packaging and additional safety warnings.

19.2. Standards work

Committee	Working draft or standard	Progress or change during reporting year Any action to be taken
ISO/TC122/ SC 5/WG 27 Child resistant packaging	<p>EN ISO 8317 <i>Packaging — Child-resistant packaging — Requirements and testing procedures for reclosable packages</i></p> <p>EN ISO 13127 : 2012 <i>Packaging — Child resistant packaging — Mechanical test methods for reclosable child resistant packaging systems</i></p>	<p>No news</p> <p>Major concerns regarding the development of EN ISO 13127 "Packaging — Child resistant packaging — Mechanical test methods for reclosable child resistant packaging systems". Consequently, consumers was not in the position to support the revision of EN ISO 8317 with a view to referencing EN ISO 13127, No approval of ISO/DIS 8317 and prEN ISO 8317 from a consumer point of view.</p>

	<p>EN 14375: 2003 <i>Packaging — Child resistant non-reclosable packaging for pharmaceutical products — Requirements and testing</i></p>	<p>EN ISO 13127 gives a wide room for interpretation, leaves the door open to misuse and cannot be enforced. This could result in packages being put on the market which are not child resistant. The reference to EN ISO 13127 is therefore inadequate</p> <p>The revised standard has been out for formal vote. The result is not known yet.</p>
--	--	---

19.3. Relevant links

ISO/TC 122 homepage:

http://www.iso.org/iso/home/standards_development/list_of_iso_technical_committees/iso_technical_committee.htm?commid=52040

19.4. Information of meetings and consumer participation

Committee	Date of last meeting	Date of next meeting	WG/ Standard(s)	Consumer representative(s) in the key area
<p>ISO/TC 122 Packaging</p>	<p>Last meeting was in February 2016 in Paris</p>	<p>?</p>	<p>SC 3/WG 3 Child resistant packaging EN ISO 8317 <i>Child resistant packaging — Requirements and testing procedures for reclosable packages</i> EN ISO 13127 : 2012 <i>Packaging — Child resistant packaging — Mechanical test methods for reclosable child resistant packaging systems</i></p>	<p>A: Dr. Franz Fiala Österreichisches Normungsinstitut Postfach 130 A -1021 Wien 2 Page 13 Franz Fiala Tel +43 1 21300 709 Fax +43 1 21300 328</p>

19.5. Key person

For further information, please contact: Helen Amundsen, HA@fbr.dk, Danish Consumer Council.

20. Product Safety (horizontal Issues)

20.1. Summary

The Product Safety Working Group (PS WG) operates as a standing committee under the authority of ISO/COPOLCO. The group investigates how adequately the issue of safety is being addressed within ISO's system of standardization.

The PS WG supports the ISO/COPOLCO Chair and Secretary by providing information on the safety of products for consumers and highlighting current and future areas of concern, particularly for developing countries and emerging economies. Our mandate is:

- to promote the design, manufacture, assembly, sale and disposal of safer consumer products via COPOLCO and ISO
- to develop greater consistency and coherence in requirements for safety in Standards
- to encourage networking and communication between COPOLCO and ISO members and to coordinate with IEC on safety issues for common areas of interest on issues of safety and emerging issues
- to respond to calls for information and advice on product safety issues.

20.1.1 Standards work

Committee	WG / Standard(s) affected	Issue addressed / Progress or change reported
COPOLCO Working Group 4 Product Safety	Revision of ISO/IEC Guide 50, <i>Safety aspects – Guidelines for child safety</i>	Published December 2014
	Revision of ISO/IEC Guide 51, <i>Safety aspects – Guidelines for their inclusion in standards</i>	Published April 2014
	Revision of ISO/IEC Guide 71, <i>Guide for addressing accessibility in standards</i>	Published December 2014
	Submission of NWIP ISO/IEC 82079, <i>Preparation of instructions – Part 2 Provisions for instructions for use of self-assembly products</i>	Submitted July 2014, ISO TC 10 and IEC TC 3 rejected the NWIP due to lack of nominated experts. Topic will be dealt with in ISO/IEC JWG 16 (responsible for revising IEC 82079-1)
	Submission of NWIP <i>Components of consumer products or packaging likely to be removed or held by mouth-safety requirements and mechanical test methods</i>	Submitted July 2014 to ISO/TC 10 NWIP was not accepted. Topic was forwarded to COPOLCO WG 16 Guide 41 revision

	The series of IEC 60335 <i>Electrical household and similar appliance standards</i>	The PS WG continues to support ANEC in exclusion clause modification and lowering external surface temperature of household appliances.
	IEC TC 61, <i>Safety of household and similar electrical appliances</i> IEC 62115 Ed. 2.0, <i>Electric toys – Safety</i>	The PS WG supported inclusion of annex J, related to safety of remote controls for electrical ride-on toys, to prevent identified safety hazards in the 2nd edition of IEC-62115 / EN-62115IEC. IEC-62115.

20.1.3. Relevant links

[Product Safety Working Group Report to the COPOLCO Plenary in June 2016](#)

[ISO Consumer Update 25 – March 2016](#)

[Keeping kids safe with a new international guide from ISO and IEC \(2015-01-28\) - ISO](#)

[ISO, IEC and ITU take accessibility to new heights \(2014-12-04\) - ISO](#)

20.1.4. Date of information and meetings

Committee	Date of last meeting	Date of next meeting	WG/ Standard(s)	Consumer representative(s) in the key area
COPOLCO Working Group 4 Product Safety	4 Nov 2015 with Chairs Group	16 June 2016 at COPOLCO Plenary	Product Safety Standards	Karin Both, Consumer Council, German Institute for Standardization (DIN) Dr Eunsook Moon, Korean Agency for Technology and Standards (KATS), Korea Testing & Research Institute (KTR)

20.1.5. Key person

For further information, please contact: Dr Eunsook Moon mooneu21@gmail.com, Korean Agency for Technology and Standards (KATS), Korea Testing & Research Institute (KTR)

20.2 Additive manufacturing (3D Printing)

20.2.1. Summary

Additive Manufacturing is used to make prototypes, tools and production parts. In comparison to conventional methods where parts are moulded into specified forms or cut from a massive block, Additive Manufacturing bases on the principle that liquids, powders, stands and films are layered to build 3D-structures without the use of a mould. It refers to the process of joining materials to manufactured objects, usually layer upon layer, as opposed to “subtractive manufacturing” methods, such as machining. 3D Printing is a synonym often used for Additive Manufacturing and summarizes various technologies and ways of using this technology.

Figure 1. Hype Cycle for 3D Printing, 2014

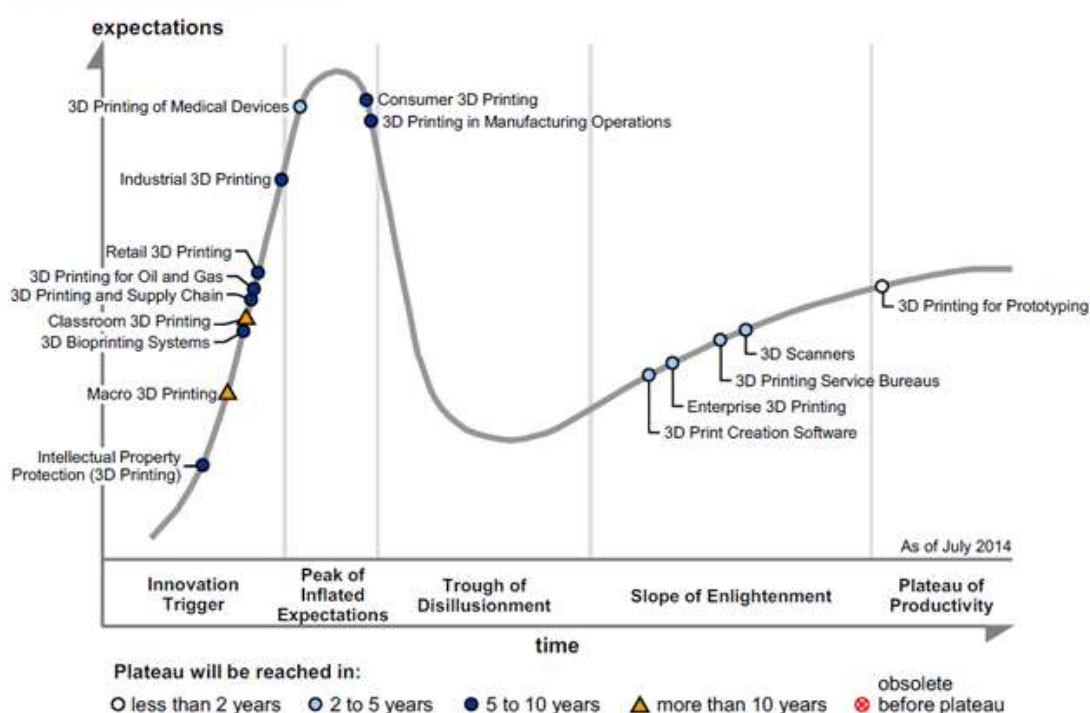

Source: Gartner 2014

ISO and ASTM International signed a Partner Standards Development Organization (PSDO) cooperation agreement in 2011 to increase their cooperation in the development of International Standards for additive manufacturing. The decision to set up the PSDO agreement followed the creation of ISO technical committee ISO/TC 261, Additive manufacturing. ASTM's committee F42, Additive manufacturing technology, already had important work in this area and it was decided that both groups would benefit from combining their expertise. Internal liaisons have been initiated with ISO/TC 61, ISO/TC 61/SC 9, ISO/TC 106, ISO/TC 106/SC 9, ISO/TC 119, ISO/TC 184, ISO/TC 213 and IEC/TC 76.

The main objectives of ISO/TC 261 are to standardize the processes of Additive Manufacturing, their process chains (Hard- and Soft- ware), test procedures, quality parameters, supply agreements, fundamentals and vocabularies. It is agreed by all member bodies that those objectives always have to follow the market needs and enable flexible reaction on changes.

Structure of AM Standards

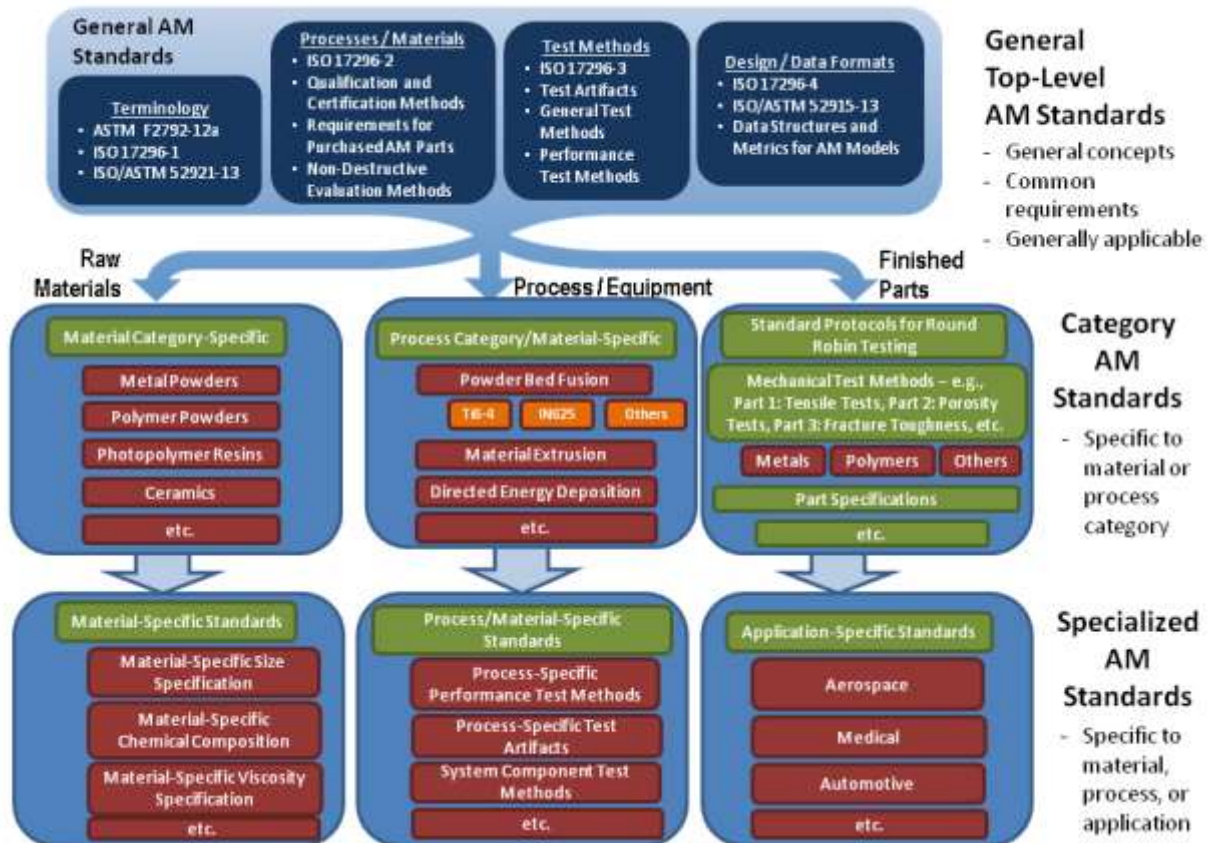

Taken from ISO/TC 261 Business Plan 06/08/2015

The main consumer issues in this area relate to consumer product safety for products that may be manufactured using 3D printing technology. Before the standards development work becomes advanced in this area, now would be good timing to raise consumer safety concerns to the ISO/TC 261 committee. The key consumer objective is to include these consumer safety requirements in current projects; this objective is pending.

Please note that there will be a distinction between:

- Current TC 261 work – keep in Key Areas WG (this template)
 - The 3D printing design community will need to take the initiative in ensuring consumer safety is integral to product design.
- New items for consumers in the Product Safety WG (different template)
 - COPOLCO could seek to include:
 - safety of raw materials, 3D printer use and product outputs within ISO/TC 261’s scope or propose a separate project.
 - Develop and adapt product safety education and guidance materials suitable for 3D print designers and producers.
 - Recommendation that the 3D printing design community should establish forums for conferring and collaborating with one another and other product practitioners on safe design.

20.2.2. Standards work

Committee	Working draft or standard	Progress or change during reporting year Any action to be taken
ISO/TC 261	ISO 17296-2:2015 Additive manufacturing – General principles – Part 2: Overview of process categories and feedstock	60.60 Published Standard
ISO/TC 261	ISO 17296-3:2014 Additive manufacturing – General principles – Part 3: Main characteristics and corresponding test methods	60.60 Published Standard
ISO/TC 261	ISO 17296-4:2014 Additive manufacturing – General principles – Part 4: Overview of data processing	60.60 Published Standard
ISO/TC 261	ISO/ASTM 52900:2015 Additive manufacturing – General principles – Terminology	60.60 Published Standard
ISO/TC 261	ISO/ASTM 52915:2016 Specification for Additive Manufacturing File Format (AMF) Version 1.2	60.60 Published Standard
ISO/TC 261	ISO/ASTM 52921:2013 Standard terminology for additive manufacturing – Coordinate systems and test methodologies	60.60 Published Standard
ISO/TC 261	ISO/ASTM DIS 52901 Additive manufacturing – General principles – Requirements for purchased AM parts	40.60 DIS - Close of voting
ISO/TC 261	ISO/ASTM NP 52902 Additive manufacturing – General principles – Standard test artefacts	10.99 Proposal stage - New project approved
ISO/TC 261	ISO/ASTM DIS 52903-1 Additive Manufacturing – Standard Specification for Material Extrusion Based Additive Manufacturing of Plastic Materials – Part 1: Feedstock materials	40.20 DIS ballot initiated: 3 months

ISO/TC 261	ISO/ASTM CD 52903-2 Additive manufacturing – Standard specification for material extrusion based additive manufacturing of plastic materials – Part 2: Process – Equipment	30.99 CD approved for registration as DIS
ISO/TC 261	ISO/ASTM DIS 52910 Standard Practice – Guide for Design for Additive Manufacturing	40.99 Full report circulated: DIS approved for registration as FDIS

20.2.3. Relevant links

The committee website is located at:

http://www.iso.org/iso/home/standards_development/list_of_iso_technical_committees/iso_technical_committee.htm?commid=629086

Committee liaisons to ISO/TC 261:

- ISO committees in liaison include ISO/TC 44, ISO/TC 44/SC 14, ISO/TC 119, ISO/TC 150, ISO/TC 184/SC 1, ISO/TC 184/SC 4
- IEC committees in liaison include IEC/TC 76 Optical radiation safety and laser equipment

Committee liaisons from ISO/TC 261:

- ISO committees in liaison include ISO/TC 44, ISO/TC 61, ISO/TC 61/SC 9, ISO/TC 106, ISO/TC 106/SC 9, ISO/TC 119, ISO/TC 184, ISO/TC 213
- IEC committees in liaison include IEC/TC 76 Optical radiation safety and laser equipment

http://www.iso.org/iso/home/standards_development/list_of_iso_technical_committees/iso_technical_committee.htm?commid=629086

ISO Article on work of ISO/TC 261: <http://www.iso.org/iso/news.htm?refid=Ref1956>

20.2.4. Information of meetings and consumer participation

Committee	Date of last meeting	Date of next meeting	WG/ Standard(s)	Consumer representative(s) in the key area
ISO/TC 261	unknown	14 July 2016 in Tokyo	Current program listed above	n/a

A Joint ISO/ASTM Steering Group has been established to monitor the progress and report on the status of the joint groups, resolve any problems, present proposals for joint activities to the respective plenary groups, and maintain a three-year plan for joint standards development. The Joint Steering Group conducts virtual meetings twice per year (in spring and autumn – northern hemisphere) to be scheduled between the fixed ISO/TC 261 and ASTM F42 plenary meetings. The group may also take the opportunity to meet face-to-face at meetings of ISO/TC 261 or ASTM F42.

20.2.5. Key person

For further information, please contact: Alison Scotland, Alison.scotland@standards.org.au, Standards Australia.

20.3. Fine Bubble Technology

20.3.1. Summary

Fine Bubble Technology is a new technology that adds ultra-fine bubbles smaller than the wavelength of light to water. It has increasing applications in a range of industries such as cleaning, sterilisation, agriculture, fisheries, food production, beverages, medical, pharmaceutical, cosmetics and healthcare.

ISO/TC 281's main objectives are to create international standards in the field of Fine Bubble Technology covering general principles including terminology, characterization and applications of fine bubbles of gas in a typically but not exclusively liquid medium. The artificially manufactured fine bubbles of typically smaller than 100 micrometres in size are considered.

The main consumer issue relates to consumer product safety for products and processes using fine bubble technology. Before the standards development work becomes advanced, now would be a good timing to raise consumer safety concerns to the ISO/TC 281 committee to consider in their future projects for fine bubble technology applications. The key consumer objective is to prepare the committee to consider consumer principles and rights for future work; this objective is pending.

Current TC 281 work is generally only related to the measurement of fine bubbles and characterisation for now, with less on the application side. Once work progresses with this committee, it might be worth submitting a new template for monitoring in the Product Safety Working Group (different template), such as:

- Safety of fine bubble technology applications.
- Consumer awareness of fine bubble technology – similar to that of nanotechnology.

20.3.2. Standards work

Committee	Working draft or standard	Progress or change during reporting year Any action to be taken
ISO/TC 281	ISO/CD 20480-1 Fine bubble technology – General principles for usage and measurement of fine bubbles – Part 1: Terminology	30.60 CD - Close of voting/ comment period.

20.3.3. Relevant links

The committee website is located at:

http://www.iso.org/iso/iso_technical_committee?commid=4856666

Committee liaisons to ISO/TC 281:

- ISO committees in liaison includes ISO/TC 24/SC 4 Particle characterization

Committee liaisons from ISO/TC 281:

- ISO committees in liaison includes ISO/TC 24/SC 4

http://www.iso.org/iso/iso_technical_committee?commid=4856666

ISO Article on work of ISO/TC 281:

http://www.iso.org/iso/home/news_index/news_archive/news.htm?refid=Ref1844

20.3.4. Information of meetings and consumer participation

Committee	Date of last meeting	Date of next meeting	WG/ Standard(s)	Consumer representative(s) in the key area
ISO/TC 281	19 October 2015	26-27 July 2016 in Sydney	Current program listed above	n/a
ISO/TC 281	-	24-25 November 2016 in London	TBC	n/a

20.3.5. Key person

For further information, please contact: Alison Scotland, Alison.scotland@standards.org.au, Standards Australia.

21. Protection of Personal Data

21.1. Summary

The key consumer concerns remain as last years' report. However, now specific guidance is becoming available to guide consumer representatives on these issues, as reported below.

Key concerns

- **The role of domestic personal processing** which is explicitly excluded from most Data Protection legislation, as opposed to organisational processing which is included.

Notes:

- *Although the distinction between personal and organisational processing has been identified for many years, current standards address only data protection/organisational processing in any depth.*
- *The rise of the Smartphone and its "apps" has brought the need for this to be addressed urgently to the fore with over ~ 2 billion Smartphones in use across the developed and developing world, having risen to this figure with the introduction of the iPhone in 2007. Since then consumers have been living with the Internet of Things accessed via smart phone apps for ~ 9 years.*

- **The individual's privacy control over automated data collection** especially where this occurs as part of pervasive processing and sensing solutions. This is starting to be seen, or be planned, for a good number of consumer environments (street cameras, smart meters, location services and so on).

- **3rd party processing** where data sharing leads to issues of where an individual's data is being used, by whom, and for what purpose. Addressing the tracking of data sharing and subsequent use of shared data is weak in current standards.

- **The use of large scale data analytics** creating high levels of identifiability from anonymous data.

As in previous reports, concerns still exist for:

- Ensuring good quality privacy impact assessment;
- 'Privacy by design' to ensure current technologies maximize privacy from the beginning. Two key areas are RFID and Smartphones;
- Privacy-enhancing technologies to gain much supplementary protection if privacy cannot be inherently designed in;
- Standards that cater for people's natural behaviour (behavioural economics) to protect the public from exploitative practices and technologies;
- Consumers as data controllers – where through Smartphone apps, blogs, social networking sites etc. personal processing is undertaken and where maximum privacy by default should be aimed for;
- Proportionality of use of data especially by the public sector.

21.2. Standards work

Committee	WG / Standard(s) affected	Issue addressed / Progress or change reported
UK BSI – IST 33, 34 and ICT 1	<p>Internet of Things, Big Data, Smart Cities and the range of technical committees dealing with digitised goods and services used or purchased by consumers.</p> <p>ISO Privacy standards</p>	<p><u>Issues:</u></p> <p>Coordination of consumer representation with respect to key digital issues across 100s of technical committees.</p>
<p>Privacy by Design</p> <p>ANEC (The European consumers voice in standardisation)</p> <p>and</p> <p>BSI Consumer and Public Interest Network</p> <p>and CEN TC 225</p>	<p>CEN/CENELEC WG8</p> <p>The ANEC work is key input to the UK BSI ICT consumer coordination issues</p> <p>TC 225 is keen to see other EU standards build on the foundation work of the RFID privacy impact assessment standard EN 16571 and public notification, labelling and consumer information standard EN 16570.</p> <p><i>The significance of these standards is dealt with in the associated ANEC report.</i></p>	<p>ANEC preparation for the EU’s M530 projects (when finalised and agreed) on Privacy by Design.</p> <p>Background: A core team has been set up by a CEN/CENELEC joint working group (WG8) to identify and plan and cost the deliverables to be provided for M530. The planning work is still in progress at the time of this report. To support ANEC’s contribution the following was undertaken over the last year:-</p> <ul style="list-style-type: none"> • Analysis of the design process within the ISO 9000 framework of plan, do, check, act <p>and</p> <ul style="list-style-type: none"> • Investigation of relevant ISO standards that could contribute <p>For progress on these topics see the associated ANEC report.</p>
ISO COPOLCO Consumer Privacy	<p>BSI-CPIN / ANEC consumer representative privacy guides</p> <p>COPOLCO consumer privacy needs statement</p> <p>COPOLCO privacy needs strategic gap analysis</p>	<p>Issues: Training and support to consumer reps on digital privacy</p> <p>In May 2015 at COPOLCO’s annual plenary in Geneva the UK and EU work on privacy guides for consumer representatives was presented with copies of the guides available to delegates. This resulted in:</p> <ul style="list-style-type: none"> • Adoption of the BSI-CPIN / ANEC privacy guides with a commitment

		<p>to add to them any developing economy privacy factors not already dealt with in the guides.</p> <ul style="list-style-type: none"> • A resolution to produce a privacy gaps analysis of ISO standards to be undertaken by PE. • A later request to PE to produce (from the guides) a list of consumer privacy needs. <p>Consumer representatives support: Although no formal request has been made to identify what consumer rep training might be required voluntary work is being undertaken by 3 individual consumer standards experts from BSI-CPIN, CI and ANEC to try to identify what should be provided.</p> <p>Privacy gap analysis: PE undertook this task making use of a Smart Cities report for JTC 1 produced by its Smart Cities Group which was examining standards gaps in that domain. Given how wide ranging the topic is, the Smart Cities report enabled a high level privacy gap analysis to be undertaken by making use of that JTC 1 comprehensive look across ICT standards for Smart Cities.</p> <p>The main gaps of</p> <ul style="list-style-type: none"> • domestic privacy / the Internet of Things, • data sharing and trading transparency • identifiability and anonymization <p>were confirmed and agreed to be communicated by COPOLCO.</p> <p>Privacy needs – a needs list has been produced for COPOLCO as a document of sufficient quality for the needs list to be communicated to the rest of ISO. The significance of the needs list is described in the associated ANEC report that covers privacy by design work.</p>
ISO COPOLCO	Consumer representation	At the May 2015 COPOLCO Plenary a resolution was passed to seek a dialogue with JTC 1 to achieve more effective consumer representation and participation in ISO ICT standards development.

		<p>During July 2015 PE produced a coordination and representation analysis (as PowerPoint presentation) for COPOLCO that, in the sample case of privacy, identified:</p> <ul style="list-style-type: none"> • 16 out of 30 JTC 1 Sub Committees (SC's) and Study Groups (SG's) involved with consumer privacy issues • 62 non JTC 1 ISO Technical Committees (TC's) responsible for consumer goods and services where 'doing digital' and hence privacy was relevant • 31 non JTC 1 ISO Technical Committees (TC's) responsible for services that were potential users of personal data collected by 3rd parties. <p>COPOLCO identified from ISO records 24 consumer reps sitting on ISO SC Working Groups with the largest number of these involved in JTC 1's accessibility standards.</p> <p>The COPOLCO resolution re: consumer representation was picked up by the UK (BSI ICT 1 committee) and through them PE was asked to attend and present on the consumer representation issue at the JTC 1 Joint Advisory Group meeting in Paris on 14th March 2016.</p> <p>The proposal to have a COPOLCO consumer representative on the JTC 1 JAG as a starting point for discussing the issues and finding more effective approaches was not accepted (at this stage) and more investigation was asked for.</p> <p>COPOLCO will be producing a paper on the ICT consumer representation issues for the JAG to consider later in 2016.</p>
--	--	---

21.4. Consumer representation in priority area

Committee	WG / Standard(s) affected	Consumer representative(s) (Name, organization, affiliation)
CEN TC 225	WG 3 security and WG 4 application standards for auto-identification.	Peter Eisenegger BSI/ANEC ANEC Privacy and Internet of Things expert
BSI IST 33	IT Security Techniques	Peter Eisenegger BSI
BSI ICT 1	ICT standards coordination	Peter Eisenegger BSI

21.5. Key person

For further information, please contact: Peter Eisenegger, p.eisenegger@btinternet.com, British Standards Institution, Consumer and Public Interest Network

(Page intentionally left blank)

22. Road Vehicle Safety Systems

22.1. Summary

The working group on child restraints has been renamed ISO/TC22/SC36/WG2.

22.2. Standards work

Committee	Working draft or standard	Progress or change during reporting year Any action to be taken
ISO/TC22/SC36 Road vehicles	<p>WG2</p> <p>ISO/TR 13214: 1996, <i>Road vehicles – Child restraint systems – Compilation of safety regulations and standards.</i></p> <p>ISO 13215-1, <i>Road vehicles – Reduction of misuse risk of child restraint systems – Part 1: Forms for field studies of misuse</i></p> <p>ISO 13215-2: <i>Road vehicles – Reduction of misuse risk of child restraint systems – Part 2: Requirements and test procedure for correct installation (panel method).</i></p> <p>ISO 13215-3, <i>Road vehicles – Reduction of misuse risk of child restraint systems – Part 3: Misuse Mode and Effects Analysis (MMEA).</i></p> <p>ISO 13216-1, <i>Road vehicles – Anchorages in vehicles and attachments to anchorages for child restraint systems – Part 1: Seat bight anchorages and attachments (ISOFIX).</i></p> <p>ISO 13218, <i>Road vehicles – Child restraint systems –</i></p>	<p>The ISO standard was published in July 2006 Because of the rapid development of CRS related regulations and web services for keeping track of them, WG 2 proposes to withdraw ISO/TR 13214:1996. SC 36 is asked for approval of the resolution.</p> <p>The standard was published in 2006 and confirmed at systematic reviews.</p> <p>ISO 13215-2 was published in 1999 and confirmed in the second systematic review that took place in 2012.</p> <p>ISO 13215-3 was published in 1999 and confirmed in the second systematic review that took place in 2012.</p> <p>The ISO standard was published in December 1999, and was later implemented in FMVSS, CMVSS, ECE R14 and R44. It has recently been implemented also in the AS/NZS standards.</p> <p>The ISO standard was published in August 1998.</p>

	<p><i>Report form for accidents involving child passengers.</i></p> <p>ISO/PAS 13396, <i>Road vehicles – Sled test method to enable the evaluation of side impact protection of child restraint systems – Essential parameters.</i></p> <p>ISO 13216-1:1999/Amendment 1, <i>Road vehicles – Anchorages in vehicles and attachments to anchorages for child restraint systems – Part 1: Seat bight anchorages and attachments – Amendment 1: CRF reduced height specifications.</i></p> <p>ISO 13216-1:1999/DAmD 2, <i>Road vehicles – Anchorages in vehicles and attachments to anchorages for child restraint systems – Part 1, Draft Amendment 2, Tolerance specifications.</i></p> <p>ISO 13216-1:1999/Amendment 3, <i>Road vehicles - Anchorages in vehicles and attachments to anchorages for child restraint systems – Part 1, Draft Amendment 3, Specifications for the detection of use of ISOFIX CRS in road vehicles.</i></p>	<p>In the second five-year review two countries asked for revision and one country asked for a minor update/-correction. This update is well justified, however due to lack of input and resources it has not started yet.</p> <p>Because of the ISO lifetime for a PAS of 6 years, WG 2 agreed to ask for an upgrade to Technical Specification of the current ISO/PAS 13396:2009, without changing the contents. WG 2 is interested to start a preliminary review to possibly update the contents in the future, based on more recent experiences.</p> <p>The specification refers to the positioning fixture for seating positions that cannot accommodate the full-size CRF fixture. Amendment 1 was published in February 2006.</p> <p>In progress.</p> <p>Amendment 3 was published in August 2006.</p>
--	---	---

	<p>ISO 13216-2, <i>Road vehicles – Anchorages in vehicles and attachments to anchorages for child restraint systems – Part 2: Top tether anchorages and attachments.</i></p> <p>ISO 13216-3, <i>Road vehicles – Anchorages in vehicles and attachments to anchorages for child restraint systems – Part 3: Classification of child restraint dimensions and space in vehicle.</i></p> <p>ISO/WD 13215-4, <i>Road vehicles – Reduction of misuse risk of child restraint systems – Part 4: Instructions and labels.</i></p> <p>ISO/TS 22239 <i>CPOD status,</i></p> <p>ISO/DTR 29061-2, <i>Road vehicles – Methods and criteria for usability evaluation of child restraint systems and their interface with vehicle anchorage systems – Part 2: Manual to assist the usability assessments of ISO 29061-1</i></p> <p>ISO/WD 29061-3, <i>Road vehicles – Methods and criteria for usability evaluation of child restraint systems and their interface with vehicle anchorage systems – Part 3: Installation of child restraint systems using vehicle seat belts.</i></p>	<p>The systematic review in 2013 confirmed the standard.</p> <p>The ISO standard was published in October 2006. The contents of ISO 13216-3 were adopted in UN (ECE) R16. WG 2 has started the revision work to include the booster seat and R2X envelopes/fixtures, and to further improve the standard</p> <p>WG 2 asks for the publication of the revised parts as ISO Technical Specifications, instead of an International Standard. SC 36 is asked for approval of the resolution</p> <p>The three DIS versions will soon be submitted to SC 36 for voting.</p>
--	---	---

	<p>ISO/WD 29061-4, Road vehicles – Methods and criteria for usability evaluation of child restraint systems and their interface with vehicle anchorage systems – Part 4: Securing of child in child restraint system and daily handling aspects</p> <p>ISO/WD 29061-5, Road vehicles – Methods and criteria for usability evaluation of child restraint systems and their interface with vehicle anchorage systems – Part 5: Installation and securing of child in a booster seat.</p> <p>ISO/TS 29062, Child restraints side impact</p>	<p>WG 2 agreed to ask for a revision work item of ISO/TS 29062. The revision would consider the current UN-ECE R129 test setup and other existing test methods, the latest available real world data, and also look at the possibility to address further body regions.</p>
--	---	---

22.3. Relevant links

ISO/TC 22 home page

http://www.iso.org/iso/home/standards_development/list_of_iso_technical_committees/iso_technical_committee.htm?commid=46706

22.4. Information of meetings and consumer participation

Committee	Date of last meeting	Date of next meeting	WG/ Standard(s)	Consumer representative(s) in the key area
<p>ISO/TC 22/SC36 Road vehicles</p>	<p>Last meeting of ISO/TC22/SC36/WG2 was held in Paris in June 2015 and in Munich in November 2015</p>	<p>Spring 2016</p>	<p>WG 2 Child restraint systems</p>	<p>D: Henry Görlitz Stiftung Warentest Usability: UK: representing BSI-CPC Mike Hayes Child Accident Prevention Trust</p>

22.5. Key person

For further information, please contact: Helen Amundsen, HA@fbr.dk, Danish Consumer Council.

23. Road Transport

23.1. Road traffic safety management systems

23.1.1. Summary

ISO has many standards to help make roads safer. Ranging from specifications for wheels, braking systems and road holding ability, to crash protection, child restraint systems and ergonomics. Many aim to improve compatibility, interchangeability and safety, or to provide the test procedures for evaluating performance.

With the world's first integrated traffic management standard, **ISO 39001**, published in 2012, ISO has taken an important step to help prevent road deaths around the world as part of the United Nations Decade of Action for Road Safety 2011-2020, and in line with work at the national level.

ISO's Acting Secretary General presented at a road safety panel at CI's World Congress. This year Consumers International have launched a global campaign to reduce the number of road crash fatalities, #StopTheCrash. It argues safer vehicles are urgently needed to help reduce the 1.25 million deaths that occur every year. CI is working with the Global New Car Assessment Program (GNCAP) and regional NCAPs to raise awareness around new technologies that help prevent accidents happening, and calling for the adoption of regulations by governments and car manufacturers to ensure every car in every market meets at least basic safety features and universally-recognized standards.

To support the application of the new standard, there is also now an audit standard and a number of programs for accreditation and certification.

The ongoing focus of the TC is promoting global awareness and application of the standard. Some activities include:

- establishing a marketing committee
- collecting case studies
- developing materials for academia and in-service practitioners
- increasing participation from developing and low/medium income countries
- identifying champions for the standard to the private sector (as part of CSR)

23.1.2. Standards work

Committee	WG / Standard(s) affected	Issue addressed / Progress or change reported
TC 241 – Road Traffic safety management systems	ISO 39001:2012 specifies requirements for a road traffic safety (RTS) management system to enable an organization that interacts with the road traffic system to reduce death and serious injuries related to road traffic crashes which it can influence.	Focus is on building awareness of this new MSS and encouraging organizations and nations to implement the standard. ISO 39001 is a relevant “ingredient” of United Nations Road Safety (UNRSC) Working Group 1 which deals with Pillar 1 – Road Safety Management. UNRSC will also support UN GA regarding the work this week for an updated Road Safety resolution.

		<p>There is wide spread of the standard and more developing countries are getting involved in the work in the TC and applying ISO 39001. However, one concern is the difficulty to obtain information regarding ISO 39001 and to have more information on certification (country, sector, number, and accreditation).</p> <p>There is a call for more participation by developing countries and DEVCO.</p>
	ISO 39002 , Good practices for implementing commuting safety management	Work has started on this new item.

23.1.3. Relevant links

On the road to safety ISO Focus+ special issue

http://www.iso.org/iso/main-focus_oct2009.pdf

<http://www.decadeoraction.org>

http://www.who.int/roadsafety/decade_of_action/en/index.html

<http://www.grsroadsafety.org/>

<http://www.consumersinternational.org/our-work/car-safety/>

ISO road safety standard could help save thousands of lives

<http://www.iso.org/iso/news.htm?refid=Ref1661>

ISO/TC 241 Road traffic safety management systems

http://www.iso.org/iso/iso_technical_committee?commid=558313

ISO standards support UN Decade of Action for Road Safety

<http://www.iso.org/iso/news.htm?refid=Ref1426>

23.1.4. Date of information and meetings

No information provided.

23.1.5. Key person

For further information, please contact: Dr Kwei Quaye, kquaye@sgi.sk.ca, Traffic Safety and Driver Services, SGI, Canada.

23.2. Electric road vehicles and electric trucks

23.2.1. Summary

Considerable safety standards and protocols are being developed related to the supply, charging and storage of electricity for electric vehicles (EV) at the national, regional and international level. It is important that countries participate at the international level and work towards harmonization and adoption of standards in order to minimize international trade barriers to EV adoption.

At the national level standards work includes projects to deliver a series of safety standards and protocols related to the supply, charging and storage of electricity for electric vehicles (EV) in Canada.

To date we have enhanced Canada's participation in the development of EV codes and standards through three approaches. The first is the establishment and updating of the Canadian Electrical Code for Electric Vehicle Supply Equipment (EVSE) which published in January of 2015. The second is the development and harmonization of EVSE product requirements for North America which is currently updating four tri-national standards with USA and Mexico. The third is the participation, establishment, harmonization, and adoption of standards at an international level, in order to minimize international trade barriers to EV adoption. These activities have and will allow Canada to leverage the technical expertise of the international community and establish Canada as a leader in the global EV community.

23.2.2. Standards work

Committee	Working draft or standard	Progress or change during reporting year Any action to be taken
C232(280).1T Wireless Power Transfer (WPT) Equipment for Electric Vehicles	<ul style="list-style-type: none"> - C22.2 No. 61980-1: Electric vehicle wireless power transfer systems (WPT) Part 1: General requirements - C22.2 No. 317: Wireless Power Transfer (WPT) Equipment for Electric Vehicles - E62660-1 (Secondary lithium-ion cells for the propulsion of electric road vehicles – Part 1: Performance testing) - E62660-2 (Secondary lithium-ion cells for the propulsion of electric road vehicles – Part 2: Reliability and abuse testing) 	<ul style="list-style-type: none"> - Ballot Disposition phase. - Currently in content development - Published: April 2015 - Published: April 2015
C232 (280) Electrical Vehicle–Supply Equipment Note: All four standards are tri-national documents (Canada, USA, and Mexico)	<ul style="list-style-type: none"> - C22.2 No. 280–13: Electric vehicle supply equipment - C22.2 No. 281.1–12: Standard for safety for personnel protection systems for electric vehicle 	<ul style="list-style-type: none"> - in content development - in content development

<p>IEC/TC69 Electric road vehicles and electric industrial trucks</p>	<p>(EV) supply circuits: General requirements</p> <ul style="list-style-type: none"> - C22.2 No. 281.2-12: Standard for safety for personnel protection systems for electric vehicle (EV) supply circuits: Particular requirements for protection devices for use in charging systems - C22.2 No. 282– 13: Plugs, receptacles, and couplers for electric vehicles - IEC61851 Series: Electric vehicle conductive charging system - IEC61980: Electric vehicle wireless power transfer (WPT) systems - IEC60718: Electrical equipment for the supply of energy to battery-powered road vehicles 	<ul style="list-style-type: none"> - in content development - in content development <p>WG 4 – Power supplies and chargers: Revision of IEC 60718</p> <ul style="list-style-type: none"> - Connection of the vehicle to the AC supply - Connection of the vehicle to off-board charge including buffer batteries - Road side energy supply - EMC - Functional safety - Plugs and sockets - Additional supply to the vehicle for heating, cooling, etc. - Communication between the battery and the charger - Inductive coupling for battery charging <p>MT 5 – DC Charging: - Maintenance of 61851-23 and - 24</p> <p>JPT 61980 – Electric vehicle wireless power transfer (WPT) systems: Part 1: General requirements - Part 2: specific requirements for communication between electric road vehicle (EV) and infrastructure with respect to wireless power transfer (WPT) systems - Part 3: specific requirements for the magnetic field power transfer systems.</p>
--	--	--

<p>IEC/TC23/SC23H Plugs, Socket-outlets and Couplers for industrial and similar applications, and for Electric Vehicles</p>	<p>- IEC 62196-2: Specific requirements for communication between electric road vehicle (EV) and infrastructure with respect to wireless power transfer (WPT) systems</p>	<p>JPT 61851-3 – Electric vehicle conductive power supply systems:</p> <ul style="list-style-type: none"> - Part 3-1: General Requirements for Light Electric Vehicles (LEV) AC and DC conductive power supply - Part 3-2: Requirements for Light Electric Vehicles (LEV) DC off-board conductive power supply systems - Part 3-3: Requirements for Light Electric Vehicles (LEV) battery swap systems - Part 3-4: Requirements for Light Electric Vehicles (LEV) communication <p>- PT 62196-4 - Dimensional compatibility and interchangeability requirements for a.c., d.c. and a.c./d.c. vehicle couplers for Class II or Class III light electric vehicles (LEV)</p> <ul style="list-style-type: none"> - To develop the relevant standards in the IEC 62196 series - MT 8 – Maintenance of Plugs, socket-outlets, vehicle connectors and vehicle inlets - Conductive charging of electric vehicles: <ul style="list-style-type: none"> - Maintenance of IEC 62196-1 - Part 1: General requirements - Maintenance of IEC 62196-3 - Part 3: Dimensional compatibility and interchangeability requirements for d.c. and a.c./d.c. pin and contact-tube vehicle couplers.
--	--	--

23.2.3. Relevant links

ISO/TC 241 Road traffic safety management systems

http://www.iso.org/iso/home/standards_development/list_of_iso_technical_committees/iso_technical_committee.htm?commid=558313

IEC/TC 69 Electric road vehicles and electric industrial trucks

http://www.iec.ch/dyn/www/f?p=103:23:0:::FSP_ORG_ID,FSP_LANG_ID:1255,25

IEC link to TC SC23H: Plugs, Socket-outlets and Couplers for industrial and similar applications, and for Electric Vehicles:

http://www.iec.ch/dyn/www/f?p=103:7:0:::FSP_ORG_ID:1426

Current CSA standards work is published to committee members only on the CSA Group Community of Interest Workspace. Upon completion of a draft standard it will be displayed for 60 days for public review at which time comments can be submitted for consideration by the affected committee. As standards publish they will be available on the CSA Group Web Store <http://shop.csa.ca/en/canada/page/home>.

23.2.4. Date of information and meetings

Committee	Date of last meeting	Date of next meeting	WG/ Standard(s)	Consumer representative(s) in the key area
C232(280).1T - Wireless Power Transfer (WPT) Equipment for Electric Vehicles	2016/02/25	2016/04/07	C22.2 No. 317: Wireless Power Transfer (WPT) Equipment for Electric Vehicles	

23.2.5. Key person

For further information, please contact: Peter Glowacki, peter.glowacki@csagroup, CSA Group Canada.

24. Safety of Toys

24.1. Summary

Global alignment is still on ISO TC 181's agenda, with work shared between ISO and CEN. For safety, it is good to have a global standard for toys. But consumer representatives must be aware that requirements are not being relaxed in doing so. The task group comparing the three standards, ISO 8124 part 1, EN 71 part 1, and ASTM F963 (parts on mechanical and physical properties), has prepared a technical report. The TC will have to decide how to publish this, and how to further align the standards.

24.2. Standards work

Committee	Working draft or standard	Progress or change during reporting year Any action to be taken
ISO/TC181 Safety of toys/ WG1	ISO 8124-1 DAMD 1, Safety of toys – Part 1: Safety aspects related to mechanical and physical properties regarding “Cords”	The draft will soon be sent out for a three month DIS ballot
	ISO 8124-1 DAMD 2, Safety of toys – Part 1: Safety aspects related to mechanical and physical properties regarding “Various”	The draft will soon be sent for a three month DIS ballot
	ISO 8124-1 DAMD 3, Safety of toys – Part 1: Safety aspects related to mechanical and physical properties regarding “Warnings and fibrous filling materials”	The draft will soon be sent for a three month DIS ballot
	ISO 8124-1 DAMD 4, Safety of toys – Part 1: Safety aspects related to mechanical and physical properties” regarding “Acoustics”	The draft will soon be sent out for a three month DIS ballot
	IEC 62115 Electrical toys	The revised draft of 62115 was circulated as a CD for comments in TC 61. The comments have been resolved during the TC 61 meeting in June 2015. A second CD was circulated in July 2015. The comments to this CD2 were discussed during the TC 61

		meeting held in the US in November 2015. The revision has now been circulated as a CDV from February to May 2016.
--	--	---

24.3. Relevant links

ISO/TC 181 homepage

http://www.iso.org/iso/home/standards_development/list_of_iso_technical_committees/iso_technical_committee.htm?commid=54044

24.4. Date of information and meetings

Committee	Date of last meeting	Date of next meeting	WG/ Standard(s)	Consumer representative(s) (Name, organisation/ affiliation) involved in the key area
ISO/TC 181 Safety of toys	Beijing in October 2015	Berlin in October 2016	WG 1 ISO 8124-1 ISO 8124-4 ISO 8124-8	DK: Helen Amundsen Forbrugerradet Box 2188 1017 Copenhagen K Denmark Tel +45 77 41 77 41 Fax +45 77 41 77 42 ha@fbr.dk CI: Antonio Bonacruz Australian Consumer's Association (ACA) 57 Carrington Road Marrickville NSW 2204 Australia Tel +61 2 95 77 33 43 Fax +61 2 95 77 32 11

24.5. Key person

For further information, please contact: Helen Amundsen, HA@fbr.dk, Danish Consumer Council.

25. Second-hand Goods

25.1. Summary

ISO/CD 20245 is out for ballot with the committee. If approved it will then proceed to ISO/DIS 20245 and then be completed as an International Standard.

ISO/TS 20245 and the work of ISO/PC 245 were presented at ISO/COPOLCO's 2015 Training Workshop. ISO/PC 245's work was also presented at ICSPHO Conference in Denmark in October 2015 in the discussion on 'Circular Manufacturing'.

Products produced using Circular Manufacturing and leased products are being considered at the CD and DIS stage of ISO 20145.

25.2. Standards work

Committee	Working draft or standard	Progress or change during reporting year Any action to be taken
ISO PC 245	ISO CD 20245	Currently the international standards project is at the CD ballot stage. The CD is a revision to ISO TS 20245 which incorporates clarification, refers to the Basel Convention, UN/CE Fact requirements. The ballot will close in April 2016 which will then lead to disposition of comments. It is intended to hold a meeting of this committee in 2016 but the time and location have not been set.

25.3. Relevant links

http://www.iso.org/iso/iso_catalogue/catalogue_tc/catalogue_tc_browse.htm?commid=562919

<http://www.enviro-solutions.com/dailynews2/041114-iso-20245-goods.htm>

www.iso.org

<http://www.iso.org/iso/home/search.htm?q=ISO+TS+20245&sort=rel&type=simple&published=on>

http://www.iso.org/iso/isofocus_108.pdf

http://www.iso.org/iso/isoupdate_september2014.pdf

<http://www.iso.org/iso/news.htm?refid=Ref1899>

25.4. Date of information and meetings

Committee	Date of last meeting	Date of next meeting	WG/ Standard(s)	Consumer representative(s) in the key area
ISO PC 245	2014/03	TBD	NA	Various from ISO Copolco Members

25.5. Key person

For further information, please contact: Rae Dulmage, rae.dulmage@ul.com, ULC standards and Underwriters Laboratories of Canada.

26. Security

26.1. Product fraud countermeasures and controls

26.1.1. Summary

Counterfeiting and fraud was led by ISO TC 247 fraud countermeasures and control until the end of 2014. From January 2015, TC 292 security initiated its operation by integrating several relevant Technical committees, such as TC 247 and TC 223 societal security. TC 292 now deals with the standardization in the field of security, including but not limited to generate security management, business continuity management, resilience and emergency management, fraud countermeasures and controls, security services, homeland security.

TC 292's newly opened website can be found at <http://www.isotc292online.org>. Now WG 4 deals with the anti-counterfeiting area and has changed its title from 'fraud countermeasures and control' to 'Authenticity, integrity and trust for products and documents'. Consumers are to be key stakeholders as they are potential victims and prevention agents in the fighting against counterfeit. Consumers buy counterfeit goods even if they know they are fake. So how we can support legitimate consumers and users is one of the key issues in ISO 19564. To see more on the real cost of counterfeit to consumers, please read the article [Crackdown on counterfeiting](#).

26.1.2. Standards work

Committee	WG / Standard(s) affected	Issue addressed / Progress or change reported
ISO TC 292 Security and resilience	ISO/DIS 34001, <i>Security and resilience – Security management system – Fraud countermeasures and controls</i>	Stage 40
	ISO/AWI 19564, <i>Security and resilience – Product fraud countermeasures and control – General principles</i>	Stage 20
	ISO/WD 20229, <i>Security and resilience – Guidelines for establishing interoperability among object identification systems to deter counterfeiting and illicit trade</i>	Stage 20
	ISO/NP 19998, <i>Security and resilience – Requirements for the content, security and issuance of excise tax stamps</i>	Stage 10.99

26.1.3. Relevant links

The following is the link to TC 292 security:

<http://www.isotc292online.org/organization/Working-Group-4>

or

http://www.iso.org/iso/home/standards_development/list_of_iso_technical_committees/iso_technical_committee.htm?commid=5259148

Crackdown on counterfeiting ISO Focus article 8 January 2014

<http://www.iso.org/iso/news.htm?refid=Ref1809>

26.1.4. Date of information and meetings

Committee	Date of next meeting	WG/ Standard(s)	Consumer representative(s) in the key area
ISO TC 292	13 April in Paris, France+WebEx	ISO 22311 PT meeting	
ISO TC 292	14 April, WebEx	ISO 22326 PT meeting	
ISO TC 292	14 April, WebEx	AHG Security Management Systems	
ISO TC 292	9 May, Webex	ISO 34001 PT meeting	
ISO TC 292	19 May, WebEx	7th Communication Group meeting	
ISO TC 292	5-9 September in Edinburgh, UK	3rd ISO/TC 292 plenary meeting	
ISO TC 292 WG 1	29 April, Webex		
ISO TC 292 WG 2	25-27 April in Boston (Quincy), USA		
ISO TC 292 WG 4	9-13 May in Seoul, Korea		Hyeon-ho Park
ISO TC 292 WG 6	14-15 April in Paris, France		

26.1.5. Key person

For further information, please contact: Professor Hyeon-ho Park, policesecurity@daum.net, Counter Fraud & Counterfeiting Research Center, Korea.

26.2. Security and resilience

26.2.1. Summary

ISO/TC 292 was established on January 1 in 2015 and is responsible for standardization in the field of security to enhance the safety and resilience of society. At this time the experts involved in TC 292 represent more than 50 National Standards Bodies.

The committee is responsible for more than 20 published International Standards which are of interest to consumers as they provide guidance for the prevention, mitigation, response to and recovery from naturally occurring events, human induced events (both intentional and unintentional) and technology-caused events that can impact an organization, community or society and the environment on which we depend.

26.2.2. Standards work

TC 292 – Security	Working draft or standard	Progress or change during reporting year Any action to be taken
WG 1 – Terminology	ISO 22300 – Terminology Monitors consistency and alignment of working drafts and promotes the use of common terms and definitions in the standards produced by ISO/TC 292 Working Groups. Most have requested the assistance on drafting and terminology. WG 1 leads the User Friendly Standards Initiative to encourage the development of standards that the standard user can understand and apply as the content is clear and concise.	WG 1 is now reviewing all terms and definitions from standards published up to March 2016 for incorporation into the revision of ISO 22300 that should be released for ballot later this year. The next WG 1 meeting will be held April 29 by WebEx
WG 2 – Business continuity management	ISO 22301 Societal security – Business continuity management systems – Requirements ISO 22313 Societal security – Business continuity management systems – Guidance ISO/TS 22317 Societal security – Business continuity management systems – Guidelines for business impact analysis ISO/TS 22318 Societal security – Business continuity management systems – Guidelines for supply chain	The 3rd WG 2 meeting will be held on April 25-27 in Boston (Quincy), USA to work on these projects: ISO 22316 – Guidelines for organizational resilience ISO 22330 – Business continuity management systems – Guidelines for people aspects ISO 22331 – Business continuity management systems – Guidelines for business continuity strategy

	<p>continuity ISO/IEC/TS 17021-6 Conformity assessment – Requirements for bodies providing audit and certification of management systems – Part 6: Competence requirements for auditing and certification of business continuity management systems</p>	
WG 3 - Emergency management	<p>ISO 22320 Societal security – Emergency management – Requirements for incident response ISO 22322 Societal security – Emergency management – Guidelines for public warning ISO 22324 Societal security – Emergency management – Guidelines for colour coded alert ISO/TR 22351 Societal security – Emergency management – Message structure for exchange of information</p>	<p>WG 3 has three ongoing projects: ISO 22320 – Emergency management – Guidelines for incident response (revision) ISO 22325 – Emergency management – Guidelines for capability assessment ISO 22326 – Emergency management – Guidelines for monitoring of facilities with identified hazard</p>
WG 4 - Authenticity, integrity and trust for products and documents	<p>ISO 12931 Performance criteria for authentication solutions used to combat counterfeiting of material goods ISO 16678 Guidelines for interoperable object identification and related authentication systems to deter counterfeiting and illicit trade</p>	<p>The next WG 4 meeting will be held May 9-13 in Seoul, Korea. Two Project Teams are working on new standards: ISO 20229 – Guidelines for establishing interoperability among object identification systems to deter counterfeiting and illicit trade and ISO 19564 – Guidelines for product fraud countermeasures and control</p>
WG 5 - Community resilience	<p>ISO 22315 Societal security – Mass evacuation – Guidelines for planning ISO 22397 Societal security – Guidelines for establishing partnering arrangements ISO 22398 Societal security – Guidelines for exercises</p>	<p>WG 5 is currently developing three new standards: ISO 22319 – Community resilience – Guidelines for planning the involvement of spontaneous volunteers ISO 22395 – Community resilience – Guidelines for supporting community response to vulnerable people ISO 22396 – Community resilience – Guidelines for information sharing between organizations</p>

<p>WG 6 - Protective security</p>	<p>ISO 22311 Societal security – Video-surveillance – Export interoperability ISO 18788 Management system for private security operations – Requirements with guidance for use ISO 28000 Specification for security management systems for the supply chain ISO 28001 Security management systems for the supply chain – Best practices for implementing supply chain security, assessments and plans – Requirements and guidance ISO 28002 Security management systems for the supply chain – Development of resilience in the supply chain - Requirements with guidance for use ISO 28003 Security management systems for the supply chain – Requirements for bodies providing audit and certification of supply chain security management systems ISO 28004 Security management systems for the supply chain – Guidelines for the implementation of ISO 28000 (Part 1-4)</p>	<p>The Project Team responsible for the revision of ISO 22311 will meet on April 13 in Paris, France (WebEx available)</p> <p>The next WG 6 meeting will be held April 14-15 in Paris, France</p>
--	--	---

26.2.3. Relevant links

TC 292 – Security and Resilience has a website available by following this link:

www.isotc292online.org

26.2.4. Information of meetings and consumer participation

Committee	Date of last meeting	Date of next meeting	WG/ Standard(s)	Consumer representative(s) in the key area
ISO TC 292 – Security and Resilience	ISO/TC 292 – 2nd Plenary and Working Group meetings hosted by BSN 30 November to 4 December, 2015 in Bali, Indonesia, 140 delegates participated representing more than 20 countries.	The 3rd ISO/TC 292 Plenary and Working Group meetings will be held on September 5-9 in Edinburgh, UK, hosted by BSI.	See Section 2	Norma McCormick

26.2.5. Key Person

For further information, please contact: Norma McCormick, normachw@mymts.net, Corporate Health Works, Canada.

27. Services – Energy Services

27.1. Summary

The ISO 50007 committee draft was discussed in depth at the WG 5 meeting in San Francisco in September 2015. Consumers International (CI) redrafted the text substantially both before and after the WG meeting. The standard was drafted for DIS stage and went out for the vote with a closing date of April 18th, 2016. A further meeting of the WG 5 is scheduled for June in Stockholm to coincide with the TC 242 meeting. CI do not have the funds to attend.

ISO 50007 DIS has been approved, with 30 countries voting (of which 27 P-members), a 93% approval rate with 27 positives (25 P-members), 2 negatives, and 21 abstentions (18 P-members).

CI's expert Robin Simpson submitted important comments to the DIS including proposals for energy Ombudsmen and measures against mis-selling for the WG consideration.

27.2. Standards work

Committee	WG / Standard(s) affected	Issue addressed / Progress or change reported
ISO/TC 242 Energy management	WG 5 ISO 50007 Guidelines for the assessment and improvement of energy services to users	The DIS was approved on April 20.

27.3. Relevant links

ISO/TC 242 Energy management homepage

http://www.iso.org/iso/home/standards_development/list_of_iso_technical_committees/iso_technical_committee.htm?commid=558632

27.4. Date of information and meetings

Committee	Date of last meeting	Date of next meeting	WG/ Standard(s)	Consumer representative(s) involved in the key area
TC 242	September 2015	June 2016	WG 5	Robin Simpson, CI

27.5. Key person

For further information, please contact: Robin Simpson, rsimpson@consint.org, Consumers International.

(Page intentionally left blank)

28. Services – Financial services (mobile banking and payments)

28.1. Summary

The ISO 12812 DIS failed by one vote to get adopted at the DIS stage and so a second ballot is being called with the framework document going forward as an IS and the remaining four documents as technical standards.

28.2. Standards work

Committee	WG / Standard(s) affected	Issue addressed / Progress or change reported
ISO/TC 68 Financial Service SC 7 Core banking	WG 10 Mobile /Banking Payment Systems	The working group is responsible for the development of ISO 12812-series
ISO/TC 68 Financial Service SC 7 Core banking	ISO/DIS 12812-1 Core banking – Mobile financial services – Part 1: General framework	Ready for enquiry
ISO/TC 68 Financial Service SC 7 Core banking	ISO/DTS 12812-2 Core banking – Mobile Financial Services – Part 2: Security and data protection for mobile financial services	Will be published as a Technical Specification when finished
ISO/TC 68 Financial Service SC 7 Core banking	ISO/DTS 12812-3 Core Banking – Mobile Financial Services – Part 3: Financial application lifecycle management	Will be published as a Technical Specification when finished
ISO/TC 68 Financial Service SC 7 Core banking	ISO/DTS 12812-4 Core Banking – Mobile Financial Services – Part 4: Mobile payments-to-person	Will be published as a Technical Specification when finished
ISO/TC 68 Financial Service SC 7 Core banking	ISO/DTS 12812-5 Core Banking – Mobile Financial Services – Part 5: Mobile Payments to Business	Will be published as a Technical Specification when finished

28.3. Relevant links

http://www.iso.org/iso/home/standards_development/list_of_iso_technical_committees/iso_technical_committee.htm?commid=49650

28.3. Date of information and meetings

No information provided.

28.5. Key person

For further information, please contact: Robin Simpson, rsimpson@consint.org, Consumers International.

29. Services – Tourism Services

29.1. Summary

ISO TC 228 Tourism and Related Services currently has several active Working Groups:

WG 1 Diving Services
 WG 2 Health Tourism
 WG 7 Adventure Tourism
 WG 8 Yacht Harbours
 WG 11 Bare Boat Charters
 WG 12 International Volunteer Tourism

(An additional Working Group, WG 13 Sustainable Tourism, may be added subject to a ballot due on 4th May 2016.)

These cover a wide range of tourism-related service areas, from facilities provided for recreational sailors in harbours (from 'basic' to 'luxury'), to health spas and thalassotherapy centres.

Key consumer issues mainly relate to ensuring that tourists from all over the world can choose a compliant supplier and be confident of service levels and equipment to match developed countries, whether in a developed country or a developing country seeking to increase tourism as an economic driver. In some cases standards will particularly support safety issues (particularly to assist in countries where tourism is developing but safety standards are not yet as embedded as in, for example, Western Europe). These consumer objectives are key components of the standards being prepared by each of the Working Groups.

All Working Groups and Technical Committee are due to meet 23 – 27 May 2016 in Kuala Lumpur, so any current progress reports will become outdated after that week.

29.2. Standards work

Committee	Working draft or standard	Progress or change during reporting year Any action to be taken
WG 01 Diving Services		Both CEN TC 329 Tourism Services and ISO TC 228 Tourism and related services agreed to develop 2 projects in parallel (under Vienna Agreement): ISO/DIS 11121 Recreational diving services – Requirements for introductory training programmes to scuba diving and ISO/DIS 24803 Recreational diving services – Requirements for recreational scuba diving service providers Both projects will be under ballot (DIS) from 18 February 2016 until 19 May 2016. WG1 will meet in Kuala Lumpur together

<p>WG 02 Health Tourism Services</p>		<p>with the Plenary to deal with the comments received.</p> <p>Little progress has been made since the last meeting in Pretoria (South Africa). Although ANBAL (Spanish Association of Medical Spas) announced their interest to launch a new project for Medical Spas, the proposal is taking more time than expected. Meanwhile, ISO DIS 17679 Wellness spa – Service requirements will soon be ready for publication. This secretariat is waiting to receive the final version of this project to be submitted to ISO.</p>
<p>WG07 Adventure Tourism</p>		<p>The project ISO/AWI 20611 Adventure tourism – Sustainability good practices – Guidance is currently open for comments until 25 February 2016. The group will meet again in Kuala Lumpur (Malaysia) to integrate new contributions and improve the current draft. Portugal as project leader and Brazil in the convenorship and secretariat are leading this project. United Nations has declared 2017 as the International Year of Sustainable Tourism for Development.</p>
<p>WG08 Yacht Harbours</p>		<p>The WG 8 Yacht Harbours is working on 3 projects: on the one hand, the development of Part 2: Minimum requirements for intermediate service level harbours and Part 3: Minimum requirements for high service level harbours and on the other hand, the revision of Part 1 to become a basic service level harbours standard. Part 2 and 3 will be launched for DIS ballot from 17 February until 18 May 2016. Comments received during this consultation period will be discussed in Kuala Lumpur.</p>
<p>WG11 Bareboat Charters</p>		<p>ISO/AWI 20410 Bare boat charter services is being developed by WG 11 led by UK.</p>

<p>WG12 International Volunteer Tourism</p>		<p>The group met in Palma de Mallorca in October 2015 and agreed to meet again in London on 4-5 February 2016. The group is making good progress and the project will be soon ready for CD (Committee Draft Stage). Experts on Charter services from all P members of TC 228 are strongly encouraged to participate actively in this project.</p> <p>ISO/AWI 20496 International Volunteer Tourism was first discussed in Pretoria. A change in the convenorship has delayed progress of the project. Under the renewed leadership of Mrs Angela Benson (UK), the working group will meet again in Kuala Lumpur and will continue to develop the draft. Again, all relevant stakeholders are invited to participate: tour operators, brokers, charities, NGOs, associations, governments and individuals.</p>
---	--	---

29.3 Relevant links

ISO TC 228 Newsletter

http://isotc.iso.org/livelink/livelink/fetch/-8927644/8927662/8927671/16487621/ISOTC_228_newsletter_issue_8.pdf?nodeid=17518694&vernum=-2

ISO TC 228 Public information

<http://isotc.iso.org/livelink/livelink?func=ll&objId=8927644&objAction=browse&viewType=1>

29.4. Information of meetings and consumer participation

Committee	Date of last meeting	Date of next meeting	WG/ Standard(s)	Consumer representative(s) in the key area
TC228	2015/05	2016/05	WG1 Diving Services WG2 Health Tourism WG7 Adventure Tourism WG8 Yacht Harbours WG11 Bare Boat Charters WG12 International Volunteer Tourism	Keith Lewis, Susan Woodhouse (BSI)

29.5. Key person

For further information, please contact: Keith Lewis, kl55bolton@gmail.com at the British Standards Institution.

30. Unit pricing

30.1. Summary

Following COPOLCO's May 2014 resolution for a New Work Item (NWI) on unit pricing, the ISO TMB established ISO/PC 294, *Guidance on unit pricing*, in March 2015. At COPOLCO May 2015 unit pricing was supported as a key area.

Unit Pricing, also known as comparative pricing, is where the price of a commodity is accompanied by a price referenced to a standard unit of measurement. For example a 2 litre carton of orange juice offered at \$7.00 would show a unit price of \$3.50 per litre.

The purpose of the standard is to assist consumers in deciding which item is the best value for money. An international standard could be used by many countries where pre-packaged goods are sold.

In countries that do not have unit pricing, economic risk to consumers is high because of their inability to determine which item is best value for money. In countries that have unit pricing the standard could also benefit by retailers voluntarily adopting parts of the standard to improve the quality of unit pricing. The unit pricing standard would provide principles and guidance in designing, developing and implementing an effective and measurable regime for small to large retailers by establishing best practice for informing consumers of the unit price of goods.

The key consumer objective is to develop a practical guidance standard that assists retailers and regulators to use best practice for displaying and disclosing the unit price of goods.

30.2. Standards work

Committee	Working draft or standard	Progress or change during reporting year Any action to be taken
ISO/PC 294 Guidance on unit pricing	ISO NP 21041 Guidance on unit pricing	Established WG, agreed scope and developed Standard framework

30.3 Relevant links

A video prepared by Malaysia on unit pricing:

<https://drive.google.com/file/d/0B5slUNuDSShzODk4dXpPQTNwc3c/view?usp=sharing>

Steven Cooke ISO/PC Project Manager Steven.Cooke@standards.org.au

30.4. Information of meetings and consumer participation

Committee	Date of last meeting	Date of next meeting	WG/ Standard(s)	Consumer representative(s) in the key area
ISO/PC 294 Guidance on unit pricing	2015/11	2016/04/19	WG and Plenary	Ian Jarratt CI

30.5. Key person

For further information, please contact: John Furbank, johnfurbank@internode.on.net at Standards Australia.



ISO/COPOLCO/WG 2
Key areas for consumers

Email of secretary: mmu@standard.no
Convenorship: JISC (Japan)

Member list COPOLCO WG Key areas for consumers 2016-05-10

Document type: Other committee document

Date of document: 2016-05-11

Expected action: COMM

Action due date: 2016-06-15

Background:

Committee URL: <http://isotc.iso.org/livelink/livelink/open/copolcowg2>

Member-list per 2016-05-10

Member Body	Country	Name	Email
ISO/COPOLCO		Nakakuki, Takashi	nakakuki@jsa.or.jp
ISO/COPOLCO		Murvold, Merete	mmu@standard.no
AFNOR	France	Coly-Dufourt, Ludivine	ludivine.coly@leolagrance.org
AFNOR	France	Reuss, Rémi	remi.reuss@afnor.org
ANSI	United States	Cornish, Steven P.	scornish@ansi.org
ANSI	United States	Miller, Michaela	mmiller@ansi.org
BIS	India	Bhatla, Sneha	ddgt3@bis.org.in
BIS	India	Bhatnagar, P.	spcad@bis.org.in
BIS	India	Khanna, Sri Ram	sriramkhanna@yahoo.co.in
BIS	India	Khanna, Sri Ram	sriramkhanna@gmail.com
BSI	United Kingdom	Heemskerk, Christine	cheemske@gmail.com
BSI	United Kingdom	Homer, Sadie	shomer@consint.org
BSI	United Kingdom	Lewis, Keith	kl55bolton@gmail.com
BSI	United Kingdom	Metham, Sue	sue.metham@bsigroup.com
BSI	United Kingdom	Warne, Caroline	caroline.warne@gmail.com
DIN	Germany	Both, Karin	karin.both@din.de
DS	Denmark	Agger, Maibritt	mag@ds.dk
DSM	Malaysia	Hashim, Khatijah	khatijah_hashim@sirim.my
INN	Chile	López, Marly	marly.lopez@inn.cl
ISO	-	Jang, Hyuk Jo	cssd@kats.go.kr
JISC	Japan	Matsumoto, Tsuneo	tsuneo.matsumoto@nifty.com
KATS	Korea, Republic of	Kim, Jai Ok	jokim@consumerskorea.org
NBN	Belgium	Russell, Stephen	stephen.russell@anec.eu
NEN	Netherlands	Ferro, Imola	imola.ferro@nen.nl
NEN	Netherlands	Hoenkamp, Robin	robin.hoenkamp@nen.nl
SA	Australia	Scotland, Alison	Alison.Scotland@standards.org.au
SAC	China	LIU, Chengyang	liucy@sac.gov.cn
SCC	Canada	Dulmage, Graham Rae	rdulmage@outlook.com

Member Body	Country	Name	Email
SCC	Canada	Ersoy, Suzanna	isosd@scs.ca
SCC	Canada	Geralde, Doug	doug.geralde@csagroup.org
SCC	Canada	Glowacki, Peter	peter.glowacki@csagroup.org
SCC	Canada	Islic, Nicki	nicki.islic@csa.ca
SCC	Canada	McCormick, Norma	normachw@mymts.net
SCC	Canada	Nielsen, Elizabeth	ebn1944@gmail.com
SCC	Canada	Schuessler, Mark	mark.schuessler@tpsgc-pwgsc.gc.ca
SCC	Canada	Sopeju, Emmanuel A	esopeju@rogers.com
SCC	Canada	Webb, Kernaghan	kernaghan.webb@ryerson.ca
SNV	Switzerland	Duncombe, Robert	rodu08@gmail.com
SPRING SG	Singapore	Lee, Koon Chi	lee_koon_chi@spring.gov.sg
UNI	Italy	Compagnoni, Antonio	acomagnoni@database.it
UNI	Italy	Mocchio, Elena	elena.mocchio@uni.com
UNI	Italy	Travaini, Paola	paola.travaini@uni.com



International Organization for Standardization
Organisation internationale de normalisation
Международная организация по стандартизации

AGENDA ITEM 12 CONSUMER PROTECTION IN THE GLOBAL MARKETPLACE WORKING GROUP



AGENDA ITEM 12 REPORT FROM THE WORKING GROUP ON CONSUMER PROTECTION IN THE GLOBAL MARKETPLACE

COPOLCO ACTION: members are invited to comment/approve the proposals and draft resolutions in this report.

New members

The following Norwegian expert has joined the COPOLCO Consumer protection in the global marketplace working group (WGGM):

Mr. Dag Slette-meas
Consumption Research Norway
Oslo and Akershus University College of Applied Sciences
PO box 4 St. Olavs plass, NO-0130 OSLO, Norway
Phone: +47 92 66 36 14
email: Dag.Slette-meas@sifo.hioa.no

He is a researcher in the consumer area and is currently working on collaborative economy issues.

New initiatives

Privacy

At its plenary in May 2015 COPOLCO decided to request the WGGM to undertake a gap analysis of existing standards within ISO, IEC and ISO/IEC JTC1, the ITU and UN/ECE on privacy and protection of personal data in order to identify areas needing further work in consumer protection, for the consideration of the COPOLCO Chair's Group at its meeting in November 2015.

The WG requested Mr Peter Eisenegger, a presenter at the 2015 COPOLCO workshop, on the topic of privacy from a consumer viewpoint, to undertake this task.

Mr Eisenegger's expert view, with which the WG Chair agrees, was that given the scale and scope of the privacy challenges, further gap analysis work by COPOLCO alone would take too long and it would be difficult on a voluntary basis to find the necessary expertise across all the ICT areas involved. It was agreed that a more strategic approach could get a better result.

Because it was not realistic to make an exhaustive inventory, i.e. a classic gap analysis, Mr. Eisenegger developed an overall strategic identification of the issues and observations about the extent (or lack) of what standards are currently covering is where it could be useful. The COPOLCO Chair's Group commented on a first draft of the first "gap analysis" which was a good start, and invited some volunteers to assist and comment on its further development of it from the consumer perspective.

As a key spin off from this gap analysis work Mr Eisenegger produced a list of consumer privacy needs and identified those needs that are relevant to a number of categories, specifically: consumer digitally connected devices as part of the Internet of Things (which includes smart phones, home appliances, wearables, cars and more), Smart Cities, Social Media and Big Data.

The Chair of the WGGM, the COPOLCO Secretariat and Pete Eisenegger had a WebEx link-up on 20 February 2016 to discuss the way forward on the Privacy matter given Mr Eisenegger's time constraints. The following was the agreed outcome of the discussion.

1. **Contact with COPOLCO:** Mr Eisenegger will be the main contact point on privacy for COPOLCO, interacting primarily with the COPOLCO WGGM.
2. **Privacy group and networking:** Mr Eisenegger volunteered to provide "thought leadership". He would prefer to engage an informal group of volunteers composed of consumer representatives on JTC1 identified from the Global Directory, in a forum modelled after ANEC's working methods, working mostly by e-mail. The COPOLCO Secretary and Mr Eisenegger are working together to set up a suitable group for exchange of ideas and information among consumer representatives potentially interested in privacy issues (e.g. experts participating in JTC1 working groups who are identified in the Global Directory as consumer stakeholders, and potentially others). When formed, Mr Eisenegger will approach the GD experts as the pool for the network. Mr Eisenegger will share his materials on the Internet of Things, including the slide set from the May 2015 COPOLCO workshop, with interested consumer representatives.

Mr Eisenegger proposed that as a priority COPOLCO should coordinate ICT consumer reps on the ISO data base

3. **Representation:** in his ICT Consumer Coordinator role and member of BSI ITC 1 mirroring JTC1, , Mr Eisenegger supported the COPOLCO resolution for improved consumer representation with respect to ICT standards and has also worked with the COPOLCO Secretary and Chair of the WGGM towards this goal. BSI ICT 1 made him a UK delegate to the March meeting of the JTC 1 Joint Advisory Group (JAG). For the time being he is working towards becoming a standing member of JTC 1 JAG group as in order to provide a consumer viewpoint on issues in JTC1 and with a particular focus on the data privacy space: in particular:
 - a. IoT design good practices for digitally connected devices
 - b. Traceability of data transfer and trading standards –
 - c. Personal data processing privacy and governance - privacy good practice.

Mr Eisenegger attended the JTC1 Joint Advisory Group meeting on 15 March and brought up the issue of ongoing consumer representation. Certain concepts he introduced at that meeting, notably the cross-cutting nature of good digital practice standards, e.g. on accessibility, privacy, and vulnerability, were not widely understood by the group. The COPOLCO Secretary and Technical Group Manager will continue to investigate ways to facilitate Mr. Eisenegger's positive engagement with the JTC1 JAG. He will also prepare an issues paper for advance consideration at the next meeting (see below).

Mr Eisenegger will **develop an overall short paper for JCT 1 JAG** on consumer representation by April to mid-May. This would be a scene setter as a key backdrop to the Privacy by Design (PbD) NWIP and would address the issue of why we have selected this particular standards area of "by design" to put forward as perhaps the key consumer priority.

4. **Work with Consumers International on privacy:** Mr Eisenegger is discussing ideas on how to familiarize consumer representatives with privacy concepts through on-line and face-to-face courses. This activity is entirely self-generated and voluntary. The 3 parties involved have heavy workloads, both voluntary and commissioned. While there were hopes originally that that this mapping out these ideas could happen within 2-3 months, with Sadie Homer and Julie Hunter the current situation is significantly longer term and may slip further. Sponsorship for this work would change that situation.

5. **Privacy by design:** The WGGM Chair and Mr Eisenegger agreed to work together on a new activity template to build support within COPOLCO launching a New Work Item Proposal on privacy by design standards. The aim is to reduce risks, and generic standards do not currently go far enough. Work on this will begin Mid May and needs to understand and assimilate any of the relevant work within JTC1 produced recently, for example on Privacy Engineering and IoT use cases.
6. **Key person:** Mr Eisenegger confirmed his willingness to be COPOLCO's key person on privacy, but limit this activity to a report of activity to go into the annual Consumers and standards update report and answer questions from experts on privacy issues.
7. **Gap analysis:** The WGGM Chair and the COPOLCO secretary have finalized the "gap analysis" report with input from volunteers in the Chair's Group and with the final OK from Mr Eisenegger (See the annex). Alongside the privacy guides Mr. Eisenegger mentioned at the 2015 COPOLCO workshop in May 2015, this will be a good resource and briefing paper for COPOLCO and privacy network experts.

Action at Fringe meeting: decide on action plan on Privacy for the next 12 months.

Collaborative Economy

One of the presentations at the 2015 workshop in Geneva, by Professor Kernaghan Webb, was on the collaborative economy. Professor Webb pointed out that it is an emergent phenomenon and that regulators have left a consumer protection void at present. What is needed is probably a template, possibly a gap analysis, and road map for future.

This is an economic model to contend with in the future. Resolution 8/2015 called for the "need to adapt business and standardization methods to meet the challenges posed by the rise of the collaborative economy and innovative business models." The same consumer needs for safety, fitness for purpose and product information apply in the online environment but with possibly less punitive sanctions available in case of infringement. Regulation is struggling to keep up.

Consumers are looking for what they want, when they want it, regardless of any risks. The collaborative economy is an underground and sociological phenomenon needing broad discussion and understanding rather than silver bullet solutions.

The CAG agreed that a template should be developed on this topic. The WGGM Chair indicated that he together with Jay Jackson would develop the template and invited any other interested party to contribute. ANSI and Standards Norway submitted comments on the template and a revised activity template has been prepared for comments/approval at the fringe meeting and plenary in June 2016 (see Annex 2).

Action at Fringe meeting: Make a decision based on the revised template.

Consumer vulnerability

Comments raised at the COPOLCO workshop in 2012 indicated that the Banking Ombudsman in Canada had identified vulnerable consumers as the primary source of complaints to his office, with the majority of complaints coming from *older adults, recent immigrants and those consumers with mental health problems*.

Similar disadvantaged groups exist in other countries.

There is no perfect consumer protection system but here was an example of an under-served section of society in a country with an allegedly good consumer protection system.

The British standard BS18477 *Inclusive Services* has been out for more than 5 years so has a track record and feedback on how it's being used and could be improved. An assessment of three consumer organizations that interfaced with consumers, including those in disadvantaged circumstances, had been released on BS 18477.

BS 18477 was reviewed early in 2015, and BSI considered revision for the UK market only at first, but sought feedback on applicability as a possible International Standard. After inconclusive first consultations, the COPOLCO Secretariat launched a formal Committee Internal Ballot to gauge members' support for this work and also to assess members' interest in taking part in future work.

The CIB concluded on 21 April. . 52 votes were cast.

In response to the question "Is the "vulnerable consumer" an important issue in your country?" The answers were 36 Yes; 0 No; 0 undecided; 16 abstain.

In response to the question "Should the Consumer protection in the global marketplace working group develop a new activity template on the "vulnerable consumer"?" The answers were 33 Yes; 1 No; 2 undecided; 16 abstain.

Action at Fringe meeting: To make a decision on the next step for this initiative.

Financial literacy for youth

The Child & Youth Finance International Association had contacted Dutch Standards (NEN) for assistance for the development of a standard for child and youth banking products at the international level. The COPOLCO plenary did not particularly support the proposal particularly as much work on the matters proposed already existed in developed countries in this area. The Plenary did, however, support exploring development of a template on financial literacy for youth.

COPOLCO then approved the new activity template, referenced as Annex 2 to COPOLCO 18/2015, at the 2015 COPOLCO meeting.

The CIB concluded on 21 April. 53 votes were cast.

In response to the question "Does your country support this template for submission as a New Work Item Proposal?" The answers were 28 Yes; 4 No; 1 Undecided; 20 abstentions

In response to the question "If the NWIP is approved, is your NSB likely to nominate an expert?" The answers were 9 Yes; 16 No; 13 Undecided; 15 abstentions

In response to the question "If the NWIP is approved, would your NSB consider providing the secretariat?" The answers were 3 yes (Malawi (MBS), Peru (INACAL), United Kingdom (BSI); 24 No, 11 Undecided, 15 abstentions.

Action at Fringe meeting: To make a decision on the next step on this initiative.

Communicating with consumers

This initiative grew out of a COPOLCO workshop held in Milan in May 2014. There had been strong support shown for a standard on the topic of communicating with consumers in the Milan Workshop particularly from 2 major presenters, Amanda Long and Professor Jonathan Freeman. Amanda Long of CI reported the collaborative economy was an emerging issue and how to get information to consumers in this area was an important issue, as was how information is to be trusted.

In terms of drafting a standard, as opposed to revising a Guide, more interested parties need to get involved. Standards, unlike Guides, are the “gold standard” for business and by way of example ISO 10002 on complaints handling had a higher uptake because it is a standard.

A Task Group was set up at the 2014 plenary to consider the feasibility of a standard on business-to-consumer communication. A paper was prepared by the TG which was presented to the COPOLCO Chair’s Group, which subsequently agreed with the TGs recommendation to prepare an activity template for COPOLCO on this subject. COPOLCO approved this template, referenced as Annex 1 to COPOLCO 18/2015, at the 2015 Plenary.

In the meantime, excellent work has been going on to revise ISO/IEC Guide 14, but there is also strong support for a standard on the matter. At its meeting in 2015, the CAG also agreed that as soon as Guide 14 has been completed then a proposal for its development as an International Standard should be submitted to the TMB.

The Committee Draft of ISO/IEC was circulated for a vote to COPOLCO members and IEC National Committee members, with a question on whether members agree to the circulation of the draft as a Draft Guide. Voting will close on 14 May 2016 so the results were not yet available at this writing, but early indications show strong support. Final results will be reported at the Plenary

Action at Fringe meeting: Make a decision based on outcome of vote.

Counterfeiting

The COPOLCO workshop in Fiji in 2012 drew attention to this issue. It was during this period that the first anti-counterfeiting standards were released and helped identify products with holograms.

The COPOLCO Chair has written to the Chair of the International Consumer Protection Enforcement Network, to generate interest in collaborating on this issue. Recently, the WGGM Chair has liaised with the current ICPEN Chair on market surveillance issues.

An education campaign is planned by ISO/CS – a kit to members to help run national campaign focused by theme and placed on social media. So far, progress has been slow due to lack of resources, but is planned to re-start in the course of 2016.

In the meantime, anti-counterfeiting will be featured in an article within the ISOfocus issue dedicated to “Trust” (look out for the September-October issue).

ISO CS Communications have decided to use a multi-media approach involving:

- *Drip campaign on ISO social media*; centrally orchestrated, highlighting foremost burning issues of greatest consumer detriment
- *Consumer education kit* to distribute to consumer-friendly ISO members to translate/use to equip consumers to act nationally with international support, containing;
 - A checklist for running a national campaign.
 - A small brochure with key facts and images
 - One or several posters focused by theme ready to use and place on local social media if available.

The goal is to highlight what ISO is doing to protect the consumer and to select 4 major areas:

- Pharmaceuticals
- Electronic goods
- Food fraud
- Children's toys

The plan is to launch a social media campaign and leave the 'consumer education kit' concept until later.

Wearable Computers

At its meeting in November 2015, the Chair's Group agreed to identify consumer issues in Wearable Smart Devices in a letter to the IEC SG, and include concerns with privacy and related issues along with a request to comment on the scope of a planned future strategy document that IEC plans to produce on wearables. The CG also agreed to send a copy of the letter to ACOS (the IEC Advisory Committee on Safety).

Jack Sheldon, Chair of the Standardization Management Board, made a presentation to the WGGM on Wearable Smart Devices, and clarified that the Strategic Task Group would only finish its recommendations for October 2016. So it was still premature to propose anything specifically on this, whether a letter to the IEC or a template. The WGGM decided to keep a watching brief on Wearable Smart Devices until a proposal comes out in 2016 and to incorporate WSD into the privacy item.

Update on standards under development

Financial services:

The Working Group, Consumer Protection in the Global Marketplace, has been working with Consumers International and had developed a new work item proposal covering financial services for consumers, focusing on:

- consumer information design and disclosure on financial services,
- consumer protection issues in mobile banking,
- remittances and wire transfers to foreign countries.

which took into account initiatives within ISO TC 68 and other organizations, such as the OECD and the World Bank.

At COPOLCO CAG in October 2012 it was agreed to focus on:

- **mobile banking** - through involvement with TC 68/SC7/WG10
- **remittances**-CI to submit a new NWIP at some later stage

Mobile Banking

COPOLCO members identified mobile banking and payments as one of several critical priority areas for consumers in financial services, both at its 2010 workshop and later at the 2011 and 2012 COPOLCO plenary meetings.

ISO/TC 68/SC 7/WG 10, Mobile banking/payments expanded the scope of working draft ISO 12812, Mobile financial services, and issued a call to the membership of ISO TC 68/SC 7 to nominate experts to participate in WG 10. In particular, the standard has five parts, dealing with

mobile payments-to-person, mobile payments-to-business, financial app management, security/data protection and general mobile banking operations.

The CAG agreed that a notification be sent to all COPOLCO members encouraging their NSBs to cast a positive vote.

Regarding the project 12812, Mobile financial services, the next steps are:

- a DIS ballot on ISO 12812-1 General framework (opening date on 2016-05-17, and closing date on 2016-07-13);

- 4 ballots for TS 12812-2 to -5 (opening date on 2016-05-17, and closing date on 2016-07-13).

Remittances

CI's Financial Services work has identified remittances as an important area for consumers. It has noted, for example in the negotiations around the UN Guidelines for consumer protection, that the G20/OECD principles do not deal with the issue and therefore that the UNGCP should so refer.

A 2012 CI report on remittances identified issues of transparency and competition as key areas that need addressing.

The OECD's work on mobile payments excludes cash transfers without purchase.

CI's paper states that standards could contribute to greater transparency & implementable processes of internationally-accepted best practices in this area and that the Bank of International Settlements/Committee on Payments and Settlements systems would be a useful start to work on any ISO standard in this area.

CI believe that while the work of ISO/TC 68 SC7WG10 preparing ISO 12812-Core banking-Mobile Financial Services is restricted to transfers by mobile phone, some remittances issues fall naturally within the scope of this standard.

When this standard is further developed, it will be possible to identify outstanding areas of consumer concern relating to all forms of remittances. A proposal for a standard to cover these remaining issues could then be developed, in much the same way that the Energy Services standard will use/cross reference the Network Billing standard.

Energy services

Robin Simpson of CI has re-cast the standard on water services, ISO 24510, in energy terms. Four major changes have been made to make the core contents the standard applicable to energy services and increase usability. Some sections have been combined and simplified.

ISO 14452, *Network services billing – Requirements* has been extensively cross-referenced. NSB provisions lobbied for the inclusion of relevant guidance on vulnerable consumers which were completely absent from ISO 24510.

The TMB decided to assign the work to ISO/TC 242, *Energy Management WG 5*, under Korean leadership. The item is now registered as ISO 50007, *Assessment and improvement of energy services to users*. Malaysia is part of the leadership team.

CI is actively participating in this standard's development.

The CAG agreed that a notification be sent to COPOLCO members to support the DIS.

The DIS is now closed, with 93% approval (25 Yes. 2 No).

The next meeting of the Working Group will take place in Stockholm during the week of 13 June to discuss the comments, including from CI.

Contact centres

CDs of the following two standards were circulated to PC members in June and July 2015 respectively for approval to be circulated as DIS.

- ISO 18295-1 *Customer Contact Centres - Part 1: Requirements for customer contact centres*
- ISO 18295-2 *Customer Contact Centres - Part 2: Requirements for organizations employing the services of customer contact centres*

In both cases the result of voting was approval to circulate as DIS, but with comments that were originally intended to be resolved at a PC meeting scheduled for September 2015 in South Africa. That meeting did not materialize owing to financial constraints within SABS, and was subsequently held from 1-5 February 2016 in Austria, where the text of the DIS was agreed, subject to editing. The text were submitted to the ISO Central Secretariat on 2 and 7 March 2016, and being processed concurrently, with a scheduled DIS issue date of 12 May. The next (hopefully final) PC meeting has been confirmed for 3-7 October 2016 in South Africa; final publication of both parts is expected in January 2017.

Unit pricing

The second meeting of ISO/PC 294 was held in April 2016 in Singapore. The meeting was attended by Participating members Singapore, Malaysia, Japan, Canada and Australia. CI also attended as a Liaison Member.

ISO/PC 294 continues to evolve its thinking in relation to the project. The meeting further developed the working draft of the international standard and took into account academic research into consumer education.

The meeting approved the modification to the Scope of ISO 21041 *Guidance on unit pricing*, to include education principles for consumers, industry and government including principles and best practice guidelines for unit pricing displayed by written, printed or electronic means.

The Standard is intended to improve the accuracy and usability of unit pricing for consumers, by retailers (and others in the supply chain), and regulators by-establishing best practice for displaying and disclosing the unit price of products including what unit prices are and how they can be used. This includes:

- defining unit pricing systems and types of labels and promotions to which it may apply;
- assisting retailers (and others in the supply chain) and regulators to improve their current unit pricing systems; and
- enhancing transparency of price information to consumers.

This Standard also includes:

- Where and how unit prices should be displayed;
- The quantities used to express unit price including; weight, length, volume, count, area, and other forms of measure;
- The principles of prominence and legibility of unit price presentation;
- Communication and implementation of unit pricing as per the guidance provided in the international Standard by the key stakeholders.

The focus of this international Standard is applicable to pre-packed consumer products and consumer products sold from bulk where the price is displayed, including:

- At the point of sale, including In store and online; and
- other communications about the product, including advertising by any means.

Although the Committee is working well to achieve expected outcomes it would welcome additional participating members to ensure that the Committee is confident that it is including a wide as possible global perspective on unit pricing as possible.

Consumer Product Warranties

The member body ballot on the NWIP Consumer warranties and guarantees closed around 18 January 2016 and it met the criteria for acceptance with 22 approvals, 4 disapprovals and 9 abstentions. 12 members expressed an interest to participate actively. Countries that expressed an interest to participate included, Bangladesh, Bulgaria, China, Colombia, Czech Republic, Egypt, Italy, Korea, Malaysia, Mexico, Singapore and South Africa.

The designation for the committee to draft the standard is ISO TC 303 - *Guidelines on Consumer Warranties and Guarantees*. The Chair is Dr. Rahmah Ismail (Mrs) and Secretary: Ms. Saral James.

The Scope is the standard is intended for use by producers or sellers of goods and services to offer best practices and requirements for effective warranties when these are provided with goods and services.

The first meeting of the committee is scheduled for February 2017 and will possibly address among others:

1. Agreement on Scope and framework for the standard
2. Timeline to complete work
3. Address comments from members who voted and responded to the ballot
4. Promote increased participation from developing country members and respective communication plan

Proposed resolutions for the COPOLCO plenary

Resolution x/2016

Global marketplace working group (1) - privacy

COPOLCO

approves the report appearing at COPOLCO N /2016 and the gap analysis at Annex 1,
invites the Global marketplace working group to pursue actions on privacy issues as mentioned in the report and, taking into account working group discussions, and comments made at the Plenary.

Resolution x/2016

Global marketplace working group (2) – collaborative economy

COPOLCO

approves the activity template on the collaborative economy appearing at Annex 2 to this report,
invites the Global marketplace working group to develop a New Work Item Proposal for the collaborative economy, taking into account working group discussions, and comments made at the Plenary.

Resolution x/2016

Global marketplace working group (3) – vulnerable consumers

COPOLCO

notes the result of the consultation on vulnerable consumers (N197) appearing at Annex 3 to this report,
invites the Global marketplace working group to develop a New Work Item Proposal on vulnerable consumers, taking into account working group discussions, and comments made at the Plenary.

Resolution x/2016

Global marketplace working group (4) – financial literacy for youth

COPOLCO

notes the result of the consultation on financial literacy for youth (N196) appearing at Annex 4 to this report,
invites the Global marketplace working group to develop a new activity template on financial literacy for youth, taking into account working group discussions, and comments made at the Plenary.

Resolution x/2016

Global marketplace working group (5) – Revision of ISO/IEC Guide 14 into an International Standard

COPOLCO

notes the positive results of the Committee Draft consultation on ISO/IEC Guide 14, *Purchase information on goods and services intended for consumers*

thanks ISO/COPOLCO WG 15 for its revision work on this Guide,

requests the Global marketplace working group to develop a proposal for the consideration of the TMB, requesting the conversion of ISO/IEC Guide 14 into an International Standard.

Annex 1: Gap analysis report on privacy

Annex 2: New activity template on the collaborative economy

Annex 3: CIB results on vulnerable consumers

Annex 4: CIB results on financial literacy for youth



**DRAFT AGENDA – WORKING GROUP ON CONSUMER PROTECTION IN THE
GLOBAL MARKETPLACE FRINGE MEETING**

16 June 2016, 13:00-14:30

Mövenpick Hotel, Geneva, Switzerland

Item		Document	Rapporteur
1.	New Members		
2.	New Initiatives <ul style="list-style-type: none">- Privacy- Collaborative Economy- Consumer Vulnerability- Financial Literacy for Youth- Communicating with consumers- Counterfeiting- Wearable computers- Any new proposals		
3.	Update on standards under development Consumer product warranties Unit Pricing Contact Centres Mobile banking Energy Services		

Identification of current consumer issues in privacy and protection of personal data Report to COPOLCO, based on a preliminary report to the Chair's Group

Peter Eisenegger, COPOLCO Key Person Data Protection and Privacy

1. Introduction

Commissioning this report

In Geneva May 2015 COPOLCO resolved to undertake a privacy needs gap analysis as in the COPOLCO resolution below.

COPOLCO Resolution 8/2015

2015 workshop, The connected consumer in 2020 – empowerment through standards
“decides to request the Consumer protection in the global marketplace working group to undertake a gap analysis of existing standards within ISO, IEC and ISO/IEC JTC1, the ITU and UN/ECE on privacy and protection of personal data in order to identify areas needing further work in consumer protection, for the consideration of the COPOLCO Chair's Group at its next meeting in November 2015,”

At COPOLCO's request Peter Eisenegger, as COPOLCO's key person for data protection and privacy, has under taken a preliminary gap analysis, drawing largely on a study of Smart Cities and JTC 1 SC 27 WG 5, *IT Security Techniques* and produced this report for COPOLCO. The review and its report is a first step in the COPOLCO process of identifying and confirming gaps in current international standards addressing consumer/citizen privacy needs. One challenge met in this report has been how to review, on a voluntary basis, such a large set of technical standards and reports relevant to consumer privacy.

2. The Privacy approach taken in this review:

2.1. Privacy standards – generic or specific?

The starting point for the review is the COPOLCO detailed list of privacy needs, provided in Annex 1. These needs are based on BSI/CPIN and ANEC Privacy Guides for consumer representatives. These guides cover the developed countries' privacy needs and COPOLCO representatives for developing countries are currently examining whether any extra needs and requirements should be added from their perspective.

The approach adopted for this report is that privacy needs are best addressed in a manner that is more like product safety implying that product and service specific standards are required.

Of the privacy initiatives under way, that of the EU's Privacy by Design (PbD) M530 standards development programme is on track to achieve better products and service specific standards by developing good practice for privacy by design for products and services.

For this report, only ISO standards and working documents have been readily available, and time and effort constraints have only allowed a few of those to be reviewed. The author has

already reviewed some documents referenced in the report at an earlier date in order to contribute to UK National Body reviews and formal National Body comments.

2.2. Privacy by Design (PbD)

In overview a PbD approach needs generic standards for the design and design updating process with “use cases” providing the context for which privacy has to be designed in. Figure 1 provides a simplified PbD process flow.

Figure 1 A simplified Privacy by Design process

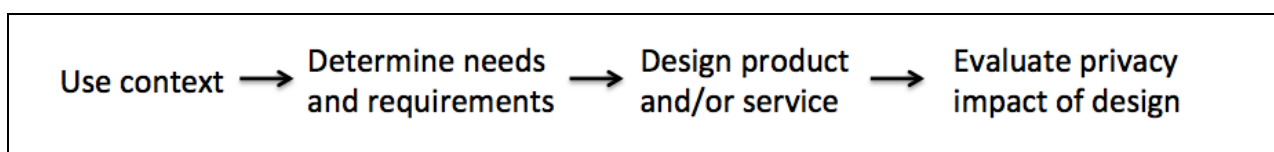

Standards are needed that ensure that the right use context is set for determining which privacy needs and requirements have to be met by the designers. Then once a design is mature enough to be evaluated a privacy impact assessment process is run and from that an impact statement or measurement is determined that leads to a go/no go decision on the design.

However the design and implementation issues run deeper than that, as designs and their real life implementations have to be kept under review and assessed for their privacy impact throughout the product or service lifecycle. A case in point is the CEN TC 225 Liaison report for CEN/CENELEC JWG 8 in which the prior EU state of the art work on RFID privacy impact assessment was reviewed (the report is available upon request).

3. Taking Privacy by Design as an approach to meeting consumer privacy needs.

3.1. Generic standards

The EU’s M530 programme is likely to deliver a great deal that is relevant, however that EU work itself will be founded on ISO/IEC JTC 1 generic standards and so a key part of this review has looked at the privacy needs gaps issues in the JTC 1 domain in as much detail as possible with voluntary effort. However when it comes to product and service use case specifics then JTC 1, while having sub committees pertaining to some sectors, is nonetheless very generic in its standards requirements.

3.2. Context and use standards

While much of JTC 1’s work is generic, it is possible to find this type of context and use approach within ISO/IEC JTC 1. For example, Big Data has a proposal for both use cases and utilizing templates to provide context. At the end of August 2015 the ISO/IEC JCT1/WG9 on Big Data issued a contribution on Big Data Use Cases and Derived Requirements, ISO/IEC JCT1/WG9 N103. This document itself builds on the ISO/IEC Cloud Computing SC38 Standing Document 2 which gives the compendium of Cloud Computing Usage Scenarios and Use cases, as well the associated methodology and guidelines.

This might mean that the wider ISO Technical Committee community have to be involved for product and service specifics. Annex 2 provides an analysis of the coordination and involvement that might be involved for COPOLCO and the Technical ISO Management Board to consider.

Then beyond ISO's own TC's there are even wider issues of liaison and coordination with a significant number of other international standards bodies such as the ITU, ETSI and others.

4. Summary Results of the preliminary gap analysis

The privacy needs of Annex 1, when examined in detail against the specific documents referenced in this report broadly indicated that there are three key areas where current ISO standards development seems to have significant privacy gaps that should be addressed. That said, it is important to recognise and understand that the core standards laid down by JTC 1's committees are of good quality from the consumer perspective and the issue is about building on and enhancing these where 21st Century digital privacy needs are yet to be fulfilled.

The three key strategic gaps that have been identified are illustrated in figure 2, below. They relate to protecting consumer's privacy in the domestic environment and providing privacy control, the issues of anonymity and residual identifiability and the traceability / transparency of data sharing and trading.

Gap A Domestic environment and processing: domestic privacy.

- As consumers are non-experts, domestic equipment (e.g. home, car and personal networks and devices) needs to have security controls and updating processes that are extremely easy to understand and operate.
- With frequent and/or continuous data collection, real time privacy control is needed (24/7 privacy preferences control, including in consumer-targeted software).

Gap B Increased identifiability: analysis of consumer data.

- Large scale data collection means that, even after anonymization, levels of residual identifiability need to be addressed.

Gap C. Increased transparency of data sharing: traceability and transparency

- In order to support data protection law in the world of data sharing and trading, technical standards are needed for traceability and transparency.

Figure 2 Strategic Privacy Gaps

Strategic Privacy Gaps

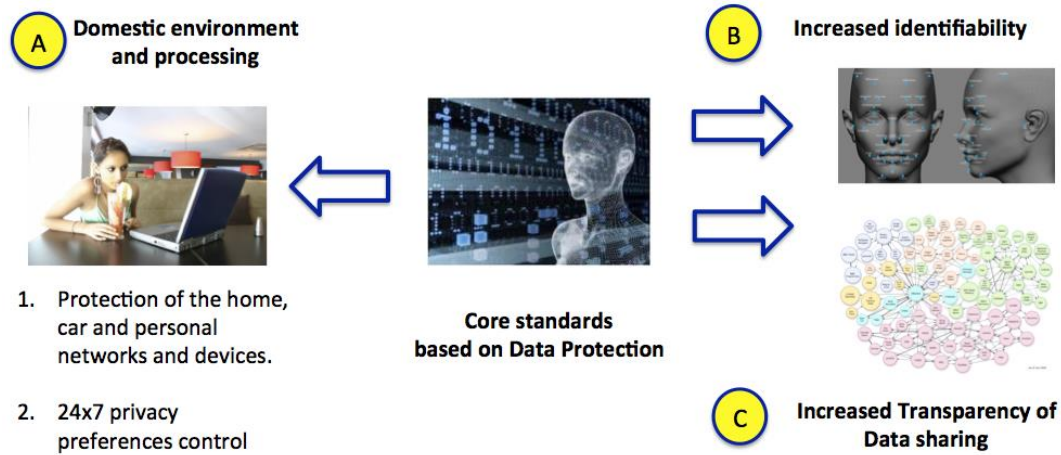

A, B and C are all areas where standards need to be enhanced

5. Review of a key JTC 1 report

In order to address the gap analysis as well as the circumstances allowed, then the recently received JTC 1 report “SG 1 (Smart Cities) Second Phase Report Submitted to the October 2015 meeting in China” was very welcome. This report was used as the basis since Smart Cities¹ are an extremely wide privacy context and as such the topic embraces the great majority of privacy issues that consumers and citizens face.

The SG1 report has 3 aims expressed in its scope and purpose that relate to consumer privacy.

The aims listed are:

- investigate ICT standardization requirements and techniques that contribute to enhancing individual control over personal data while recognizing the benefit to society of the sharing of pertinent personal data;
- investigate ICT standardization requirements and techniques that contribute to enhancing cybersecurity in a smart city;
- explain the value of requirements for standardized risk assessment methodologies that underline the dependencies across organizations and sectors inherent to Smart Cities;

It should be noted this analysis is limited to two areas; smart cities and JTC1 SC 27 WG 5, and that the SG 1 Second Phase report references core ISO/IEC privacy standards that are also commented on in the review of the SG 1 report.

¹ It is worth noting that BSI PAS's 181 and 182 are important sources in the SG1 analysis and Peter Eisenegger as BSI's ICT Consumer Coordinator was on the steering groups for both of these smart cities standards.

5.1. Preliminary Review of Privacy Needs Gaps based on JTC 1 SG 1 Smart Cities Second Phase Report, ISO/IEC JTC 1 N12790

See Annex 1 for a summarized list of consumer digital privacy needs. Topic 1 potentially impacts all of the issues identified in Annex 1. References to relevant sections of Annex 1 are made in each of the other topics.

Topic	Smart Cities phase 2 report sections	Privacy gaps commentary
<p>1. The consumer / citizen perspective is missing</p> <p>‘Privacy in Depth’ model not addressed</p> <p>Gap A (Domestic privacy)</p>	<p>5.1.2 Developing a Reference Framework for a smart city from an ICT perspective</p> <p>The JTC 1 Smart City Study Group considered that an effective contribution that JTC 1 could make to support smart cities would be to develop a Smart City Reference Framework from an ICT Perspective. It further concluded that this would best be done by developing three distinct, but linked, smart city views that relate to the areas of JTC 1 competence:</p> <ul style="list-style-type: none"> • A Smart City Business Process View • A Smart City Knowledge Management View • A Smart City Engineering View <p>Also it should be noted that 7.1.3 The role of JTC1 with respect to ICT Standards for Smart Cities states:</p> <p>“There are four differentiators that separate a city’s use of ICT from that of other organizations²:</p> <p>1. Citizens at the centre. The city largely exists for the benefit of its citizens, who by virtue of living in the city are impacted by many of the ICT and related services the city provides. There may be no practical “opt out” option for citizens and the city must provide a duty of care to all its citizens. In addition, increasingly citizens are driving many initiatives that are making</p>	<p>There is no Consumer / Citizens’ view for Smart Cities</p> <p>The core viewpoint of consumers is embedded in the COPOLCO privacy needs, since the BSI/CPIN & ANEC privacy guides are built round the consumer perspective as expressed by the Privacy in Depth model. Privacy in depth puts the consumer / citizen at the centre of protection and control of his/her data.</p> <p>The different approaches of Privacy in Depth (PID) and Security in Depth (SID) model as used by JTC 1 SC 27 is explained below³.</p> <p>“The RFID PIA standard establishes a ‘privacy in depth’ (PID) model adapted from an ISO 27000 series ‘security in depth’ (SID) model. The difference between the two is that security in depth focuses on the organization and its core processing capabilities and the organization’s ability to control both the technology and the processes, whereas the privacy in depth approach focuses on the consumer digitally connected device that is not under the control of the organization, especially when the application it not interacting with the consumer’s device. And so PID needs at its core the privacy and</p>

² Only one is mentioned here

³ CEN TC 225 liaison report to the CEN/CENEC JWG 8 developing the work program for the EU’s M530 Privacy by Design standards development

	<p>the city work more smartly, by actively providing feedback to service providers in the city and by using the increasing number of applications designed to help them manage their own lives better in the city.”</p> <p><i>Reviewer’s note: The Citizens at the Centre factor is not as strong a differentiator as put forward here. Many commercial services have no practical ‘opt out’ from the consumer’s point of view and commercially much law and regulation confirms that businesses do have a reasonable duty of care whatever goods and services are sold to consumers.</i></p>	<p>security capabilities of the digitally connected device. The two models complement each other with PID dealing better with the protection of individuals using digitally connected devices against a range of threats and SID protection of an organization’s data including the personal data⁴ collected or processed by an organization.”</p>
<p>2. Data Protection and privacy expressed as a “barrier”</p> <p>Gaps B and C (analysis of consumer data, Traceability /transparency of data sharing)</p>	<p>In section 5.3 Smart City Knowledge Management View When examining sharing data the SG have identified the core privacy issues as barriers:</p> <p>“It may also need to reflect barriers to data interoperability.</p> <ul style="list-style-type: none"> • Privacy - Conforming to human rights and data protection requirements when handling data that refers to people. • Security - Protecting data from accidental or malicious destruction, or unauthorized access. • Integrity - Avoiding data corruption as data is handled, copied, processed, and transported. • Quality - Characteristics of data such as completeness, validity, consistency, timeliness, accuracy, precision, and tolerance. It is important to understand the quality of data when considering if it can be reused for a new purpose • Provenance - The traceability of data, from collection, through 	<p>There is a risk that expressing these issues as barriers will lead to them not being properly addressed in standards.</p> <p>The approach taken for COPOLCO for the privacy needs gap analysis is to treat these topics as privacy by design issues for data transfer and sharing. Key privacy needs related to these issues are identified in Annex 1 with high level technical design requirements proposed for data transfer and sharing solutions put forward from the consumer perspective in the associated privacy guides.</p> <p>Ref http://www.anec.eu/attachments/A/NEC-ICT-2015-G-040.pdf</p>

⁴ defined by ISO as personally identifiable information (PII)

	each transformation, analyses and interpretation.”	
<p>3. Consumer sourced data</p> <p>A) The role in ICT systems of social media</p> <p>Gaps A and C (Domestic privacy, Traceability /transparency of data sharing)</p> <p>B) Data capture from sensors</p>	<p>5.4 Smart City Engineering View</p> <p>5.4.1 Objectives and approach</p> <p>The report in Figure 5.3-2 (below this table) provides an initial Smart Cities Solution Concept Diagram of an overview of smart cities organizational layers.</p> <p><i>Reviewer’s note: This picture does not include smart cities’ use of consumer/citizens public and socially shared information and views. Sensor Data collected from consumer’s own devices is included however as ‘crowd sourced’ data.</i></p>	<p>A) In the UK BSI smart city standards work, (as well as other areas like complaints handling by companies and reputational assessment systems), social media and consumer views expressed publicly are becoming vital elements of how organisations of all types interact with their consumer customers and the public in general.</p> <p>This gap regarding the use of social media is addressed in the privacy guide addressing domestic privacy and the privacy of digitally connected devices section 4.</p> <p><i>Ref.</i></p> <p>http://www.anec.eu/attachments/ANEC-ICT-2015-G-064.pdf</p> <p>B) The sensing layer at the bottom of the diagram includes both public monitoring “City sensor webs” and “Crowdsourcing” of data from personal digitally connected devices.</p> <p>The privacy needs associated with such collection of sensing data are also addressed in ANEC-ICT-2015-G-064.</p>
<p>4. Security necessary to protect privacy</p> <p>Gaps A and B</p>	<p>9. ICT standardization requirements for cybersecurity and privacy</p> <p>9.1 Two linked, but distinct areas: These two issues are often considered together, because many of the most high profile failures in handing personal data have resulted from weaknesses in cybersecurity. However, for clarity, these are best dealt with separately. Privacy is first and foremost a matter of developing and following personal data protection policies and designing ICT systems to enable this. The prevention of leakage of private data due to</p>	<p>JTC 1 SC27 plays a pivotal role in generic security and privacy standards and ISO/IEC 27002 <i>Code of practice for information security management</i> is specifically referred to in the report. In practice when it comes to keeping data secure inside an organization’s firewall (be it personal data or any other type of data), there are a great number of very good quality standards available from SC 27.</p>

	<p>failures of cybersecurity is best dealt with as part of the general process of controlling access to sensitive data.</p> <p>9.2.3 ISO/IEC 27002 ISO/IEC 27002 <i>Code of practice for information security management</i> is an important generic standard in this area.</p>	<p>The JTC 1 Smart Cities report highlights ‘the prevention of data leakage as the main risk, which is true, however that means that the key security trend identified in CISCO’s 2014 Annual Security Report has not been addressed. (See section 2.2 of the privacy guide ANEC-ICT-2015-G-064.) The key trend is that consumer equipment and behavior is now integrated into the organization’s ICT systems and the whole security attack surface has increased significantly because of that.</p> <p>The implication of this is that the SC 27 “27000” series of standards should be carefully reviewed to check how well they cope with consumer digitally connected devices (such as mobile phones, gaming consoles, smart televisions etc.) that are beyond the direct usage control of the organization, and how well the security on such devices can be maintained.</p> <p>Also see Topic 8.</p>
<p>5. Overall privacy framework</p> <p>Gaps A and B</p>	<p>9.3 Privacy 9.3.2 ISO/IEC 29100:2011 Privacy framework The privacy framework is intended to help organizations define their privacy safeguarding requirements related to PII within an ICT environment</p>	<p>The key SC 27 standard addresses, in a good quality manner, the needs of organisations in defining their requirements for meeting the data protection principles. However 29100 is not geared to the privacy aspects of domestic purposes processing undertaken by consumers, where consumers effectively have a type of data controller responsibility. Such as quasi data controller role has been referred to by Data Protection regulators like the UK ICO.</p> <p>This domestic processing perspective is difficult to address in 29100 and so the domestic privacy needs identified for COPOLCO in Annex 1 are aimed</p>

		<p>at those privacy control needs relating to the goods and services purchased and or used by consumers.</p> <p>The COPOLCO privacy needs approach to domestic privacy should assist privacy by design initiatives where consumer digitally connected devices are part of the processing solution.</p>
<p>6. Privacy impact assessment</p> <p>Gaps A, B and C</p>	<p>9.3.4 ISO/IEC 1st CD 29134 Privacy impact assessment Guidelines</p> <p>A privacy impact assessment (PIA) is a tool for assessing the potential impacts on privacy of a process, an information system, a programme, another initiative and a software module or a device and, in consultation with stakeholders, for taking actions as necessary in order to treat privacy risk. A PIA is integral to the process for privacy risk treatment. A PIA report may include documentation about measures taken for risk treatment, for example, measures arising from the use of the information security management system (ISMS) in ISO/IEC 27001.</p> <p>A PIA is more than a tool: it is a process that should begin at the earliest possible stages of an initiative, when there are still opportunities to influence the outcome of a project and thereby ensure privacy by design. It is a process that should continue until and even after the project has been deployed.</p> <p>This International Standard gives guidelines for a process on privacy impact assessments and a structure and content of a PIA report.</p>	<p>Privacy impact assessment is fundamental to achieving good quality privacy protecting goods and services for consumers and citizens.</p> <p>This standard has been reviewed and commented during its development by COPOLCO's key person for Data Protection and Privacy. The standard is still 'behind the firewall' oriented and less capable or specific when consumer digital devices are part of the system being evaluated. The following 8 PIA principles for consumer digitally connected devices were put forward for consideration in drafting ISO 29134, the principles being derived from the privacy guide ANEC-ICT-2015-G-008 on privacy impact assessment for consumer digitally connected devices.</p> <ul style="list-style-type: none"> i. Assessing the privacy implications of any remote ability to cause any digital device used by consumers to power up or power down ii. Assessing the privacy implications of eavesdropping radio emissions when a device is powered up and in operation iii. Assessing the privacy implications of the device and network security, and any mismatch of security configuration between device and network

		<p>iv. The default when data types are unknown should be evaluation of the most sensitive of personal information being processed and transmitted in both directions</p> <p>v. The privacy implications of the sensitivity of the data types processed and collected should be evaluated</p> <p>vi. Assessing the privacy implications for the degree of privacy preference control available to the user</p> <p>vii. Assessing the privacy implications of user behaviour and their use of digital devices should be evaluated to identify privacy risks brought about by how the device is used in domestic life</p> <p>viii. Assessing the risk to privacy should be evaluated for personal data lost or stolen from an organization leading to the linking of that data to an individual either through</p> <ul style="list-style-type: none"> - the data itself - linking to the device used by the individual <p>The final version of this standard will need to be carefully reviewed to establish how well it addresses the privacy assessment issues of the consumer's digitally connected device.</p>
<p>7. Privacy and shared data</p> <p>Gap B:</p>	<p>9.3.6 Managing privacy when data sets are shared</p> <p>One privacy issue in a smart city is related to the sharing of data. An organization might want to share an anonymized data set with another agency in the city or to provide it as open data but needs to be sure that measures are in place to address the potential for private information to be inferred from that data set, should it be aggregated with data held elsewhere.</p>	<p>(1) This new work item to address de-identification techniques is an important step that helps address the privacy need for anonymization listed in section 3 of the COPOLCO Privacy Needs List given in Annex 1 however there are two more key needs identifies that are closely associated with this data sharing issue in that section specifically:</p> <ul style="list-style-type: none"> • the need to address re-identification and the issue

	<p>In order to tackle this issue, guidelines on anonymization and pseudonymization are being worked in SC 27 in a recent NWIP on “Privacy enhancing data de-identification techniques” which is currently under CD ballot (N15297).</p>	<p>of what is the acceptable level of residual identifiability for a processing purpose</p> <ul style="list-style-type: none"> • The need to address large scale profiles built up of individuals especially as many data sets are assembled where such profiles become intrusive into an individual’s domestic life. <p>(2) Section 9.3.6 of the Smart Cities report does not address at all the traceability and transparency needs that support Data Protection law and principles. These are identified in section 2 of Annex 1</p>
<p>8. Good quality risk assessment for the domestic environment</p> <p>Gap A</p>	<p>10.3 What is risk assessment</p> <p>....</p> <p>Risk Assessment itself describes the overall process of:</p> <ul style="list-style-type: none"> • risk identification; • risk analysis; and • risk evaluation <p>[ISO Guide 73:2009, definition 3.4.1]</p> <p>Risk identification involves identifying what might happen, or what situations might exist, that might affect the achievement of the objectives of the system or organization. It includes identifying the causes and source of the risk (or hazard in the context of physical harm), events, situations or circumstances which could have a material impact upon objectives and the nature of that impact.</p> <p>It is important that due recognition is given to human and organizational factors when identifying risk. Hence, deviations of human and organizational factors from the expected should be included in the risk identification process as well as “hardware” and “software” events.</p> <p>Risk analysis is about developing an understanding of the risk by determining the consequences and</p>	<p>(1) With consumer equipment being part of many organisation’s digital processing processes in the 21st Century, then how well organisations handle risk assessment and their subsequent decisions dramatically impacts both consumer digital security (and hence privacy) as well as the organisation’s own security.</p> <p>Many of the privacy oriented standards refer to ISO/IEC 27002 whose section 6.2.1 Mobile device policy is the nearest to addressing such domestically owned or used equipment but it is currently too business equipment oriented.</p> <p>The involvement of domestic equipment means that both security and privacy control needs as identified in section 1 of the Privacy Needs list in Annex 1 have to be addressed too, and currently they are not.</p> <p>(2) ICT risk assessment is a deeply technical and complex issue as products have both generic and specific vulnerabilities</p>

	<p>their probabilities for identified risk events. The consequences and their probabilities are then combined to determine a level of risk.</p> <p>Risk evaluation involves comparing estimated levels of risk with risk criteria defined when the context was established, in order to determine the significance of the level and type of risk. It uses the understanding of risk obtained during risk analysis to make decisions about future actions.</p> <p><i>Reviewer's note : for completeness a key extract from ISO/IEC 27002:2013 is included here:</i></p> <p>Section 6.2.1 Mobile Device Policy <u>Control</u> A policy and supporting security measures should be adopted to manage the risks introduced by using mobile devices.</p> <p><u>Implementation guidance</u> When using mobile devices special care should be taken to ensure that business information is not compromised. The mobile device policy should take into account the risks of mobile devices in unprotected environments.</p> <p><i>Reviewer's note: there has very recently been proposed a new work item proposal on Privacy-specific application of ISO/IEC 27001 – Requirements</i></p>	<p>and exploits rise and fall in the market place with a huge amount of malicious innovation to cope with.</p> <p>The reviewer's experience of privacy impact assessment standards for with one of the simplest of ICT technologies suggests strongly that in addition COPOLCO need to check if there are process standards for the significant area of concern that is good practice in the collection, publication and use of product and service vulnerabilities.</p> <p>Further, given that neither many smaller businesses nor consumers have the expertise and resources to undertake such complex risk assessments the role of automation of PIA processes should be carefully examined for possible new standards.</p>
--	--	--

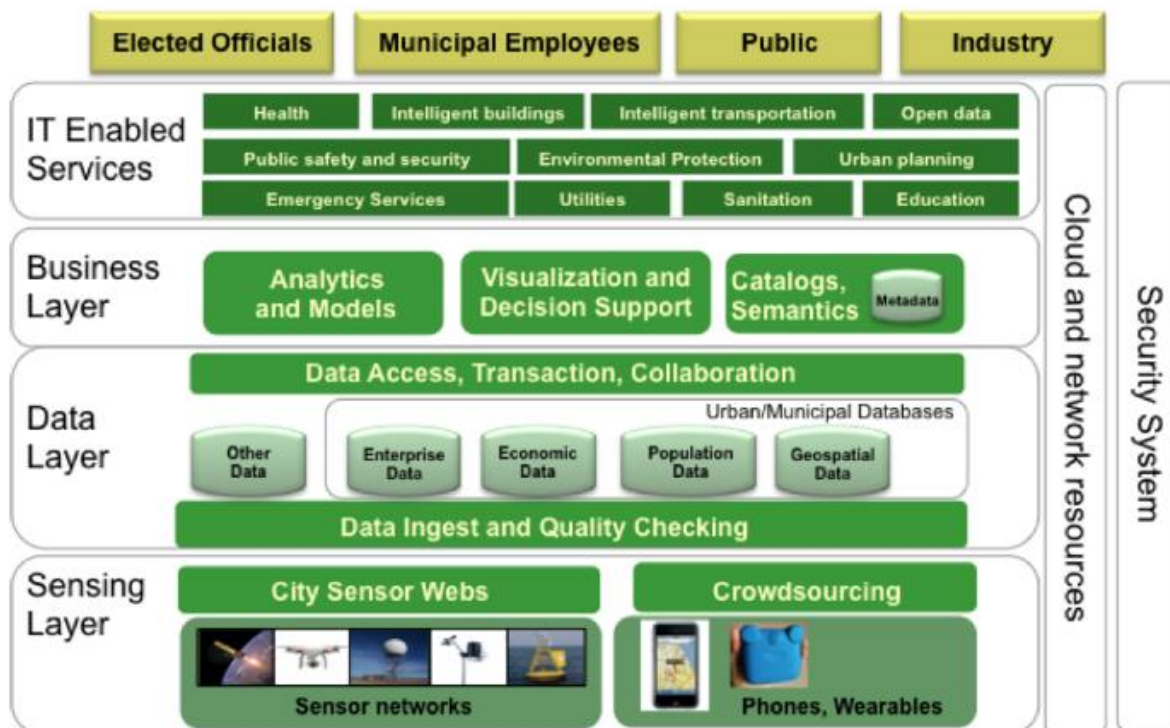

Figure 5-3 Smart Cities Solution Concept Diagram

5.2 Core JTC 1 SC27 Working Group 5 Information technology - Security techniques – Identity management and privacy technologies current projects.

Note: This section should be read in association with the 4th Draft Agenda of the 20th meeting of ISO/IEC JTC 1/SC 27/WG 5 in Jaipur (India) 2015--10--26 to 2015--10--30

After the above identification of apparent privacy gaps at a strategic level, then at least one of the top priority areas would be the standards addressed by the SC 27 Working Group 5 that impact privacy. SC27 WG5 are a primary source of generic international privacy standards.

In order to address a more detailed gap analysis in this core area covering consumer privacy protection (domestic security), privacy control 24x7, identifiability issues and data sharing / transfer transparency and traceability a gap analysis process and resources would be need to be put in place. While the resourcing issue cannot be addressed in this report, a possible methodology has been drafted for COPOLCO's consideration and is available on request. The associated agenda for the SC27 WG5 meeting in October 2015 shows that the group already have many key liaisons in place as well as 17 standards that would need to be examined for more detailed gaps and 4 study periods under way that might also need consumer contributions.

In addition the privacy protection through security needs to be carefully examined across SC27's work, for example a new work item proposal has just been made on Privacy-specific application of ISO/IEC 27001 – Requirements

6. Proposals for next steps

The following are potential steps for COPOLCO listed in the priority order as that seems appropriate to the reviewer.

6.1. Determine how to secure the consumer perspective through consumer representatives in relevant ISO/IEC/ITU work and in national mirror committees and appoint a COPOLCO Key person in relevant JTC 1-work. .

This particularly needs to address

- i. the scarcity of voluntary consumer privacy expertise (hence the need to identify and network effectively among representatives)
- ii. the role of use case standards for specific products and services

6.2. Develop a new activity template on an International Standard for Privacy by Design (PiB). This would start from the ISO 9000 plan, do, check, act cycle as the EU PbD Mandate 530 has. The plan do check act cycle would lead to a simpler, easier to understand process than other documents currently being developed within ISO.

6.3 Address priority privacy gap filling areas to be agreed with ISO based on:

- i. Standards addressing the security of consumer's domestically used digitally connected devices.
- ii. Provision of 24x7 privacy preferences control for consumers via their digitally connected devices (this is also related to i.)
- iii. Standards addressing acceptable levels of identifiability and sensitivity of data sets about individuals
- iv. Data sharing, trading and transfer traceability and transparency standards

6.4. Determine how the wider standards community beyond ISO and JTC 1 could be addressed to identify privacy gaps that lie elsewhere from the consumer perspective as business processes become increasingly digitized.

6.5. Institute two study periods to consider

- i. the role and significance of privacy impact assessment automation systems
- ii. the role and significance to privacy impact assessment of standards for products and service vulnerabilities and exploits information capture on an industry wide and industry shared basis

6.6 Agree and communicate the consumer digital privacy needs as described in Annex 1. e.g. by presenting an adapted form of this report at the next plenary meetings of JTC 1 and JTC 1 SC 27.

6.7 Undertake a gap analysis of consumer protection in wearable smart devices.

6.8 Promote better information about the standards on privacy protection to make a broader use of what already exists.

Annex 1 **Consumer Digital Privacy Needs**

1 General consumer domestic privacy needs

Security of domestically used digital equipment (hardware and software)

- Network and system security
- Consumer digital devices security
- Keeping consumer protection up to date
- Sourcing trustworthy apps and applications
- Loss of digital devices
- Consumer device security over a product lifecycle
- Consumer security information

Consumer domestic personal processing privacy control

- Consumer privacy preferences and control in real time (24x7)
- Consumer privacy control in cloud computing services via 3rd party apps
- Consumer privacy control for the Internet of Things including smart domestic appliances and cars
- Consumer privacy control for remote control of Things
- Consumer privacy control when 3rd party responsible persons need to be involved (e.g. parents and carers)

Consumer control over their data sharing over social media

- Consumer privacy control over the social distribution of their shared data
- Privacy controls with respect to those receiving socially shared personal information
- Privacy controls when an individual is identifiable in someone else's shared data

Privacy and intrusive content

- Consumer privacy controls for intrusive content
- Consumer privacy controls for intrusive (false) equipment control commands

Consumer privacy control over data collection by third parties

- Consumer privacy preferences and control in real time (24x7)
- Service impacts when privacy data collection preferences are changed by the consumer
- Consumer privacy preference changes and service interactions
- Maximum consumer protection by default

Privacy in public places (physical and virtual spaces)

- Personal data analysis that removes anonymity
- Anonymity when personal information is collected via sensors

Personal accountability for online views

- Accountability for statements and views made online:

- Direct to individuals
- About individuals in public virtual domains

2 Consumer privacy needs when personal data is transferred and traded once it has been collected

Personal data traceability and transparency to support data protection law

- General personal data transfer traceability
- Traceability of transferred data for consumer consent
 - Consent to new processing purposes
 - Consent traceability within original data processing consents given
- Traceability of transferred data for the purposes of personal data access and correction requests
- Consumer query - "where did you get my data from?"

Managing personal data transfer traceability Requests

- Validation of 'trace my data' requests

3 Using Consumer Personal Data (data analysis)

Balancing the right to privacy with the public interest

- Governance
- Engaging stakeholders

Anonymity

Re-identification

Profiling: Building up large personal profiles

Data fitness for purpose

Existing customer or client data analytics

Analysis of personal data from open data

Data analytics to identify or target an individual

Data analytics to identify groups of people

Data analytics for systems

4 Consumer Privacy (applicable to some other areas too)

The Right to be Forgotten

Privacy by Default

Privacy by Design

5 Developing Countries Privacy Needs additional to 1, 2, 3 and 4 above

Currently under development within COPOLCO

6 Privacy Impact Analysis for consumer digitally connected devices

Note on key risk areas that consumer digital device Privacy Impact Assessment 's need to address

- Remote control over device power
- Eavesdropping digital radio emissions from devices
- Data transmission to and from the connected device (security)
- User control of data types passed over networks and remote processing of that data
- User personal data sensitivity
- User control over personal privacy preferences
- User behaviours
- User privacy exposure arising from organisational security breaches

7 Privacy information to be provided to consumers (derived from CEN EN 16750)

Public place privacy awareness notification and signage

Consumer product/service information

- Consumer Privacy Information Provision Policies
- Summary of privacy impact assessment
- Privacy risks and mitigation actions
- Privacy control instructions
- Privacy labelling
- Privacy and security of domestic equipment maintenance instructions
- Privacy complaints and queries

Annex 2 ISO Coordination associated with meeting privacy needs

A2.1 Preliminary coordination analysis – With a focus on digitally connected devices and goods and services used by consumers a preliminary survey has been undertaken of JCT1 SC's and SG's, the other ISO Technical Committees (TC's) that deal with consumer products⁵ and other areas like anti-bribery management that may process personal data (also referred to in ISO standards as Personally Identifiable Information – PII).

Figure 2 provides an overview of the coordination landscape that ISO is probably facing when it receives the privacy needs gap analysis request from COPOLCO. Detailed lists of committees are provided in Annexes 2.2 and 2.3.

Figure 2 The ISO Privacy Standards Coordination Landscape – a preliminary view

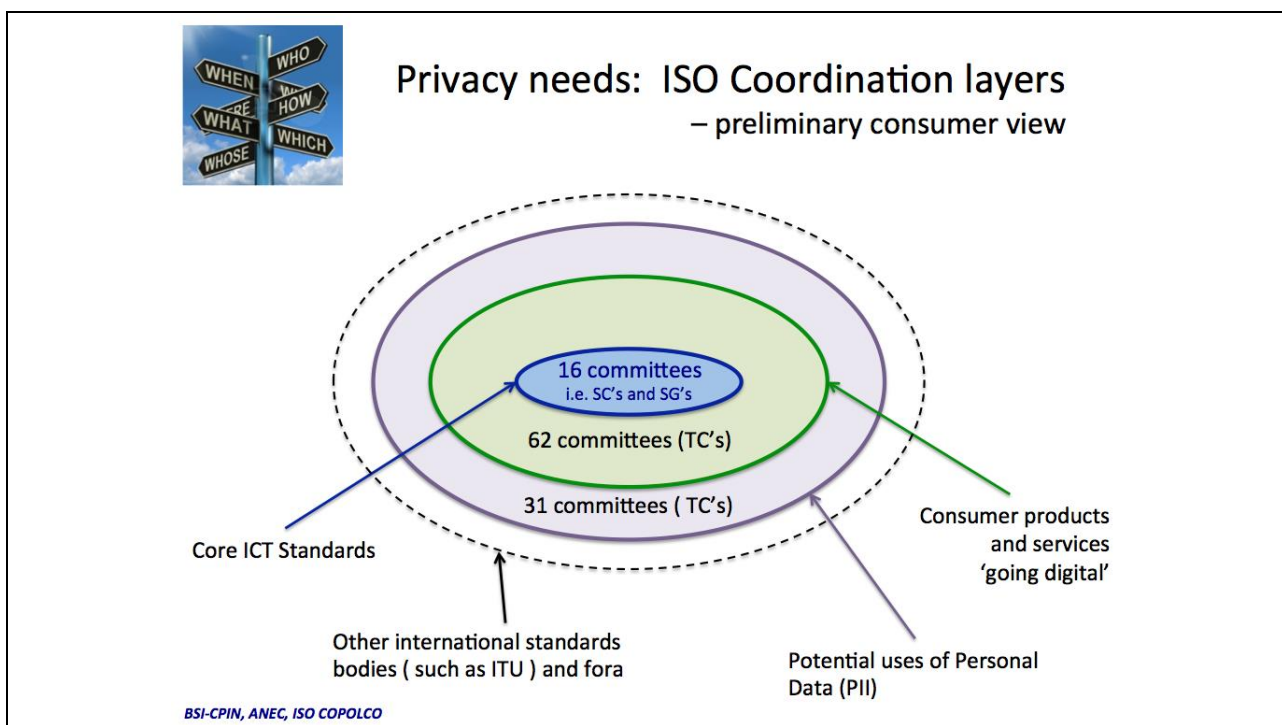

In summary it seems as though up to 16 committees might be involved within JCT1 in order to provide the core standards for privacy to underpin that provided by consumer products. Further there may be over 60 ISO committees involved in setting the right product privacy contexts and over 30 committees involved in setting the right PII processing contexts for privacy by design.

There are other International standards bodies such as the ITU and industry standards fora that also need to be considered and involved.

⁵ Products here is used to embrace both products and services from public, voluntary and private sector providers

A2.2 JTC1 Committees potentially involved in meeting consumer privacy needs

Applicability of consumer privacy needs to SC & SG work

Technical Areas	JTC1 Subcommittees and Working Groups	
Application Technologies	SC 36 - Learning Technology	SC 36 yes
Cultural and Linguistic Adaptability and User Interfaces	SC 02 - Coded Character Sets SC 22/WG 20 – Internationalization SC 35 - User Interfaces	SC 35 yes SC 17 yes
Data Capture and Identification Systems	SC 17 - Cards and Personal Identification SC 31 - Automatic Identification and Data Capture Techniques SG Big Data	SC 31 yes SG Big Data yes SC 32 yes
Data Management Services	SC 32 - Data Management and Interchange	
Document Description Languages	SC 34 - Document Description and Processing Languages	
Information Interchange Media	SC 11 - Flexible Magnetic Media for Digital Data Interchange SC 23 - Optical Disk Cartridges for Information Interchange	
Multimedia and Representation	SC 24 - Computer Graphics and Image Processing SC 29 - Coding of Audio, Picture, and Multimedia and Hypermedia Information	SC 29 yes WG 10 IoT yes SC 06 yes
Networking and Middleware	WG10 – Internet of Things SC 06 - Telecommunications and Information Exchange Between Systems SC 25 - Interconnection of Information Technology Equipment SC 38 - Cloud Computing and Distributed Platforms	SC 38 yes SC 28 yes
Office Equipment	SC 28 - Office Equipment	
Green IT	SC 39 – Sustainability for an by IT	
Programming Languages and Software Interfaces	SC 22 - Programming Languages, their Environments and Systems Software Interfaces	
Security	SC 27 - IT Security Techniques SC 37 - Biometrics	SC 27 yes SC 37 yes
Software, Processes and Systems	SC 07 - Software and System Engineering SC40 – IT Governance and IT Management	SC 07 yes SC 40 yes
Smart Cities	SG Smart City	SG Smart City yes

Consumer Preliminary view for discussion

Technology areas sourced from JTC 1 Systems Integration Guidelines V 1.0

Editor's note: Please note that a new working-group on Big data is established: JTC 1 WG 9 Big data (it is not an SG any more), and work is being undertaken on social media in JTC 1/SC 37 WG 6 Cross-Jurisdictional and Societal Aspects of Biometrics.

A2.3 ISO Committees responsible for aspects of consumer goods and services and so potentially being involved in context setting for consumer privacy needs

Note: There is a need to prioritize which of these areas has the greatest impact on consumer privacy.

- ISO/TC 20 Aircraft and space vehicles
- ISO/TC 21 Equipment for fire protection and fire fighting
- ISO/TC 22 Road vehicles
- ISO/TC 29 Small tools
- ISO/TC 31 Tyres, rims and valves
- ISO/TC 34 Food products
- ISO/TC 38 Textiles
- ISO/TC 42 Photography
- ISO/TC 68 Financial services
- ISO/TC 76 Transfusion, infusion and injection, and blood processing equipment for medical and pharmaceutical use
- ISO/TC 83 Sports and other recreational facilities and equipment
- ISO/TC 84 Devices for administration of medicinal products and catheters
- ISO/TC 86 Refrigeration and air-conditioning
- ISO/TC 92 Fire safety
- ISO/TC 94 Personal safety -- Protective clothing and equipment
- ISO/TC 106 Dentistry

ISO/TC 122 Packaging
 ISO/TC 126 Tobacco and tobacco products
 ISO/TC 133 Clothing sizing systems - size designation, size measurement methods and digital fittings
 ISO/TC 136 Furniture
 ISO/TC 137 Footwear sizing designations and marking systems
 ISO/TC 145 Graphical symbols
 ISO/TC 148 Sewing machines
 ISO/TC 149 Cycles
 ISO/TC 150 Implants for surgery
 ISO/TC 162 Doors and windows
 ISO/TC 168 Prosthetics and orthotics
 ISO/TC 173 Assistive products for persons with disability
 ISO/TC 174 Jewellery
 ISO/TC 178 Lifts, escalators and moving walks
 ISO/TC 180 Solar energy
 ISO/TC 181 Safety of toys
 ISO/TC 188 Small craft
 ISO/TC 204 Intelligent transport systems
 ISO/TC 205 Building environment design
 ISO/TC 207 Environmental management
 ISO/TC 210 Quality management and corresponding general aspects for medical devices
 ISO/TC 211 Geographic information/Geomatics
 ISO/TC 215 Health informatics
 ISO/TC 216 Footwear
 ISO/TC 219 Floor coverings
 ISO/TC 222 Personal financial planning
 ISO/TC 225 Market, opinion and social research
 ISO/TC 228 Tourism and related services
 ISO/TC 232 Learning services outside formal education
 ISO/TC 241 Road traffic safety management systems
 ISO/TC 242 Energy Management
 ISO/PC 245 Cross-border trade of second-hand goods
 ISO/PC 252 Natural gas fuelling stations for vehicles
 ISO/TC 254 Safety of amusement rides and amusement devices
 ISO/TC 257 Evaluation of energy savings
 ISO/TC 260 Human resource management
 ISO/TC 264 Fireworks
 ISO/TC 268 Sustainable development in communities
 ISO/TC 269 Railway applications
 ISO/PC 273 Customer contact centres
 ISO/TC 274 Light and lighting
 ISO/PC 283 Occupational health and safety management systems
 ISO/PC 288 Educational organizations management systems - Requirements with guidance for use
 ISO/TC 290 Online reputation
 ISO/TC 291 Domestic gas cooking appliances
 ISO/TC 292 Security and resilience

A2.4 ISO Committees representing areas that might process PII and so potentially being involved in context setting for consumer privacy needs

ISO/TC 46	Information and documentation
ISO/TC 69	Applications of statistical methods
ISO/TC 70	Internal combustion engines
ISO/TC 121	Anaesthetic and respiratory equipment
ISO/TC 130	Graphic technology
ISO/TC 146	Air quality
ISO/TC 147	Water quality
ISO/TC 154	Processes, data elements and documents in commerce, industry and administration
ISO/TC 159	Ergonomics
ISO/TC 163	Thermal performance and energy use in the built environment
ISO/TC 171	Document management applications
ISO/TC 176	Quality management and quality assurance
ISO/TC 184	Automation systems and integration
ISO/TC 194	Biological and clinical evaluation of medical devices
ISO/TC 199	Safety of machinery
ISO/TC 203	Technical energy systems
ISO/TC 212	Clinical laboratory testing and in vitro diagnostic test systems
ISO/TC 224	Service activities relating to drinking water supply systems and wastewater systems - Quality criteria of the service and performance indicators
ISO/TC 251	Asset management
ISO/TC 262	Risk management
ISO/TC 267	Facilities management
ISO/TC 272	Forensic sciences
ISO/PC 277	Sustainable procurement
ISO/PC 278	Anti-bribery management systems
ISO/TC 279	Innovation management
ISO/PC 280	Management Consultancy
ISO/TC 282	Water re-use
ISO/PC 286	Collaborative business relationship management -- Framework
ISO/TC 289	Brand evaluation
ISO/PC 294	Guidance on unit pricing
ISO/PC 295	Audit data collection
ISO/TC 299	Robotics

Annex 3 Background Material

More detail about these needs is available in 5 ANEC Privacy Guides to be found at:

1. Key Privacy Principles (from the consumer perspective):
<http://www.anec.eu/attachments/ANEC-ICT-2015-G-007.pdf>
2. Key Principles for digitally connected devices privacy impact assessment :
<http://www.anec.eu/attachments/ANEC-ICT-2015-G-008.pdf>
3. Domestic Privacy and the privacy of digitally connected devices :
<http://www.anec.eu/attachments/ANEC-ICT-2015-G-064.pdf>
4. Using Consumer Data – Data transfer, trading and privacy
<http://www.anec.eu/attachments/ANEC-ICT-2015-G-040.pdf>
5. Using Consumer Data (personal data analysis)
<http://www.anec.eu/attachments/ANEC-ICT-2015-G-009.pdf>

Template

Proposal for new work

ISO COPOLCO

GUIDANCE

	SECTION & TITLE	GUIDE
1	Proposer's details	<p><i>Provide Proposer's contact details and associated national standards body/organization for use in correspondence.</i></p> <p>Working Group on Consumer Protection in the Global Marketplace.</p> <p>Bill Dee, Chair</p> <p>compliance@ozemail.com.au</p>
2	Description of problem	<p><i>What is the problem/need?</i></p> <p>“Sharing” economy platforms (which are mostly – in fact – for profit-business models) have seen rapid growth and adoption by consumers in recent years. These platforms have created innovative new models to match buyers with sellers, usually in an environment that also facilitates greater trust among marketplace participants. These platforms have also led to disruption in traditional industry models, as well as the need to re-examine how (or whether) existing regulatory frameworks should capture consumer-to-consumer transactions that are facilitated by a platform. Though embraced by many consumers, the sharing economy may raise new issues in terms of consumer protection, anti-competitive behaviour and disruptions to current employment models.</p> <p>The sharing economy offers both opportunities and challenges to consumers and to consumer protection policy makers. New digital platforms, such as in the urban transport and vacation accommodations sectors, are causing disruptions for established service providers. Some of those new platforms are purporting to operate outside of established regulatory regimes. Typically, the online platforms have a global scale and reach (operating in multiple jurisdictions), but may have</p>

	<p>different applications and be differently regulated at the local level. Some of the key issues from the consumer perspective may be as follows:</p> <ul style="list-style-type: none">• Safety of and access to services as providers do not easily “fit” within established regulatory regimes (such as services that have not been subject to safety inspections or those that do not meet accessibility requirements). There is a heavy reliance on online rating and review systems to build consumer trust. While consumers clearly value peer reviews, it is not clear whether such peer reviews can be considered an adequate substitute for local safety inspections. In addition, the credibility and accuracy of the review systems remains unproven (note that ISO/COPOLCO members are involved in the development of a standard addressing online reviews – TC 290).• Varying local legal obligations, user liability and consumer risk issues, given that certain users providing services via sharing economy platforms may be unaware of their liabilities, obligations and rights (e.g., may not be adequately insured), and consumers may not fully understand what risks have been transferred to them.• A number of platforms require consumers and providers to submit a considerable amount of information, and it is unclear how well these platforms align with national or subnational data protection and privacy laws.• Research shows that a number of platforms require lengthy and complex contractual agreements.• Communications about, and the advertising practices of, a number of platforms could arguably create confusion.• Redress may be difficult to obtain in instances where transactions go wrong. Certain platforms
--	---

		<p>may not to be subject to local consumer protection regimes.</p> <ul style="list-style-type: none"> • Definitions of consumer, buyer and seller are clouded in sharing economy transactions, and many shared services do not always involve the exchange of money as part of the payment. <p><i>What is the evidence?</i></p> <p>Sharing economy platforms are a fairly recent phenomenon and evidence of widespread consumer detriment is limited. However, the fact that many of the transactions do not easily align with existing regulatory models can raise concerns as described above.</p> <p>The sheer volume of consumer demand may be providing the evidence needed to support conclusions about whether the benefits associated with such platforms (income generation and micro-entrepreneurship, accessibility and ease of use, better consumer experience, better choice/variety/price, social experience etc.), outweigh the potential risks.</p> <p><i>Is it generic or sector specific?</i></p> <p>The phenomenon is generic but the platforms and activities are heavily concentrated on the services sector.</p>
3	Need for standard	<p>It may be premature to recommend the development of an international standard at this time. However, ISO/COPOLCO should examine this unique phenomenon that is having such a profound impact on consumers and businesses, and determine if standardization may play a role. Some options for a path forward may include, in no particular order, the following:</p> <p>1. Do Nothing. As mentioned, evidence of consumer detriment is very limited at this time and consumers appear to be willing to embrace the perceived benefits in spite of obvious potential risks. Clearer pathways may become more obvious once the marketplace has settled and consumer detriments, if any, become more evident.</p>

	<p>2. Seek More Data and Research The sharing economy, as well as the experiences (both positive and negative) of consumers, is largely limited to anecdotal information or to statistics provided by vested interests (i.e., sharing economy platforms and – to some extent – their competitors).</p> <p>Potential standards solutions will be more strategic and effective if there is a better, more clear understanding of where marketplace failures, if any, are appearing. This may require research that is beyond the capacity of COPOLCO volunteers. Perhaps ISO, within the ISO Academy, could consider contracting with a university or universities to conduct this research.</p> <p>In summary, it may be preferable to conduct some additional research and consultations before embarking on the drafting of a specific proposal for a new ISO standard in this area.</p> <p>3. Consider A Variety of Standards Approaches. This may include a discussion within the working group, the ISO/COPOLCO CAG or the ISO/COPOLCO plenary on the merits of developing new guidance products, codes of conduct or comparative tools in anticipation of consumer, regulator or business demand for such instruments.</p> <p>As this subject can directly relate to the public policy space, care should be taken to ensure that any possible standards development conforms with Annex SO of the ISO/IEC Directives (Principles for developing ISO and IEC standards related to or supporting public policy initiatives).</p> <p>Examples of standards approaches may include, but not be limited to:</p> <ul style="list-style-type: none">- A Code of Conduct for collaborative economy participants- Guidelines for collaborative economy participants- A Customers Charter
--	---

		<ul style="list-style-type: none"> - A guidance standard or consumer guidance/information document on customer satisfaction and corporate social responsibility in the sharing economy - possibly as an extension of ISO 10001-10004 Customer Satisfaction series of standards - An assessment of the potential for amendments to ISO 26000 to include specific guidelines for sharing economy platform owners - A mapping tool that will allow both service providers and consumers an awareness of how their product or service aligns with existing standards or what standards could be developed <p>4. Annual ISO/COPOLCO Plenary and Workshop.</p> <p>Dedicate an entire ISO/COPOLCO Workshop (2017?) to the Sharing Economy.</p>
4	Benefit to community	<p>What is the added value of the work?</p> <p>The internet and digital technologies have taken the sharing, bartering, lending and selling of goods and service to a new level and expanded the sale and reach of peer transactions.</p> <p>This phenomenon appears to be here to stay. Its impacts deserve attention from ISO/COPOLCO members, and all ISO/COPOLCO working groups to determine if standards may have a role in enhancing consumer benefits and minimizing consumer risks without unnecessarily hindering innovation and competition.</p> <p>Is it within COPOLCO's terms of reference?</p> <p>Yes</p>
5	Alignment within ISO	<p>Are any existing standards and technical committees relevant to the proposed area of work?</p>

		<p>ISO TC/290 (online reputation), ISO 26000</p> <p>Which COPOLCO working group(s) should be involved?</p> <p>All ISO COPOLCO Working Groups. Lead is with the Working Group on Consumer Protection in the Global Marketplace</p>
6	Personnel & resources	<p>Who is working on the proposal?</p> <p>Who is taking the lead on the proposal's development?</p> <p>(Indicate the key persons, consumer representatives, technical experts or national standards bodies who have agreed to conduct the necessary work.)</p>
7	Timeline	<p>What type of tasks are necessary (e.g. research, monitoring, liaison)?</p> <p>How much time is required to complete the work?</p>

- A. Complete a pre-submission check to ensure that:
- ✓ All sections of the form are complete.
 - ✓ The need for standard and benefit to community is fully articulated and, where possible, quantified.
 - ✓ The personnel, resources and timeline have been completed.
 - ✓ The declaration is complete.
 - ✓ Any supporting documentation is attached to the proposal.
- B. Seek guidance from the ISO/COPOLCO Chair's Group to ensure that all sections of the template have been completed in accordance with requirements.
- C. Submit completed proposal along with all supporting documentation by email to the ISO/COPOLCO Secretariat or the ISO/COPOLCO Chair's Group.

TEMPLATE

1 Proposer's Details

Name: Email: Telephone: Associated NSB/Organization:

2 Description of the Problem

--

3 Need for Standard

--

4 Benefit to Community

--

5 Alignment within ISO

--

6 Personnel & Resources

--

7 Timeline

--

Recommendation by Chair's Group

--

Date submitted: _____

Date of initial review: _____

Date of recommendation: _____

Result of voting

Ballot Information	
Ballot reference	COPOLCO N197
Ballot type	CIB
Ballot title	Proposal for an International Standard on service to vulnerable consumers
Opening date	2016-03-25
Closing date	2016-04-21
Note	<p>This consultation follows up COPOLCO Resolution 8/2015, below. Please respond to the questions below.</p> <p>COPOLCO Resolution 18/2015 <i>Global marketplace working group (2)</i> COPOLCO</p> <p><i>notes</i> the work of British Standards Institution on consumer vulnerability as described in COPOLCO 18/2015,</p> <p><i>invites</i> its members to contact the COPOLCO Secretariat to indicate their interest in participating in any future work in this area,</p> <p><i>requests</i> the Secretary to correspond with the members to gather views and information about the interest and relevance of international work on consumer vulnerability.</p>

Member responses:	
Votes cast (52)	Argentina (IRAM) Australia (SA) Austria (ASI) Bahrain (BSMD) Barbados (BNSI) Botswana (BOBS) Brazil (ABNT) Canada (SCC) Chile (INN) Colombia (ICONTEC) Costa Rica (INTECO) Cyprus (CYS) Czech Republic (UNMZ)

Denmark (DS)
Egypt (EOS)
Germany (DIN)
Ghana (GSA)
India (BIS)
Indonesia (BSN)
Iran, Islamic Republic of (ISIRI)
Ireland (NSAI)
Israel (SII)
Jamaica (BSJ)
Japan (JISC)
Kenya (KEBS)
Malawi (MBS)
Malaysia (DSM)
Malta (MCCAA)
Mauritius (MSB)
Mexico (DGN)
Namibia (NSI)
Netherlands (NEN)
Norway (SN)
Pakistan (PSQCA)
Panama (COPANIT)
Peru (INACAL)
Portugal (IPQ)
Saudi Arabia (SASO)
Serbia (ISS)
Singapore (SPRING SG)
Slovenia (SIST)
South Africa (SABS)
Spain (AENOR)
Sweden (SIS)
Switzerland (SNV)
Thailand (TISI)
Trinidad and Tobago (TTBS)
Turkey (TSE)
United Kingdom (BSI)
United States (ANSI)
Uruguay (UNIT)
Zimbabwe (SAZ)

Comments submitted (5)

ANEC
Armenia (SARM)
CI
Saint Lucia (SLBS)
Viet Nam (STAMEQ)

Votes not cast (18)

Algeria (IANOR)
Bangladesh (BSTI)
Bulgaria (BDS)
China (SAC)
Ecuador (INEN)
Fiji (DNTMS)
Finland (SFS)
France (AFNOR)
Italy (UNI)
Kazakhstan (KAZMEMST)
Korea, Republic of (KATS)
Oman (DGSM)

Romania (ASRO)
 Russian Federation (GOST R)
 Sri Lanka (SLSI)
 Sudan (SSMO)
 Tunisia (INNORPI)
 United Arab Emirates (ESMA)

Questions:	
Q.1	"Is the "vulnerable consumer" an important issue in your country? "
Q.2	"Should the Consumer protection in the global marketplace working group develop a new activity template on the "vulnerable consumer"?"

Votes by members	Q.1	Q.2
Argentina (IRAM)	Yes	Yes
Australia (SA)	Yes	Yes
Austria (ASI)	Abstain	Abstain
Bahrain (BSMD)	Yes	Yes
Barbados (BNSI)	Abstain	Abstain
Botswana (BOBS)	Yes	Yes
Brazil (ABNT)	Abstain	Abstain
Canada (SCC)	Yes	Yes
Chile (INN)	Yes	Yes
Colombia (ICONTEC)	Yes	Yes
Costa Rica (INTECO)	Yes	Yes
Cyprus (CYS)	Yes	Yes
Czech Republic (UNMZ)	Yes	Yes
Denmark (DS)	Yes	Yes
Egypt (EOS)	Yes	Yes
Germany (DIN)	Yes	No
Ghana (GSA)	Yes	Yes
India (BIS)	Abstain	Yes
Indonesia (BSN)	Yes	Yes
Iran, Islamic Republic of (ISIRI)	Yes	Yes
Ireland (NSAI)	Abstain	Abstain
Israel (SII)	Abstain	Abstain
Jamaica (BSJ)	Abstain	Yes
Japan (JISC)	Yes	Abstain

Kenya (KEBS)	Yes	Yes
Malawi (MBS)	Yes	Yes
Malaysia (DSM)	Yes	Yes
Malta (MCCAA)	Yes	Abstain
Mauritius (MSB)	Yes	Yes
Mexico (DGN)	Yes	Yes
Namibia (NSI)	Yes	Yes
Netherlands (NEN)	Abstain	Abstain
Norway (SN)	Yes	Yes
Pakistan (PSQCA)	Yes	Yes
Panama (COPANIT)	Yes	Undecided
Peru (INACAL)	Yes	Yes
Portugal (IPQ)	Abstain	Abstain
Saudi Arabia (SASO)	Yes	Yes
Serbia (ISS)	Abstain	Abstain
Singapore (SPRING SG)	Abstain	Abstain
Slovenia (SIST)	Yes	Undecided
South Africa (SABS)	Yes	Yes
Spain (AENOR)	Abstain	Abstain
Sweden (SIS)	Abstain	Abstain
Switzerland (SNV)	Abstain	Abstain
Thailand (TISI)	Yes	Yes
Trinidad and Tobago (TTBS)	Yes	Yes
Turkey (TSE)	Yes	Yes
United Kingdom (BSI)	Yes	Yes
United States (ANSI)	Abstain	Abstain
Uruguay (UNIT)	Yes	Yes
Zimbabwe (SAZ)	Abstain	Abstain

Answers to Q.1: "Is the "vulnerable consumer" an important issue in your country? "		
36 x	Yes	Argentina (IRAM) Australia (SA) Bahrain (BSMD) Botswana (BOBS) Canada (SCC) Chile (INN) Colombia (ICONTEC)

		<p>Costa Rica (INTECO) Cyprus (CYS) Czech Republic (UNMZ) Denmark (DS) Egypt (EOS) Germany (DIN) Ghana (GSA) Indonesia (BSN) Iran, Islamic Republic of (ISIRI) Japan (JISC) Kenya (KEBS) Malawi (MBS) Malaysia (DSM) Malta (MCCAA) Mauritius (MSB) Mexico (DGN) Namibia (NSI) Norway (SN) Pakistan (PSQCA) Panama (COPANIT) Peru (INACAL) Saudi Arabia (SASO) Slovenia (SIST) South Africa (SABS) Thailand (TISI) Trinidad and Tobago (TTBS) Turkey (TSE) United Kingdom (BSI) Uruguay (UNIT)</p>
0 x	No	
0 x	Undecided	
16 x	Abstain	<p>Austria (ASI) Barbados (BNSI) Brazil (ABNT) India (BIS) Ireland (NSAI) Israel (SII) Jamaica (BSJ) Netherlands (NEN) Portugal (IPQ) Serbia (ISS) Singapore (SPRING SG) Spain (AENOR) Sweden (SIS) Switzerland (SNV) United States (ANSI) Zimbabwe (SAZ)</p>

<p>Answers to Q.2: "Should the Consumer protection in the global marketplace working group develop a new activity template on the "vulnerable consumer"?"</p>		
33 x	Yes	<p>Argentina (IRAM) Australia (SA) Bahrain (BSMD) Botswana (BOBS)</p>

		Canada (SCC) Chile (INN) Colombia (ICONTEC) Costa Rica (INTECO) Cyprus (CYS) Czech Republic (UNMZ) Denmark (DS) Egypt (EOS) Ghana (GSA) India (BIS) Indonesia (BSN) Iran, Islamic Republic of (ISIRI) Jamaica (BSJ) Kenya (KEBS) Malawi (MBS) Malaysia (DSM) Mauritius (MSB) Mexico (DGN) Namibia (NSI) Norway (SN) Pakistan (PSQCA) Peru (INACAL) Saudi Arabia (SASO) South Africa (SABS) Thailand (TISI) Trinidad and Tobago (TTBS) Turkey (TSE) United Kingdom (BSI) Uruguay (UNIT)
1 x	No	Germany (DIN)
2 x	Undecided	Panama (COPANIT) Slovenia (SIST)
16 x	Abstain	Austria (ASI) Barbados (BNSI) Brazil (ABNT) Ireland (NSAI) Israel (SII) Japan (JISC) Malta (MCCAA) Netherlands (NEN) Portugal (IPQ) Serbia (ISS) Singapore (SPRING SG) Spain (AENOR) Sweden (SIS) Switzerland (SNV) United States (ANSI) Zimbabwe (SAZ)

Comments from Voters		
Member:	Comment:	Date:
Egypt (EOS)	<i>Comment</i>	2016-04-07 10:37:07

We want to protect the consumer and study the reasons for vulnerable consumer and wish strong consumer. EGYPTIAN CONSUMER PROTECTION .		
Indonesia (BSN)	Comment	2016-04-19 11:06:43
Yes. Characteristics of consumer in Indonesia are very heterogeneous, both in terms of geography, socio-economic status. Vulnerable consumer as like women, children, disabled, migrant workers need special attention. To protect vulnerable consumer need a special approach		
Kenya (KEBS)	Comment	2016-04-19 13:51:36
In Kenya, most consumers can be considered to be "vulnerable" hence this subject matter is of importance. Moreso, the 2010 Constitution of Kenya does prominently give the consumers immense rights.		
Malaysia (DSM)	Comment	2016-04-20 10:06:20
Malaysia is experiencing decreasing birth rate, resulting in an ageing population by 2030. Also meaning that Malaysia will be having a large group of vulnerable consumer at year 2030. UN Developing programme also mentioned that 80% of the disabilities live in developing countries World Bank estimates that 20% of the world's poorest people have some kind of disabilities and the statistics shows a steady increase in these numbers. Malaysian person with disabilities act 2008 has governed the disabilities. However, many businesses did not refer to the act while designing or developing products or services for the vulnerable group and the emerging economy and technology has changed the way of living. The world is been telling us to be inclusive, some even come out with a term 'fully inclusive society'. The idea of fully inclusive society is to have an inclusive heart and attitude which must be incorporated in the formal education, and supported by relevant facilities for the special needs and disabilities which are also considered as vulnerable groups. Understanding that the vulnerable consumer is inclusive of consumers that without basic facilities including education and access of information, with great hope the guidance can help to share best practices in protecting vulnerable consumers. Yes, it is important to develop a series of international guidelines on vulnerable consumers to protect the consumer interest of the vulnerable group. However, the scope of the guidelines/ standards should focus more on the protection of consumers than businesses management.		
Panama (COPANIT)	Comment	2016-04-21 17:28:30
A highest percentage of the population in Panama are vulnerable consumers.		
United Kingdom (BSI)	Comment File	2016-04-21 12:32:08
CommentFiles/COPOLCO N197_BSI.doc		

Comments from Commenters		
Member:	Comment:	Date:
ANEC	Comment	2016-04-21 13:20:53
ANEC submits the attached comments.		
ANEC	Comment File	2016-04-21 13:20:53
CommentFiles/COPOLCO N197_ANEC.docx		

Armenia (SARM)	Comment	2016-04-18 15:10:13
1	Is the "vulnerable consumer" an important issue in your country?	Yes
2	Should the Consumer protection in the global marketplace working group develop a new activity template on the "vulnerable consumer"?	Yes
CI	Comment	2016-04-21 17:03:10
Consumers International support the elaboration of an ISO for identifying the needs of vulnerable consumers		
Saint Lucia (SLBS)	Comment	2016-04-21 21:28:24
<p>Saint Lucia would like to submit comments to support the development of new work to focus on vulnerable consumers.</p> <p>Is the "vulnerable consumer" an important issue in your Saint Lucia?Is the "vulnerable consumer" an important issue in your Country:</p> <p>Answer: Yes</p> <p>Should the Consumer protection in the global marketplace working group develop a new activity template on the "vulnerable consumer"?</p> <p>Answer: Yes</p>		
Viet Nam (STAMEQ)	Comment	2016-04-13 04:41:28
<p>1. Yes</p> <p>2. Yes</p>		

GB 001				GE  N 197 Vulnerable consumers.docx		
ANEC 1 002			Question 1	<p>As a European based consumer association, ANEC has consulted its membership about the issue of vulnerable consumers and broad support was expressed for standardisation in this area.</p> <p>ANEC is also working to build a momentum within the European Institutions to put the needs of vulnerable consumers (children, people with disabilities and older people) at the center of EU policies. Based on the position paper we issued in December 2011 we influenced the European Parliament Report on Vulnerable Consumers adopted in May 2012 and the European Commission Communication "Consumer Agenda".</p> <p>On 7 February 2013, the European Consumer Consultative Group (ECCG) approved an ECCG Opinion on consumers and vulnerability,</p>		

				<p>drafted by ANEC and BEUC based on ANEC's position paper on Vulnerable Consumers of December 2011. The aim of the Opinion is to provide a better understanding and increased consideration for all consumers' needs so as to develop an inclusive and targeted policy approach by the European Commission, and in particular in their response to the European Parliament Resolution a strategy for strengthening the rights of vulnerable consumers of May 2012.</p> <p>The call made by ANEC for standards to be developed to meet the needs of vulnerable consumers has also been taken into account by the European Institutions in several pieces of legislation calling for the standards to implement them to take into account the needs of vulnerable consumers (Lifts Directive, LVD Directive, RED Directive). These new provisions, which will be applicable in the coming months, should set the legal basis for safety and accessibility</p>		
--	--	--	--	--	--	--

				<p>standards to meet the needs of all consumers.</p> <p>The 3rd European Standardisation Summit, held on 11 June 2014 in Istanbul, was dedicated to the theme of how standardisation can support the silver economy. To mark the event, ANEC published the Position paper 'Wiser standards for an ageing world'.</p> <p>In February 2016, the European Commission published the study, 'Consumer vulnerability across key markets in the European Union'. The study follows the European Consumer Consultative Group's Opinion on consumers and vulnerability, drafted by ANEC and BEUC further to ANEC's position paper on Vulnerable Consumers of December 2011. The aim of the Opinion was to provide a better understanding and increased consideration for all consumers' needs, so as to develop an inclusive and targeted policy approach by the EC.</p> <p>The EC study looks into the</p>		
--	--	--	--	--	--	--

				<p>difficulties consumers face in getting the best or fairest deals. It identifies the main reasons behind this vulnerability and considers what can be done to enable consumers to make better use of their rights and the alternatives the marketplace offers. <i>ANEC hopes the study will help the Commission to develop the right legislative, policy and standardisation approach to address consumer vulnerabilities. We are ready to contribute to this important task.</i></p> <p>On the standardisation front, ANEC was at the forefront of the revision of the standards on the safety of household appliances (IEC and EN 60335) to take into account the needs of vulnerable consumers. The previous version of the EN 60335 standards contained an exclusion or limitation clause that these standards do not "..., in general, take into account the use of appliances by young children or infirm persons without supervision." In Europe the work has come to an</p>		
--	--	--	--	---	--	--

					end and it represents a huge step forward for the safety of European consumers, especially children, older people & those with disabilities. We know look at IEC to follow the same way.		
ANEC 2 003			Question 2		<p>ANEC supports the development of a new activity template on the "vulnerable consumer" and we would like to make the following suggestions/background documents to be considered in addition to the information provided above, based on the feedback from our members:</p> <ul style="list-style-type: none"> -In February 2015, the UK's Financial Conduct Authority (UK major regulator for the finance industry) published a report ("Consumer Vulnerability - Occasional Paper No 8") in which the scale of vulnerability in the UK is made very clear in the context of financial services. - Centre for Consumers and Essential Services Consumer Vulnerability – Mainstream, not Marginal 		

					<p>http://www2.le.ac.uk/departments/law/research/cces/copy_of_consume rvulnerability2016.pdf</p> <p>-Ofgem and vulnerable consumers http://www2.le.ac.uk/departments/law/research/cces/ofgem-and-vulnerable-consumers</p> <p>-And What is consumer vulnerability http://consumers.ofcom.org.uk/disability/consumer-vulnerability/</p> <p>-Vulnerability A PhonepayPlus Discussion Document https://www.phonepayplus.org.uk/~media/Files/PhonepayPlus/Research/Vulnerability-discussion-document-2015.pdf</p> <p>- Greek standard ΕΛΟΤ 1439:2013 «Οργανισμός φιλικός σε πολίτες με αναπηρία - Απαιτήσεις και συστάσεις» (organisations friendly to people with disabilities- needs and recommendations.</p>		
--	--	--	--	--	---	--	--

D:\ISO\data\prod_iso_comment-collation\work\temp\COPOLCO N197_ANEC.docx: Collation successful

D:\ISO\data\prod_iso_comment-collation\work\temp\COPOLCO N197_BSI.doc: Collation successful

Collation of files was successful. Number of collated files: 2

SELECTED (number of files): 2

PASSED TEST (number of files): 2

FAILED TEST (number of files): 0

CCT - Version 4.0/2015

BSI Consumer & Public Interest Network comments on:

For vote by 21 April – N 197 Vulnerable consumers

This is clearly very much in tune with the current Safeguarding agenda in the UK, and in the view of CPIN, certainly something we should support. There are clear links between the vulnerability issues and some aspects of the accessibility agenda.

The Discussion Paper seems stronger on identifying the key issues than the draft outline for the standard which seems somewhat watered down by comparison. The draft for the standard needs to address all the points raised in the Discussion Paper.

All consumers are vulnerable and are becoming increasingly so, in the face of the massive industrialisation of marketing, merchandising, advertising and product/services design. Information essential to inform consumers is being replaced by blurb and marketing-speak, image replacing substance and fiction replacing fact. The Supply Side has created a climate of myths and stories to hard sell its products, often based on celebrity culture which exploits a major consumer weakness - the predilection for presentation over content. Consumers can sometimes be their own worst enemies and they do need protection. The Discussion Paper leaves out lack of education as a factor in consumer vulnerability, other than mentioning literacy; lack of mathematical ability should be included (relevant to shopping, particularly for financial services). Low income is mentioned as a vulnerability factor in the Discussion Paper but this should be extended to include poverty, deprivation and poor health, both mental and physical.

In many circumstances, vulnerable consumers will have a measure of protection through existing standards and regulations; any new overarching standard like this one proposed will have to plug some of the gaps –as many as is feasible. Lack of sound accessible information must be addressed but the consumer protection framework is now becoming so complex that specific measures must be taken to facilitate consumer understanding and the need for consumers to thread their way through the maze of often overlapping standards and regulations. It must not be assumed that consumers will always act rationally: as the Discussion Paper points out (but the draft standard does not cover) consumers need protection after, as well as before, they take wrong decisions.

The CPIN has been promoting BS 18477 far and wide for the last few years and think that it would work well as the basis for a European or international standard.

In the UK, there is a growing understanding of consumer vulnerability, and the wide range of factors that can cause it. Some of these are circumstantial, but organizational systems and procedures can actually exacerbate the problem.

Identifying and responding to consumer vulnerability is increasingly important for businesses. As the service industry develops, organizations have to look for different ways to

stand out and differentiate themselves from their competitors. First it was price, then customer service. Now organizations are having to go above and beyond this - trying to win new customers, or keep existing ones, by demonstrating their values and principles of service. Sustainability is one example. Inclusive service is another.

The issues are more about inclusive service than 'vulnerable consumers' as such. It is about recognising that each consumer is an individual, with different needs and abilities, and organizations should adopt a flexible approach that is able to adapt to suit the requirements of each person, rather than a 'one size fits all' approach.

This can actually be beneficial to organizations in the long term, as it means each customer is getting what they want and need, thereby reducing the occurrence of problems and subsequent complaints. In the UK we've seen forward-thinking organizations moving towards this model - in healthcare, financial services and utilities. Regulators are encouraging organizations to take this approach.

The CPIN believes the UK should strongly support this proposal!

Result of voting

Ballot Information	
Ballot reference	COPOLCO N196
Ballot type	CIB
Ballot title	Consultation on Financial Literacy for Youth
Opening date	2016-03-25
Closing date	2016-04-21
Note	<p>The Consumer protection in the global marketplace working group had submitted a new activity template on financial literacy for youth to COPOLCO for advance information at the Plenary meeting in 2015 (Annex 2 to COPOLCO 18/2015). It has since undertaken consultations with the COPOLCO Chair's Group as agreed.</p> <p>There being no further amendments to the proposal, the Global marketplace working group is now consulting the wider COPOLCO membership to gauge support for the proposal.</p>

Member responses:	
Votes cast (53)	Argentina (IRAM) Australia (SA) Austria (ASI) Bahrain (BSMD) Barbados (BNSI) Botswana (BOBS) Brazil (ABNT) Canada (SCC) Chile (INN) Colombia (ICONTEC) Costa Rica (INTECO) Cyprus (CYS) Czech Republic (UNMZ) Denmark (DS) Egypt (EOS) Germany (DIN) Ghana (GSA) India (BIS) Indonesia (BSN) Iran, Islamic Republic of (ISIRI) Ireland (NSAI) Israel (SII)

	Jamaica (BSJ)
	Japan (JISC)
	Kenya (KEBS)
	Malawi (MBS)
	Malaysia (DSM)
	Malta (MCCAA)
	Mauritius (MSB)
	Mexico (DGN)
	Namibia (NSI)
	Netherlands (NEN)
	Norway (SN)
	Pakistan (PSQCA)
	Panama (COPANIT)
	Peru (INACAL)
	Portugal (IPQ)
	Saudi Arabia (SASO)
	Serbia (ISS)
	Singapore (SPRING SG)
	Slovenia (SIST)
	South Africa (SABS)
	Spain (AENOR)
	Sweden (SIS)
	Switzerland (SNV)
	Thailand (TISI)
	Trinidad and Tobago (TTBS)
	Tunisia (INNORPI)
	Turkey (TSE)
	United Kingdom (BSI)
	United States (ANSI)
	Uruguay (UNIT)
	Zimbabwe (SAZ)
Comments submitted (3)	Armenia (SARM)
	Saint Lucia (SLBS)
	Viet Nam (STAMEQ)
Votes not cast (17)	Algeria (IANOR)
	Bangladesh (BSTI)
	Bulgaria (BDS)
	China (SAC)
	Ecuador (INEN)
	Fiji (DNTMS)
	Finland (SFS)
	France (AFNOR)
	Italy (UNI)
	Kazakhstan (KAZMEMST)
	Korea, Republic of (KATS)
	Oman (DGSM)
	Romania (ASRO)
	Russian Federation (GOST R)
	Sri Lanka (SLSI)
	Sudan (SSMO)
	United Arab Emirates (ESMA)

Questions:

Q.1	"Does your country support this template for submission as a New Work Item Proposal?"
Q.2	"If the NWIP is approved, is your NSB likely to nominate an expert? "
Q.3	"If the NWIP is approved, would your NSB consider providing the secretariat?"

Votes by members	Q.1	Q.2	Q.3
Argentina (IRAM)	Abstain	No	No
Australia (SA)	Yes	Undecided	No
Austria (ASI)	Abstain	Abstain	Abstain
Bahrain (BSMD)	Yes	Undecided	Undecided
Barbados (BNSI)	Abstain	Abstain	Abstain
Botswana (BOBS)	Yes	No	No
Brazil (ABNT)	Abstain	Abstain	Abstain
Canada (SCC)	Yes	No	No
Chile (INN)	Abstain	Abstain	No
Colombia (ICONTEC)	Yes	Yes	No
Costa Rica (INTECO)	No	No	No
Cyprus (CYS)	Yes	Undecided	Abstain
Czech Republic (UNMZ)	Yes	No	No
Denmark (DS)	Yes	Undecided	No
Egypt (EOS)	Yes	Abstain	Abstain
Germany (DIN)	No	No	Abstain
Ghana (GSA)	Yes	Undecided	No
India (BIS)	Yes	Yes	Undecided
Indonesia (BSN)	No	No	No
Iran, Islamic Republic of (ISIRI)	Yes	Yes	Undecided
Ireland (NSAI)	Abstain	Abstain	Abstain
Israel (SII)	Abstain	Abstain	Abstain
Jamaica (BSJ)	Yes	Undecided	Abstain
Japan (JISC)	Abstain	No	No
Kenya (KEBS)	Yes	Yes	Undecided
Malawi (MBS)	Yes	Yes	Yes
Malaysia (DSM)	No	No	No
Malta (MCCAA)	Abstain	No	No
Mauritius (MSB)	Abstain	Abstain	No

Mexico (DGN)	Yes	No	No
Namibia (NSI)	Yes	Undecided	Undecided
Netherlands (NEN)	Abstain	Abstain	Abstain
Norway (SN)	Yes	No	No
Pakistan (PSQCA)	Yes	Yes	No
Panama (COPANIT)	Undecided	Undecided	Undecided
Peru (INACAL)	Yes	Yes	Yes
Portugal (IPQ)	Abstain	Abstain	Undecided
Saudi Arabia (SASO)	Yes	Undecided	Undecided
Serbia (ISS)	Yes	No	No
Singapore (SPRING SG)	Abstain	Undecided	Abstain
Slovenia (SIST)	Yes	No	No
South Africa (SABS)	Yes	Undecided	No
Spain (AENOR)	Abstain	Abstain	No
Sweden (SIS)	Abstain	Abstain	Abstain
Switzerland (SNV)	Abstain	Abstain	Abstain
Thailand (TISI)	Abstain	Undecided	Undecided
Trinidad and Tobago (TTBS)	Yes	No	No
Tunisia (INNORPI)	Yes	Yes	Undecided
Turkey (TSE)	Yes	Undecided	Undecided
United Kingdom (BSI)	Yes	Yes	Yes
United States (ANSI)	Abstain	Abstain	Abstain
Uruguay (UNIT)	Abstain	No	No
Zimbabwe (SAZ)	Abstain	Abstain	Abstain

Answers to Q.1: "Does your country support this template for submission as a New Work Item Proposal?"

28 x	Yes	Australia (SA) Bahrain (BSMD) Botswana (BOBS) Canada (SCC) Colombia (ICONTEC) Cyprus (CYS) Czech Republic (UNMZ) Denmark (DS) Egypt (EOS) Ghana (GSA) India (BIS) Iran, Islamic Republic of (ISIRI)
-------------	------------	--

		Jamaica (BSJ) Kenya (KEBS) Malawi (MBS) Mexico (DGN) Namibia (NSI) Norway (SN) Pakistan (PSQCA) Peru (INACAL) Saudi Arabia (SASO) Serbia (ISS) Slovenia (SIST) South Africa (SABS) Trinidad and Tobago (TTBS) Tunisia (INNORPI) Turkey (TSE) United Kingdom (BSI)
4 x	No	Costa Rica (INTECO) Germany (DIN) Indonesia (BSN) Malaysia (DSM)
1 x	Undecided	Panama (COPANIT)
20 x	Abstain	Argentina (IRAM) Austria (ASI) Barbados (BNSI) Brazil (ABNT) Chile (INN) Ireland (NSAI) Israel (SII) Japan (JISC) Malta (MCCAA) Mauritius (MSB) Netherlands (NEN) Portugal (IPQ) Singapore (SPRING SG) Spain (AENOR) Sweden (SIS) Switzerland (SNV) Thailand (TISI) United States (ANSI) Uruguay (UNIT) Zimbabwe (SAZ)

Answers to Q.2: "If the NWIP is approved, is your NSB likely to nominate an expert? "

9 x	Yes	Colombia (ICONTEC) India (BIS) Iran, Islamic Republic of (ISIRI) Kenya (KEBS) Malawi (MBS) Pakistan (PSQCA) Peru (INACAL) Tunisia (INNORPI) United Kingdom (BSI)
16 x	No	Argentina (IRAM)

		Botswana (BOBS) Canada (SCC) Costa Rica (INTECO) Czech Republic (UNMZ) Germany (DIN) Indonesia (BSN) Japan (JISC) Malaysia (DSM) Malta (MCCAA) Mexico (DGN) Norway (SN) Serbia (ISS) Slovenia (SIST) Trinidad and Tobago (TTBS) Uruguay (UNIT)
13 x	Undecided	Australia (SA) Bahrain (BSMD) Cyprus (CYS) Denmark (DS) Ghana (GSA) Jamaica (BSJ) Namibia (NSI) Panama (COPANIT) Saudi Arabia (SASO) Singapore (SPRING SG) South Africa (SABS) Thailand (TISI) Turkey (TSE)
15 x	Abstain	Austria (ASI) Barbados (BNSI) Brazil (ABNT) Chile (INN) Egypt (EOS) Ireland (NSAI) Israel (SII) Mauritius (MSB) Netherlands (NEN) Portugal (IPQ) Spain (AENOR) Sweden (SIS) Switzerland (SNV) United States (ANSI) Zimbabwe (SAZ)

Answers to Q.3: "If the NWIP is approved, would your NSB consider providing the secretariat?"		
3 x	Yes	Malawi (MBS) Peru (INACAL) United Kingdom (BSI)
24 x	No	Argentina (IRAM) Australia (SA) Botswana (BOBS) Canada (SCC) Chile (INN)

		Colombia (ICONTEC) Costa Rica (INTECO) Czech Republic (UNMZ) Denmark (DS) Ghana (GSA) Indonesia (BSN) Japan (JISC) Malaysia (DSM) Malta (MCCAA) Mauritius (MSB) Mexico (DGN) Norway (SN) Pakistan (PSQCA) Serbia (ISS) Slovenia (SIST) South Africa (SABS) Spain (AENOR) Trinidad and Tobago (TTBS) Uruguay (UNIT)
11 x	Undecided	Bahrain (BSMD) India (BIS) Iran, Islamic Republic of (ISIRI) Kenya (KEBS) Namibia (NSI) Panama (COPANIT) Portugal (IPQ) Saudi Arabia (SASO) Thailand (TISI) Tunisia (INNORPI) Turkey (TSE)
15 x	Abstain	Austria (ASI) Barbados (BNSI) Brazil (ABNT) Cyprus (CYS) Egypt (EOS) Germany (DIN) Ireland (NSAI) Israel (SII) Jamaica (BSJ) Netherlands (NEN) Singapore (SPRING SG) Sweden (SIS) Switzerland (SNV) United States (ANSI) Zimbabwe (SAZ)

Comments from Voters		
Member:	Comment:	Date:
Colombia (ICONTEC)	<i>Comment</i>	2016-04-20 17:32:09
Ms. Sandra Herrera, sherrera@icontec.org		

Egypt (EOS)	Comment	2016-04-07 10:26:56
This proposal is very interest and important		
Germany (DIN)	Comment	2016-04-21 16:01:30
DIN Counsumer Cuncil does not support that NWIP DIN Consumer Council will not nominate an expert		
Indonesia (BSN)	Comment	2016-04-19 11:03:06
We agree to educate our youth through their schools to increase knowledge about financial products and services, mostly on banking		
Malawi (MBS)	Comment	2016-04-19 17:54:14
We find the New Work Item Proposal very important and if standards are indeed developed to address these issues it will help a lot including here in developing countries. Young people will be provided with international best practices in terms of financial management. MBS could consider but the only constraint would be on resources to run the secretariat.		
Malaysia (DSM)	Comment	2016-04-20 10:00:11
No- financial education for young generation is definitely important and it is important to be included into the existing curricular. However, measurement on how well the young generation are financially literate is not appropriate because personal financial management is not suppose only taught in formal education but also taught in early education from the parents or even the spending habits of the adults as a role model.		

Comments from Commenters		
Member:	Comment:	Date:
Armenia (SARM)	Comment	2016-04-18 14:54:59
1	Does your country support this template for submission as a New Work Item Proposal?	Yes
2	If the NWIP is approved, is your NSB likely to nominate an expert?	Undecided
3	If the NWIP is approved, would your NSB consider providing the secretariat?	Abstain
Saint Lucia (SLBS)	Comment	2016-04-21 21:22:02
Saint Lucia supports work on finacial literacy for youth as part of general consumer education and awareness standards.		

We are not able at this time to nominate an expert to serve on such committee but will follow such work closely if it is approved.

Viet Nam (STAMEQ)	<i>Comment</i>	2016-04-13 04:40:18
1.Yes 2. Yes 3.No		

N196 Consultation on Financial Literacy for Youth

Questions and answers

<u>No.</u>	<u>Questions</u>	<u>Possible Answers</u>
1	Does your country support this template for submission as a New Work Item Proposal?	<p>Yes</p> <p>No</p> <p>Undecided</p> <p>Abstain</p>
	<p>Our Country supports this template as a NWIP on Financial literacy for youth as this would help our national young consumers of today where:</p> <ul style="list-style-type: none"> i. It can be seen as investment in human capital; ii. It would be a social optimal to raise the financial knowledge for everyone in early life; iii. When a young consumer understands financial concept and products, they are more informed of making financial decision. iv. Having access to financial services v. Financial literacy and informed choice vi. Ethics in financial services 	
2	If the NWIP is approved, is your NSB likely to nominate an expert?	<p>Yes</p> <p>No</p> <p>Undecided</p> <p>Abstain</p>
	<p>Our NSB will not be able to nominate an expert due to financial constraints. However, we would definitely like to be an Observer for this NWIP.</p>	
3	If the NWIP is approved, would your NSB consider providing the secretariat?	<p>Yes</p> <p>No</p> <p>Undecided</p> <p>Abstain</p>
	<p>The NSB is undergoing review of the Department right now to strengthen and streamline procedures and processes and to align to international best practices. There are human resource capacity constraints and as such we would not be able to be the secretariat.</p>	

N197 Proposal for an International Standard on service to vulnerable consumers

Questions and answers

<u>No.</u>	<u>Questions</u>	<u>Possible Answers</u>
1	Is the "vulnerable consumer" an important issue in your country?	Yes No Undecided Abstain

It is an important issue in my country as this issue exist and having this as a standard:

- i. Would help public/private sector in knowing more of how to identify and set in place policies/processes to provide services to those that require special needs.**
- ii. For consumers to take the responsibility in making right decision on goods and services they purchase.**
- iii. A vulnerable consumer may be someone who is disadvantaged when they are unable to access the product or service they require, or they are required to expend a disproportionate amount of effort to access the product or service. Consumers may experience a specific vulnerability throughout their lifetime or at specific times in their lives, such as being vulnerable due to financial hardship or illness.**
- iv. Access for all. The importance of inclusive services.**

- 2 Should the Consumer protection in the global marketplace working group develop a new activity template on the "vulnerable consumer"?
- Yes**
No
Undecided
Abstain
- i. Would help consumers to be responsible for their decisions and**
- ii. Increase consumers' confidence**



International Organization for Standardization
Organisation internationale de normalisation
Международная организация по стандартизации

AGENDA ITEM 13 PRODUCT SAFETY WORKING GROUP



AGENDA ITEM 13 COPOLCO PRODUCT SAFETY WORKING GROUP REPORT

Co-Chairs: Dr. Eunsook Moon, Korea, mooneu21@gmail.com
Ms. Karin Both, Germany karin.both@din.de

Mandate:

- to promote the design, manufacture, assembly, sale and disposal of safer consumer products via COPOLCO and ISO
- to develop greater consistency and coherence in requirements for safety in Standards
- to encourage networking and communication between COPOLCO and ISO members and to coordinate with IEC on safety issues for common areas of interest on issues of safety and emerging issues
- to respond to calls for information and advice on product safety issues.

Membership: 20 countries (as of 2015 May)

Table) List of members

#	Name of country	NSB	#	Name of country	NSB
1	Argentina	IRAM	11	Israel	SII
2	Australia	SA	12	Italy	UNI
3	Canada	SCC	13	Japan	JISC
4	Chile	INN	14	Korea	KATS
5	China	SAC	15	Malaysia	DSM
6	Denmark	DS	16	Netherland	MEN
7	France	AFNOR	17	South Africa	SABS
8	Germany	DIN	18	Switzerland	SNV
9	India	BIS	19	UK	BSI
10	Iran	ISIRI	20	US	ANSI

Introduction

At the ISO/COPOLCO meeting convened in May in 2015, the Working Group on Product Safety held a fringe meeting to discuss and to prioritize issues as identified by the Working Group and confirm overall future directions. The summary of this meeting was presented to the COPOLCO 37th Plenary and it was ratified by COPOLCO Resolutions 13/2015, 14/2015, 15/2015 and 16/2014.

2015 COPOLCO RESOLUTIONS

COPOLCO Resolution 13/2015

Product safety working group (1)

COPOLCO

approves the report of the Product safety working group (PS WG) at COPOLCO 17/2015,

notes the continued input from the PS WG into the revision and promotion of ISO/IEC Guides,

further notes the revisions in 2014 of:

- ISO/IEC Guide 50, *Safety aspects – Guidelines for child safety in standards and other specifications*
- ISO/IEC Guide 51, *Safety aspects – Guidelines for their inclusion in standards*, and Page 5
- ISO/IEC Guide 71, *Guide for addressing accessibility in standards*;

thanks the Product safety working group members for their contributions in these areas.

COPOLCO Resolution 14/2015

Product safety working group (2)

COPOLCO

notes the submission of the new work item proposals, ISO/IEC 82079-2 Preparation of instructions – *Structuring, content and presentation - Part 2 - Provisions for instructions for self-assembly products*; and *Choking hazards of small component parts* to ISO TC 10 for ballot,

further notes positive comments, but non-acceptance of these proposals due to an insufficient nomination of experts, and the decision of ISO/TC 10 to forward NWIP ISO/IEC 82079-2 to IEC/TC 3 for further consideration and ballot closing on 7 August 2015.

decides to resubmit the NWIP, *choking hazards of small component parts* for consideration by another technical committee, such as ISO/TC 122, *Packaging*.

COPOLCO Resolution 15/2015

Product safety working group (3)

COPOLCO

thanks the Product safety working group for their scoping document on *Quantification of risk assessments*, appearing at Annex 1 to COPOLCO 17/2015,

notes comments made on the proposal, and the proposal to appoint a task group to redraft it,

invites the product safety working group to resubmit the draft for further consideration of members,

recognizes the importance of other safety issues presented in COPOLCO 17/2015,

further invites the group to submit a progress report for members' consideration at the 2016 COPOLCO meeting.

COPOLCO Resolution 16/2015

Product safety working group (4)

COPOLCO

thanks ANEC for its report on issues relating to safety of products appearing at COPOLCO 25/2015, Page 6

strongly supports ANEC's campaign to delete the exclusion clause from the parent IEC 60335 standards, and other standards for consumer products,

further supports lowering of surface temperature limits in the IEC 60335 series of standards,

invites members with the national representation in IEC/TC 108 to support ANEC on safety issues relating to audio-video equipment.

PS WG ACTIVITY UPDATES in 2016

A. NWIPs in action

1 Inadequacies of instructions for maintenance and assembly

- The Issue

The PS WG identified a number of safety issues regarding the inadequacy of instructions for assembly and maintenance for products. Rather than script a new Guide, the Working Group decided to raise this safety aspect for inclusion in existing guides that have a focus relating to instructions.

Confusing instructions, instructions that are not concise, lack of maintenance instructions for products, incorrect translation, misleading or contradictory information, and lack of information about deterioration due to the weather, particularly in extreme climates, can result in incorrect or unsafe assembly

- Progress

Under the leadership of Dr. Gabriela Fleischer (Germany), the NWIP was edited and submitted to the ISO TMB in July 2014. Upon receipt the TMB secretariat decided this would be best dealt with via a direct submission to ISO TC 10.

IEC 82079-2 Preparation of instructions – Structuring, content and presentation – Part 2 - Provisions for instructions for self-assembly products,

The NWIP was also submitted to IEC TC 3 for consideration, but rejected officially by ISO as well as by IEC due to lack of nominated experts in 2015.

IEC TC3, Information structures and elements, identification and marking principles, documentation and graphical symbols

- Actions

The PSWG decided to approach the convener (Dr. Gabriela Fleischer) of ISO/IEC JWG 16. This JWG was founded to revise IEC 82079-1. The idea was to ask for the inclusion of the content of the ISO COPOLCO NWIP in the revision of IEC 82079-1.

IEC 82079-1:2012 Preparation of instructions for use -- Structuring, content and presentation -- Part 1: General principles and detailed requirements

ISO/IEC JWG 16 Maintenance of IEC 82079 series. To monitor the needs for revision of the IEC 82079: Preparation of instructions for use - Structuring, content and presentation

According to update from ISO/IEC JWG 16, IEC TC 3 discussed this proposal at the plenary meeting in November 2015 and proposed that the main aspects of the NWIP should be integrated in the revision of IEC 82079-1. In the Working Draft of IEC 82079-1 Ed.2, an annex for self-assembly products was introduced.

At the 4th meeting in March 2016, ISO/IEC JWG 16 decided that the annex was too comprehensive and should be condensed to general requirements. JWG 16 also decided that it should be inserted in the main body of the Committee Draft of the IEC 82079-1 Ed.2.

2. Choking hazards of small component parts

- The issue

Since the introduction of plastic bottles (disposable and re-usable) with a “sports cap” that a user can close and open with his/her teeth, some manufacturers have received complaints that parts of the cap could be accidentally inhaled and cause a potential choking hazard. There has been similar concern that the end-caps of USB memory sticks, which may be shaped like toys or other child-appealing designs, could pose a potential choking hazard to infants and young children in the same way as detachable parts of toys.

Existing standards such as the BS Pen Cap Standard and the ISO Toy Standard do not cover these hazards for a wide age range, from adults to children. Nor do they consider the small dimensions and possible attachment to a larger product, such as presented by the cap of a sports drink container.

- Progress

Under the lead of Gordon Hayward (UK), and invited expert Mike Hayes, the scoping document on this topic was ratified to form the basis for a NWIP in 2014.

The NWIP, *Components of consumer products or packaging likely to be removed or held by mouth - Safety requirements and mechanical test methods*, was edited and submitted to the ISO TMB in July 2014. Upon receipt the secretariat decided this new work proposal would be best dealt with via a direct submission to ISO TC 10, for the committee's consideration. The PS WG resubmitted the NWIP to TC 122 (Packaging) and they responded that it was not in the scope of the committee.

- Actions

For the next step, it was forwarded to COPOLCO/WG 16, Revision of ISO/IEC Guide 41, *Packaging -- Recommendations for addressing consumer needs*

The members of the Product Safety working group will be asked to send evidence to the co-chairs and secretariat of COPOLCO. Based on evidence and comments from members, BSI experts will consider further actions.

- Reference

Standards Australia, *HB 295.3.25-2008 Product Safety Framework, Part 3.25: Choking from small parts* (See Annexes 1, 2).

B. NEW PROJECTS in discussion

Risk Management of Consumer Product Safety

- The issue

SAC (China) proposed a possible new standard explaining a mathematical model for calculating risk assessments.

Justification for new international standard provided by SAC; Guide 51, ISO 31000 and the Safety Guide for Manufacturers present principles only and are less feasible in implementation. A new international standard will comprise detailed articles on the method of calculating safety risk evaluation for consumer products which will offset the lack of feasibility in present safety evaluations of consumer products in the world.

- Progress

SAC has drafted a template submission (General Principles for Risk Management of Consumer Product Safety) as a new topic for evaluation as a possible NWIP for consideration.

There was, in general, support for the proposal, noting that it has a good intention although it relies heavily on existing standards and guides. Some members questioned whether we require more critical guidance, given the excellent references that are in current use. As another suggestion, the

proposal could be forwarded to ISO/TC 262 and be possibly considered in a revision of applicable standards.

ISO/TC 262 Risk management

ISO 31000:2009 Risk management - Principles and guidelines

IEC 31010:2009 Risk management - Risk assessment techniques

- Actions

Upon a request of PS WG for clarification, SAC re-drafted the originally submitted template and further discussion will be invited at the plenary meeting to decide further action on this proposal. Another option for further action is using the relevant content of the proposal to be considered when the ISO 10377 and ISO 10393 (product recall) are up for systematic review in 2018. (See Annex 3)

- References

The list of references on Risk Assessment Methodologies in the ISO 10377: 2013 Consumer product safety -- Guidelines for suppliers is as follows:

- [45] *Applying the R-Map Method to Product Safety and Risk Management*, Japan
- [46] EMARS, *Best Practice Techniques in Market Surveillance*, <http://www.emars.eu/>
- [47] *European Commission Decision of January 26, 2010, Risk Assessment Guidelines for Non-food Consumer Products*, <http://europa.eu/sanco/rag/help/Journal.pdf>
- [48] *European Commission Risk Assessment Guidelines for Consumer Products* contained in Commission Decision of 16 December 2009 EC 2010/15/EU: *Laying down guidelines for the management of Community Rapid Information System 'Rapex' established under Article 12 and of the notification procedure established under Article 11 of Directive 2001/95/EC (the General Product Safety Directive)*
- [49] *European Commission, Establishing a Comparative Inventory of Approaches and Methods Used by Enforcement Authorities for the Assessment of the Safety of Consumer Products Covered by Directive 2001/95/EC on General Product Safety and Identification of Best Practices*, February 2006.
- [50] *IEC Advisory Committee on Safety, Development of a standard for safety related risk assessment in the area of low voltage*
- [51] *Product Safety in Europe: A Guide to Corrective Action Including Recalls* ec.europa.eu/consumers/cons_safe/action_guide_en.pdf

C. NEW ISSUES under consideration

1. E-cigarettes

- The issue

E-cigarettes are becoming more popular and aside from the very high risks of the chargers (many domestic fires caused by faulty chargers), there are concerns about the product itself - the nicotine and access by children, other chemicals present in the e-cigarettes and what the vapour may or may not be doing to bystanders. It was further noted there has already been one death of a child from accessing nicotine in an e-cigarette in the UK.

- Progress

ISO TC 126 (Tobacco and tobacco products) Subcommittee 3 (Vape and vapour products)
ISO/TC 126/SC 3/WG 2 Routine analytical e-cigarette vaping machine

- Actions

Watching brief.

Acknowledged as a serious safety issue. Submission to the Key areas WG will be shared.

- Reference

“Vape and vapour products make their debut in international standardization”

http://www.iso.org/iso/home/news_index/news_archive/news.htm?refid=Ref2074

A comment on the safety of vape products from our Facebook page

<https://www.facebook.com/BettyBoop091687/posts/10153994954187936>

2. Nappy Sacks

- The issue

Nappy sacks are scented plastic bags used to contain then discard used disposable nappies. This product can cause death via suffocation and we see this is a foreseeable use since a child would be attracted to a scented bag. The plastic sacks are very tactile and scented, and babies and toddlers are drawn to them. With no breathing holes, these sacks present an ideal hazard that can easily result in suffocation.

- Progress

It was noted that ISO/IEC Guide 41 (Packaging) is currently under revision and may be able to address the problem. The PS WG contacted the Chair of the Guide 41 revision group to raise this matter.

- Actions

It was forwarded to the working group revising ISO/IEC Guide 41, *Packaging - Recommendations for addressing consumer needs*

3. Liquitabs/washing pods

- **The issue**

Liquid laundry detergent capsules or 'laundry pods' contain highly concentrated liquid detergent in water-soluble packaging that releases on contact with moisture. Laundry capsules are small and often colorful, making them attractive to young children.

A child can easily burst the laundry capsule and release the entire contents onto the skin or mouth with only a small amount of saliva or pressure. Irritation incidents are occurring and there can be more serious chemical burns of the mouth and lungs if the contents are ingested, although manufacturers have taken action in making pods opaque and harder to open,

- **Progress**

On the EU level, **COMMISSION REGULATION (EU) No 1297/2014** covers safety of liquitabs/laundry detergent capsules and their packaging sold in the EU (See Annex 4). The regulation lays down the following requirements.

- take more than six seconds to dissolve
- have a coating that is impregnated with a bittering agent
- packaged in non-transparent boxes
- packaged in boxes that are printed with warnings and have a child-resistant closing mechanism

This new regulation came into effect on 1 June 2015. Manufacturers have been given six months to comply with the new regulations:

There is also an ASTM committee on this issue and OECD has been conducting global campaign on this as well to make them bitter and less attractive.

Up to now **ISO/TC 91 Surface active agents** did not cover safety topics and had not discussed the problem of liquitabs.

- **Actions**

Members have acknowledged this as a serious safety issue at the May 2015 meeting. Shall we consider proceeding to a new activity template?

D. WATCHING BRIEF PROJECTS

1. Vertical axis top loading washing machines

Upon the request of China (CN, IEC National Committee) for additional safety requirements regarding opening of the lid or door during spinning, IEC TC 61 (*Safety of household and similar electrical appliances*) decided to create the new WG 38 at the Nov. 2015 meeting.

IEC TC 61/WG 38 (60335-2-7 Washing machines) will prepare a DC to cover additional requirements for top loading agitator and impeller-type washing machines for restarting the spin cycle after stopping it by lifting the lid.

The scope of WG 38 is restricted to safety requirements during spinning. Nevertheless, it is a good chance for the Product Safety Working Group to have oversight of vertical axis top loaders, if additional safety requirements are needed such as complete cessation of the agitator when the lid is lifted, automatic emptying of water when the lid is lifted, etc.

More information on IEC TC 61 WG 38 60335-2-7 (*Household and similar electrical appliances - Safety - Part 2-7 Particular requirements for washing machines - Washing machines*):
http://www.iec.ch/dyn/www/f?p=103:14:0:::FSP_ORG_ID,FSP_LANG_ID:13190,25

The PSWG would like to suggest that consumer representatives actively participate in IEC TC 61/WG 38.

2. Lithium button cell batteries

No further work at this stage until current international work is concluded.

3. 3 D printing

SA developed an activity template for the Key Areas WG (See Annex 5) Related link: <http://www.iso.org/sites/hitechstandards/>

4. Drones

It was confirmed to refer the issue to the Global Marketplace WG. Related link: <http://www.iso.org/sites/hitechstandards/>

5. Other issues and information (See Annex 6)

- Safety of ride-on toys
- Toy safety standards

Annex 1 – HB 295.3.25-2008 Product Safety Framework

Annex 2 – Part 3.25: Choking from small parts

Annex 3 – General Principles for Risk Management of Consumer Product Safety

Annex 4 – 1297-2014 – Liquitabs

Annex 5 – Activity Template on 3D Printing

Annex 6 – Correspondence on safety of ride-on toys

(Draft resolution overleaf)

Annex 7 - Matrix of Activity in 2015

COPOLCO Resolution x/2016

Product safety working group (1)

COPOLCO

approves the report of the Product safety working group (PS WG) at COPOLCO N212/2016,

notes the continued work projects of the PS WG,

approves the development of a new activity template on liquitabs,

notes the submission at Annex 3 to COPOLCO N212, *General Principles for Risk Management of Consumer Product Safety*,

approves the development of a new work item proposal based on this submission,

OR

requests the PS WG to prepare a recommendation to take account of the contents of this submission within the revisions of ISO 31000, *Risk management -- Principles and guidelines*, ISO 10393, *Consumer product recall -- Guidelines for suppliers*, and ISO 10377, *Consumer product safety -- Guidelines for suppliers*.



**DRAFT AGENDA - Product Safety working group - 16 June 2016 – Mövenpick Hotel,
Geneva, Switzerland, starting at 09:00**

Item	Topic	Document	Rapporteur
1.	Welcome and introductory remarks		Co-Chairs
2.	Adoption of the agenda		Co-Chairs
3.	Report on PS WG Activity updates 1) NWIP in action 2) New projects in discussion 3) New issues under consideration 4) Watching brief projects	N38	
4.	Discussion of 2016 work programme	N38	
5.	New consumer product safety concerns from members		From the floor
6.	Any other business		From the floor
7.	Concluding remarks – actions summary		Co-Chairs

Australian Handbook

Product Safety Framework

Part 3.25: Choking from small parts

AIM

This Part of the PSF applies to any part of a product which is liberated from that product or any product itself which could be regarded as small enough to be regarded as a choking hazard.

The intent of this Part is to remove the possibility of a small part which is incorporated into a product or forms a product in itself being accessible to a vulnerable user who may place the product in their mouth and put themselves at risk of choking.

This Part suggests a standard testing mechanism for determining whether the product or liberated part is in fact small enough to be regarded as a potential choking hazard and requires a small parts cylinder.

This GRM does require technical expertise. This means that it does require specialized qualifications, skills, training and/or equipment or facilities to determine compliance.

PREFACE

This GRM is based on the requirements of AS/NZS ISO 8124.1:2002 *Safety of toys—Safety aspects related to mechanical and physical properties*.

This GRM is a constituent part of the Product Safety Framework process. It is intended to be used in conjunction with HB 295.1.

REQUIREMENTS

R1 CHOKING FROM SMALL PARTS

R1.1 Small parts test

Removable components and components liberated during testing shall not fit entirely, whatever their orientation, into the small parts cylinder when tested in accordance with T1.1.



R1.2 Test for shape and size of portions of product

No part of the product shall penetrate past the full depth of the cavity of the template when tested in accordance with T1.2.

TEST PROCEDURES

T1 CHOKING FROM SMALL PARTS

T1.1 Small parts test

Place any removable component, without compressing it and in any orientation, into the cylinder as shown in Figure 1.

Repeat the procedure with any component liberated during testing.

If any removable component or component liberated during testing can fit into the cylinder in one or more orientations then it is considered to be a hazardous component.

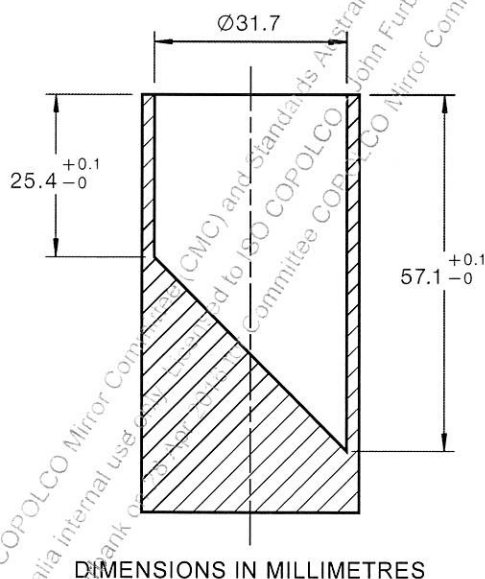

FIGURE 1 SMALL PARTS CYLINDER

T1.2 Test for shape and size of portions of product

Position and clamp the test template A shown in Figure 2 so that the axis of the slot is essentially vertical and the slot is unobstructed at its top and bottom openings.

Orient the product to be tested in a position which would most likely permit the entry of the product through the slot in the test template. Place the product in the slot in the orientation stated so that the force on the product is only the force attributable to its weight.

Determine whether any part of the product penetrates past the full depth of the cavity of the test template.

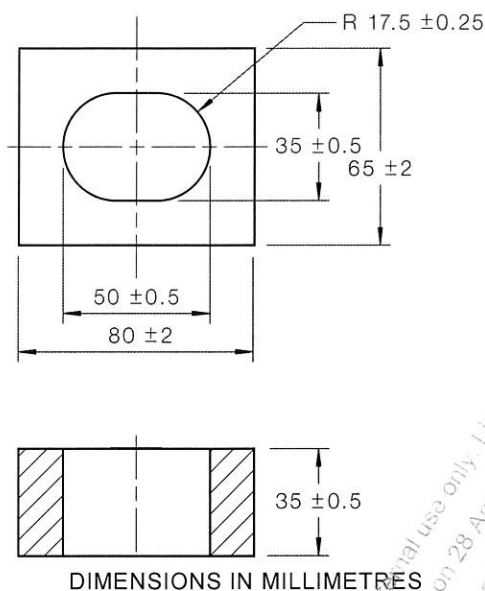

FIGURE 2 TEST TEMPLATE A

Repeat the procedure for products with nearly spherical, hemispherical or circular flared ends using supplemental test template B shown in Figure 3, except that only the spherical, hemispherical or circular flared ends shall be presented to the template.

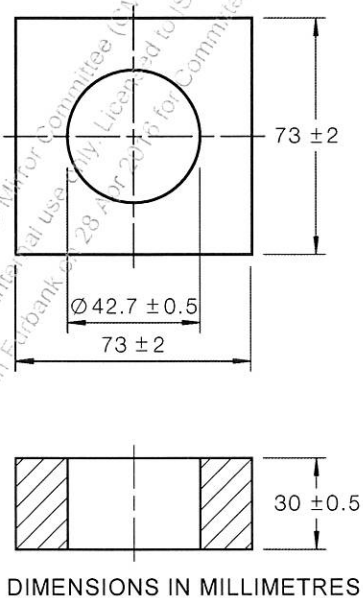

FIGURE 3 TEST TEMPLATE B

For information regarding the development of Standards contact:

Standards Australia Limited
GPO Box 476
Sydney NSW 2001
Phone: 02 9237 6000
Fax: 02 9237 6010
Email: mail@standards.org.au
Internet: www.standards.org.au

For information regarding the sale and distribution of Standards contact:

SAI Global Limited
Phone: 13 12 42
Fax: 1300 65 49 49
Email: sales@sai-global.com

First published as HB 295.3.25—2007.
Second edition 2008.

COPYRIGHT

© Standards Australia

All rights are reserved. No part of this work may be reproduced or copied in any form or by any means, electronic or mechanical, including photocopying, without the written permission of the publisher.

Published by Standards Australia Limited
GPO Box 476, Sydney, NSW 2001, Australia

STANDARDS AUSTRALIA

RECONFIRMATION

OF

HB 295.3.25—2008

Product Safety Framework

Part 3.25: Choking from small parts

RECONFIRMATION NOTICE

Technical Committee CS-112 has reviewed the content of this publication and in accordance with Standards Australia procedures for reconfirmation, it has been determined that the publication is still valid and does not require change.

Certain documents referenced in the publication may have been amended since the original date of publication. Users are advised to ensure that they are using the latest versions of such documents as appropriate, unless advised otherwise in this Reconfirmation Notice.

Approved for reconfirmation in accordance with Standards Australia procedures for reconfirmation on 4 February 2016.

The following are represented on Technical Committee CS-112:

Australian Chamber of Commerce and Industry
 Australian Competition and Consumer Commission
 Centre for Accident Research and Road Safety – Queensland
 Consumers Federation of Australia
 Council of Textile and Fashion Industries of Australia
 Kidsafe
 Office of Fair Trading (QLD)

ICS 13.120.00

A 20

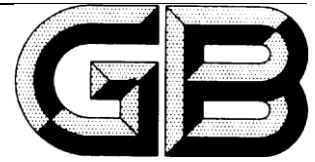

National Standards of the People's Republic of China

GB/T 2014-XXXX

**General Principles for Risk Management of
Consumer Product Safety**

Issued on 2014

Be effective from upon 200

Issued by

Contents

General Principles for Risk Management of Consumer Product Safety错误!未定义书签。

General principles for risk management of consumer product safety	i
Contents	I
Preface.....	II
Foreword.....	III
1 Scope.....	1
2 Glossary and Definition.....	1
3 Risk Management Procedures for Consumer Product Safety	6
4 Early-stage Preparation	8
5 Hazard Identification	11
6 Risk Estimation	12
7 Risk Evaluation	14
8 Risk Control	16
9 Risk Communication	18
Appendix A.....	19
Appendix B.....	26
Appendix C	28
Appendix D	57
Appendix E.....	58
Appendix F.....	59
References.....	62

Preface

Appendix A, B, C, D, E and F in this standard is the literature for reference.

Foreword

The Standard is the general principles in risk evaluation of consumer product safety and can work as the guide for risk evaluation of consumer product safety in related fields.

EU regulations, international standards, national standards, and industrial standards and applicable literature have worked as reference in the formulation of the Standard.

Appendix A and B list out the categories of consumer product hazards and injuries respectively, which can work as reference in specifying the category of hazard and injury in hazard identification process.

Appendix C lists out the instance of general methods for risk evaluation of consumer product safety, which can work as reference in the selection of risk evaluation methods for consumer product safety.

Appendix D and E list out the instance of the methods for the possibility estimation of consumer product injury and risk grade division of consumer product hazard, which can work as reference for the possibility estimation of consumer product injury and risk grade division of consumer product hazard.

Appendix F lists out the instances for the risk control method of life cycle of consumer product safety, which can work as reference for the selection of risk control method of life cycle of consumer product safety.

The Guidelines for Risk Management of Consumer Product Safety

1 Scope

The Standard stipulates the **principles, contents, procedures and methods** for the safety and risk management in the life cycle of consumer product.

The Standard is applicable for the risk evaluation of consumer product safety by related parties on different phases of the life cycle of consumer product.

2 Glossary and Definition

The following glossary and definitions are applicable in the Standard.

2.1

Consumer Product

It mainly includes the product designed and produced for (while not limited to) the use of individuals, including the groupware, components, fittings, packaging and instruction book of the product.

[ISO 10377: 2013, Definition 2.2]

2.2

Consumer

The individuals in public, purchasing or using the property, product or service for personal purpose.

[ISO 26000: 2010, Definition 2.2]

2.3

Injury

Physical injury or damage to human health, or loss of the property.

(Source: ISO/IEC Guide 51: 1999, 3.3, Reversion)

2.4

Vulnerable Consumers

Consumers in face of high injury risk, with no access to product safety information due to the age, education background and physical conditions (or restrictions).

[ISO 10377: 2013, Definition 2.30]

2.5

Hazard

Potential source triggering off the injury

Note 1: the hazard defined herein can be determined according to the source and the nature of anticipated injury (such as electric shock hazard, biologic hazard, breakup hazard, cutting hazard, poisonous hazard, fire hazard and drowning hazard).

(Source: ISO/IEC Guide 51: 1999, 3.5)

2.6

Hazardous Event

The event triggering off an injury in case of hazard.

(Source: ISO/IEC Guide 51: 1999, 3.4)

2.7

Hazardous Situation

The situation where the human body or property is exposed to one or more hazards.

(Source: ISO/IEC Guide 51: 1999, 3.6, Reversion)

2.8

Risk

General term for the possibility and serious degree of the injury.

(Source: ISO/IEC Guide 51: 1999, 3.2)

2.9

Consumer Product Safety

The status where the unacceptable risk of consumer product is prevented.

[GB/T 28803-2012, Definition 3.4]

2.10

Consumer Product Life Cycle

The whole process of the consumer product, covering the design, production, packaging, storage, transport, use (including repair) and recovery.

[GB/T 28803-2012, Definition 3.5]

2.11

Foreseeable Error Use

Incorrect or improper use of the product can be anticipated or known in advance on the basis of thorough knowledge of suppliers toward the product and human behavior. For example: the improper use by infants or the old.

[ISO 10377: 2013, Definition 2.6]

2.12

Unforeseeable Error Use

The use of some product in a mode, which is impossible for supplier to know or the supplier can hardly predict on its full discretion.

[ISO 10377: 2013, Definition 2.28]

2.13

Tolerable Risk

The risk that some specific user group can accept according to the prevailing social values.

Note 1: in this international standard, “acceptable risk” and “tolerable risk” are synonyms.

(Source: ISO/IEC Guide 51: 1999, 3.7, Reversion)

2.14

Hazard Identification

The process where the risk factor is detected, and listed out and described.

[GB/T 28803-2012, Definition 3.7]

Note 1: the factors can include source or hazard (source), event, consequence and possibility.

Note2: hazard identification can also reflect the issues that the interest-related persons are concerned about.

2.15

Risk Reduction

The behavior reducing the negative consequence of risk and/or lowering its occurring possibility.

[GB/T 23694-2009, Definition 3.4.4]

2.16

Risk Control

The behavior implementing the risk management decision.

Note: risk control may include decision monitoring, reevaluation and implementation.

[GB/T 23694-2009, Definition 3.4.2]

2.17

Risk Management

Adoption of coordinated behavior for guiding and controlling the risk that the organization is confronted with.

(Source: ISO/IEC Guide 73: 2009, 2.1)

2.18**Risk Estimation**

The process of value assignment for the possibility of injury and graveness degree of its consequence.

[GB/T 22760-2008, Definition 2.8]

2.19**Risk Analysis**

The accessible information is systematically applied for hazard identification and risk prediction.

(Source: ISO/IEC Guide 51: 1999, 3.10)

2.20**Risk Evaluation**

The process determining if the risk decreases to tolerable degree on the basis of risk analysis.

(Source: ISO/IEC Guide 51: 1999, 3.11)

2.21**Risk Assessment**

The whole process including risk analysis and risk evaluation.

(Source: ISO/IEC Guide 51: 1999, 3.12)

2.22

Risk Communication

The decision maker and other interest-related persons exchange and share the information about the risk.

(Source: ISO/IEC Guide 73: 2002, 3.2.4 Reversion)

2.23

Corrective Action

The actions taken for eliminating potential hazard and reducing the risk.

Note: in this international standard, corrective action refers to “recall” because the public and media are likely to accept and respond to this expression.

(Source: ISO 10393: 2013, 2.4)

3 Risk Management Procedures for Consumer Product Safety

3.1 Risk Management Principles for Consumer Product Safety

3.1.1 Highlight on Consumer Safety

The risk management shall highlight the human body and property safety when the consumers use consumer product, especially some special prevention and protection for vulnerable consumers (such as the aged, children and the disabled).

3.1.2 Throughout Consumer Product Life Cycle

The risk management shall be done on the basis of consumer product life cycle, so as to prevent potential risk and control consumer product injury in the use of consumer product within tolerable scope.

Note: for the category of injury, see Appendix B for reference.

3.1.3 Emphasis on Information Acquisition

The process of risk management shall be based upon valid information, which can be obtained via many channels including prevailing standards, regulations, experiments and expert judgments while the limitation of the information shall be taken into account.

3.1.4 Optimal Selection Method

Systematic and structural methods shall be taken in risk management for improving the efficiency of risk management and generating consistent, comparable and reliable result.

3.1.5 Continuous Improvement

The risk management of consumer product safety includes the activities such as risk analysis, risk evaluation, risk control and risk communication, is the process continuously lowering the risk and the dynamic process adapting to the change of the environments and has the everlasting target of continuous improvement. Administrative, law, standard, regulation and other remedy measures shall be taken for gradually improving the risk of consumer product safety.

3.1.6 Wide Participation

The communication between the interest-related persons in risk management shall be strengthened. Particularly, the decision makers shall participate in risk management in proper way in due time for ensuring the pertinence and efficiency of risk management.

3.2 Risk Management Workflow of Consumer Product Safety

The risk management workflow of consumer product safety shall take into account inherent characteristics, diversities and complexity of consumer product. The technique or method applied in various activities may involve multidisciplinary issue and integrated use of quantitative or qualitative methods. The risk management workflow of consumer

product safety usually includes the steps as follows. See Figure 1:

- a) Early-stage preparation (See Article 4 for details)
- b) Hazard identification (See Article 5 for details)
- c) Risk estimation (See Article 6 for details)
- d) Risk evaluation (See Article 7 for details)
- e) Risk control (See Article 8 for details)

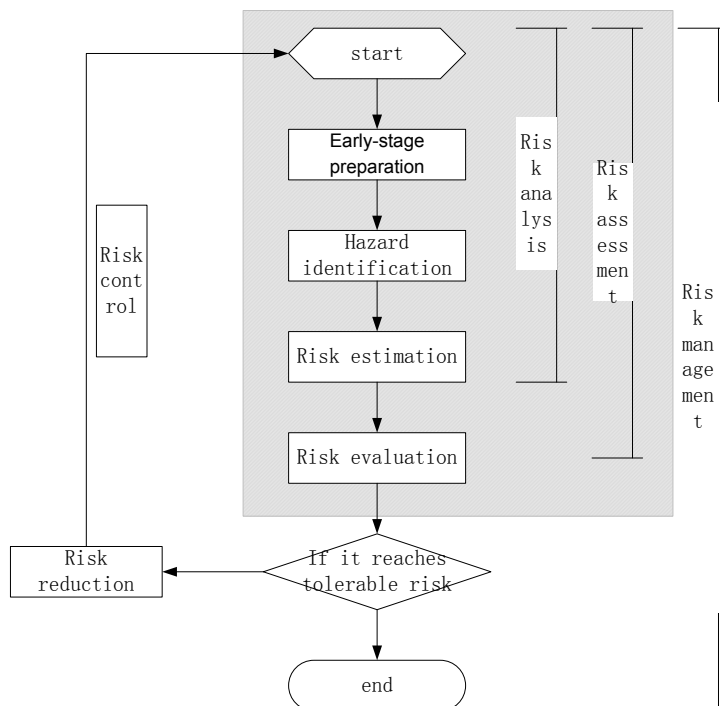

Note: the shadow part in Figure 1 is the risk assessment workflow of consumer product safety.

Figure 1 Risk Management Workflow Chart of Consumer Product Safety

4 Early-stage Preparation

In the early-stage preparation, the targets, and applicable management and technical preparations for carrying out risk management of consumer product safety can be defined. The specific tasks shall include: work-out of risk management plan, definition of tolerable risk and preparation of internal and external information.

4.1 Work-out of Risk Management Plan

Risk management plan shall be part of risk management document, and be defined according to the characteristics of some specific consumer product and formulated in the

document.

A risk management plan shall at least include:

- a) Target of risk management;
- b) Definition of the risk management scope of consumer product;
- c) Risk management staff and their responsibilities and powers;
- d) Risk management method;
- e) Validation of risk management plan.

4.2 Identification of Tolerable Risk

The criteria for identifying tolerable risk includes (while is not limited to) the items as follows:

a) Applicable domestic & international laws, regulations and standards on consumer product safety;

b) Public research literature on the risk assessment of potential hazard of consumer product safety;

Note: for the category of hazards, see Appendix B for reference.

c) The literature on risk level of consumer product in expert experiences and research fruits in other subjects;

d) After the influence factors of social and economic development level are taken into account comprehensively, tolerable risk in risk assessment of consumer product safety is specified.

4.3 Internal Information Preparation

Internal information preparation prior to a risk management includes the definition of the information of target consumer product such as service environment, service life, user group and use quantity.

a) Definition of Use Information of Consumer Product

Mainly including:

——User group. The characteristics of the user group (including intended user group, potential user group and non-intended user group) of the target consumer product such as gender, age, education background, physical condition, psychological characteristics and experiences shall be defined, and special attention shall be given to the users vulnerable

to an injury (such as: the aged, children and the disabled);

——Intended use. It shall be defined as the intended use of consumer product under the precondition of no change of properties of consumer product so that risk management work can be done with highlight on the intended use of consumer product;

——Use behavior. It shall define consumer's behaviors in normal use and reasonably foreseeable use during the stipulated service of consumer product;

——Service life. It shall define a probable service life of consumer product in normal use and reasonably foreseeable use by consumers;

——Service environment. It shall take into account the ambient temperature, indoor and outdoor humidity in the use of consumer product. Service environments of consumer product include both normal service environment and reasonably foreseeable non-normal service environment.

——Service time. The duration time for users to use or contact the product.

b) Description of Various Phases of Consumer Product Life Cycle

The technical characteristics of target consumer product on different phases of life cycle are described and recorded in documents.

c) Literature Preparation for Risk Assessment of Target Consumer Product

The literature preparation for risk assessment of target consumer product includes:

——Applicable laws, regulations, standards and other documents;

——Related data and literature on the safety event of consumer product;

——Research fruits related to the safety of target consumer product.

4.4 External Information Preparation

External ambient information includes while is not limited to:

a) Cultural, economic, social, scientific and technological status at home and abroad;

b) The demands of various interest-related parties of the risk management (consumer, government and enterprise);

c) External key factors influencing the risk management activity and their history and evolvement trends.

5 Hazard Identification

5.1 Hazard Identification Channel for Consumer Products

The hazard (source) of consumer product in normal use and reasonably foreseeable misuse is identified.

For the categories of consumer product hazard and injury, see Appendix A and B for reference.

Hazard identification channel of consumer product mainly includes:

- a) The promulgated laws, regulations, and international, domestic and industrial standards and applicable stipulations;
- b) Frontline and independent industrial, technical and scientific knowledge and proposal;
- c) Accident report, injury data and database analysis;
- d) Product recall data obtained from various government or independent channels;
- e) Applicable human engineering theory;
- f) Consumers' complaint and goods return of similar products;
- h) Online discussion group, forum and social media;
- i) Applicable testing report and certificate of the product or raw material;
- j) Opinions of experts;
- k) Other information sources related to the product or similar products.

5.2 Hazard Identification Method

The category, characteristics and function of consumer products shall be considered and the phases of life cycle of consumer products be specified in the hazard identification of consumer product. On various phases of life cycle of consumer product, the potential injury to consumers in the use and reasonably foreseeable use of consumer product shall be identified. For the category of specific injuries, see Appendix A herein for reference.

Hazard identification methods can be divided into two categories. See Figure 2:

- a) Effect-cause method: if potential injury can be determined, the hazard causing the injury can be defined on the basis of the potential injury. That is to say, find out hazardous situation according to the injury firstly, and then the hazard. This method can be used on

various phases of life cycle of consumer product. Specific method is included in Appendix C;

b) Cause-effect method: in case of known hazard, if hazardous situation with potential injury and the process how the hazard triggers off the injury can be set up, the injury can be directly derived out of the hazard. Specific hazard identification method is included in Appendix C.

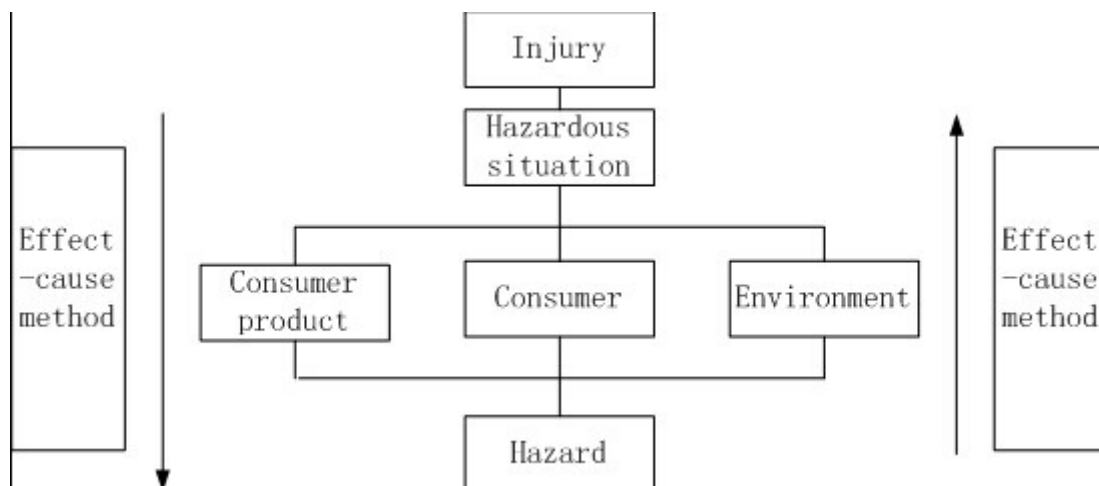

Figure 2 Category of Hazard Identification Methods

6 Risk Estimation

Various methods can be used in risk estimation. No specific method is required in the Standard. However, in case of proper data available, priority shall be given to quantitative risk estimation. In case of no proper data, qualitative risk estimation method can also be applied. The risk estimation methods on various phases of life cycle of consumer product are included in Appendix C. After the hazard is identified, in light of risk factors, the degree of injury shall be estimated in consideration of the injury situation.

6.1 Risk Factor

In general, the combination of risk factors includes the items as follows:

- a) Graveness degree of injury;
- b) Possibility of injury.

6.2 Injury Situation

The array or combination of reasonably foreseeable safety events of consumer product with potential injury shall be taken into account, and the hazardous situation shall be recorded. In general, injury situation mainly includes the items as follows:

- a) Operation mode triggering off the injury;
- b) Type and quantity of the persons involved in hazardous situation;
- c) The time that the consumer spends in injury occurring area;
- d) The frequency that the consumer operates the consumer product;
- e) Category of the injuries in each injury situation;
- f) Protective measures already taken;
- g) Service life of consumer product;
- h) Accumulation effect of consumers exposed in hazardous situation.

6.3 Injury Degree

The injury degree of consumer product for human body is usually divided into four grades i.e. very serious, serious, average and weak. See Table 1.

Table 1 Grades of Injury Degree

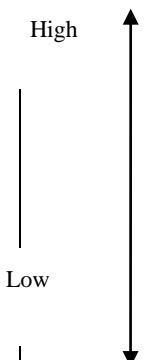
Grades		Characteristics description
High  Low	Very serious	It causes disastrous injury. Such injury may cause death and the disability of human body.
	Serious	It causes irreversible injury (e.g. scar), which shall be treated in emergency treatment department or in hospital. Such injury will cause serious negative impact upon human body.
	Average	The injury can be treated in out-patient service. Such injury has average impact upon human body.
	Weak	The injury can be treated at home, instead of medical treatment while causes some uncomfortable feeling of human body to some extent. Such injury has light impact upon human body.

6.4 Injury Possibility

Some specific hazardous situation of an injury can be divided into several phases, of which each phase corresponds with one potential phase possibility triggering off the injury. The possibility of each phase is indicated in proper probability, and the probabilities of the injury on all phases are multiplied together for deriving a total probability of the injury. The example for the estimation of injury possibility is included in Appendix D.

The information required in calculating the injury possibility is obtained through the channels as follows:

- a) Related history data; b) test simulation; c) experts' judgment.

The injury possibility is usually divided into eight types. See Table 2.

Table 2 Types of Injury Possibility

Possibility		Characteristics description
<div style="display: flex; align-items: center; justify-content: center;"> <div style="text-align: center; margin-right: 10px;"> <p>High</p> <p>↑</p> <p>↓</p> <p>Low</p> </div> </div>	I	Extremely high possibility of hazardous event, repetitively occurring in any case.
	II	Hazardous event frequently occurring.
	III	Some possibility of hazardous event, not low-probability event.
	IV	Some possibility of hazardous event, low-probability event.
	V	Few hazardous events, while low possibility
	VI	Few hazardous events, while extremely low possibility.
	VII	No possibility, while it may occur in few specific cases
	VIII	No hazardous event in any case.
<p>Note: 1. Specific value can be assigned for the grade of injury possibility in the table according to the actual situation.</p> <p>2. If some hazard reaches the degree of seriousness, it goes beyond the scope of tolerable risk for most consumer products no matter the hazard occurs frequently or not.</p>		

7 Risk Evaluation

Risk evaluation refers to the process of identifying the risk grade of consumer product.

7.1 General Requirements for Risk Evaluation

7.1.1 Valid Information

Huge information shall be collected before the risk assessment. During assessment, more surveys and relevant new information are required. The information shall be genuine, reliable and timely.

7.1.2 Combination of Qualitative and Quantitative Methods

Qualitative or quantitative method or both methods can be used in risk assessment. In case of proper data available, priority shall be given to the quantitative method for the risk assessment.

7.1.3 Comprehensive Assessment

The development levels of science, technology, economy and knowledge shall be considered comprehensively in the risk assessment for specifying the tolerable degree of hazard and risk, and the tolerable degree of the risk shall be repetitively assessed in the assessment.

7.2 General Steps for Risk Evaluation

Risk evaluation usually includes the steps as follows:

- a) Assessment of category and graveness degree of possible injury, such as: fatal or non-fatal, serious injury or minor injury;
- b) Prediction of injury probability; and with regard to the behavior of the consumers, the product use frequency and service life of the product shall be considered;
- c) The risk that some specific consumer group is confronted with is predicted as per the identified risk;
- d) Carry out analysis for determining if a grade of risk is influenced by presumption or probability change;
- e) Maintain records on risk evaluation;
- f) Hand over the risk evaluation method and conclusion to experts for validation;

g) In case that a risk isn't controlled within the tolerable scope, the product shall be redesigned for lowering the risk or protective measures against the hazard shall be taken.

7.3 Risk Evaluation Method

In light of some specific hazard, according to the possibility of injury that it may cause as well as degree of injury possibility, the risk grade of consumer product for such hazard can be estimated. A matrix method is usually applied in the definition of the risk grades of consumer product hazard. See Appendix E for reference. The risk evaluation method for consumer product life cycle is included in Appendix C.

In case of two or more hazards for one consumer product, risk evaluation shall be done for each hazard separately, and the highest risk grade of each hazard shall be taken as the safety risk grade of the consumer product.

7.4 Risk Assessment Document

A safety risk assessment of consumer product shall be recorded in documents, with specific items as follows:

- a) Information preparation before risk assessment;
- b) Target of risk assessment;
- c) Category of hazard;
- d) Determination of injury degree;
- e) Identification of injury possibility;
- f) Determination of risk assessment grade;
- g) Impact of uncertainty of the data in use upon the risk assessment.

8 Risk Control

8.1 Target of Risk Control

Hazard identification, risk estimation and risk evaluation are the foundation for the risk management while risk control is ultimate purpose of risk management. Main target of risk control: realize an optimal safety level on the basis of current technical and managerial levels with the least consumption; specific control targets: lower accident frequency, lower graveness degree of the accident and lower economic loss of the accident.

8.2 Basic Principles for Risk Control

a) Closed-loop control principle. The risk control of consumer product life cycle shall include one complete closed-loop control process i.e. input—output—information feedback—control measure—control input.

b) Dynamic control principle. Full knowledge on the dynamic change rule of consumer product life cycle on various phases and the proper control in due time are required for realizing the anticipated effect.

c) Level-by-level control principle. Level-by-level control principle is applied according to the organizational structure of consumer product and the categorization rule of hazards in life cycle so as to realize the targets breakdown, distinct responsibilities and final overall control of the system.

d) Multi-layer control principle. Multi-layer control can improve the safety reliability of consumer product and usually comprise six layers: fundamental preventive control, complementary control, preventive control for preventing expansion of accident, control over maintenance performance, routine control and emergency control. Specific layer of control method in practical application isn't stipulated in the Standard and shall be determined by the work staff as per the degree and seriousness of one hazard.

8.3 Risk Control Method

On various phases of consumer product life cycle, risk control targets shall be defined as per the results of risk assessment, for the purpose of regularizing the responsibilities of operating and managerial staff on different phases, carrying out risk control accordingly, lowering the risk and finally ensuring the tolerable risk. The risk control method on various phases of consumer product life cycle is included in Appendix F.

After the intolerable risk is controlled, the validity of risk control shall be validated.

8.4 Risk Control Report

Risk control report shall include the items as follows:

- a) Report number;
- b) Name of the compiler and the date;
- c) Grade of input risk;

- d) Hazard category and detailed description;
- e) Risk control method;
- f) Grade of output risk;
- g) If it is tolerable risk.

9 Risk Communication

9.1 Purpose of Risk Communication

It aims at transmitting the risk information of consumer product life cycle on various phases in different aspects among interest-related persons so that they will share correct knowledge on existing risk and moreover, take effective preventive control measures for lowering the risk and controlling the risk within the tolerable scope.

9.2 Contents of Risk Communication

The contents of risk communication include the introduction to risk reduction results and the risk management decision and require the joint participation of risk assessor, risk manager, consumer, enterprise, academic body and other interest-related parties.

9.3 Risk Communication Document

The implementing party of risk communication shall set up and maintain series of the documents on risk assessment within the whole life cycle of consumer product and ensure consumer product safety through the risk communication among various interest-related parties of risk management.

9.4 Risk Communication Modes

- a) Survey and interview;
- b) Communication by correspondence;
- c) Electronic communication, such as telephone, network, TV or broadcast;

Additional contents of risk communication and proper communication mode can be added according to the characteristics and demands of various consumer products.

Appendix A

Hazard Category of Consumer Product

Hazard category example of consumer product is included in Table A.1.

Table A.1 Hazard Category Example of Consumer Product

Category	Sub-category	Item	Group
1. Physical hazard	1.1 Mechanical hazard	1.1.1 Form and surface performance hazard	1.1.1.1 Air-tightness 1.1.1.2 Small caduceus parts 1.1.1.3 Pointed angle 1.1.1.4 Sharp edge 1.1.1.5 Smooth surface 1.1.1.6 Rough surface 1.1.1.7 Spacing or opening of parts 1.1.1.8 Others
		1.1.2 Potential energy hazard	1.1.2.1 Low mechanical stability 1.1.2.2 Low mechanical strength 1.1.2.3 Elastic groupware out of control 1.1.2.4 Pressurized space out of control 1.1.2.5 Others
		1.1.3 Kinetic energy hazard	1.1.3.1 Moving status strike 1.1.3.2 Drag of rotating part 1.1.3.3 Flying object strike 1.1.3.4 Moving part extrusion 1.1.3.5 Others
	1.2 Explosion hazard	1.2.1 Gas-phase explosion hazard	1.2.1.1 Explosive gas 1.2.1.2 Explosive dust 1.2.1.3 Explosive spray 1.2.1.4 Others
		1.2.2 Fluid-phase explosion hazard	1.2.2.1 Aggregation explosion 1.2.2.2 Vaporization explosion 1.2.2.3 Fluid mixing explosion 1.2.2.4 Others
		1.2.3 Solid-phase explosion hazard	1.2.3.1 Explosive compound 1.2.3.2 Solid explosive substance 1.2.3.3 Others
	1.3 Noises hazard	1.3.1 Stability noises hazard	
		1.3.2 Mobility noises hazard	
		1.3.3 Pulsive noises hazard	
	1.4 Electric hazard	1.4.1 Electric shock hazard	1.4.1 High/low voltage 1.4.2 Overheat 1.4.3 Electrical leak 1.4.4 short circuit 1.4.5 Others

Category	Sub-category	Item	Group
		1.4.2 Electric explosion	1.4.5.1 Overheat 1.4.5.2 Short circuit 1.4.5.3 Poor contact 1.4.5.4 Heating of iron core 1.4.5.5 Bad heat dissipation 1.4.5.6 Others
		1.5 High/low-temperature substance hazard	1.5.1 High-temperature substance hazard
	1.5.2 Low-temperature substance hazard		1.5.2.1 Low-temperature surface 1.5.2.2 Low-temperature fluid 1.5.2.3 Low-temperature gas 1.5.2.4 Others
	1.6 Radiation hazard	1.6.1 Heat radiation hazard	
		1.6.2 Ray radiation hazard	1.6.2.1 Laser radiation 1.6.2.2 Ultraviolet radiation 1.6.2.3 X-ray radiation 1.6.2.4 Others
		1.6.3 Electromagnetic radiation hazard	1.6.3.1 High-frequency electromagnetic radiation 1.6.3.2 Low-frequency electromagnetic radiation 1.6.3.3 Others
	1.7 Others		
2. Chemical hazard	2.1 Inorganic poison hazard	2.1.1 Poisonous gas hazard	2.1.1.1 Carbon monoxide 2.1.1.2 Nitrous oxide 2.1.1.3 Chlorine 2.1.1.4 Ozone 2.1.1.5 Hydrogen chloride 2.1.1.6 Sulfureted hydrogen 2.1.1.7 Others
		2.1.2 Hazard of poisonous heavy metal and its compounds	2.1.2.1 Arsenic and its compound 2.1.2.2 Cadmium and its compound 2.1.2.3 Chromium and its compound 2.1.2.4 Cuprum and its compound 2.1.2.5 Mercury and its compound 2.1.2.6 Nickel and its compound 2.1.2.7 Lead and its compound 2.1.2.8 Others
		2.1.3 Poisonous acid and alkaline hazard	2.1.3.1 Vitriol 2.1.3.2 Hydrochloric acid 2.1.3.3 Sodium hydroxide 2.1.3.4 Others
		2.1.4 Inorganic cyanide hazard	2.1.4.1 Hydrocyanic acid 2.1.4.2 Potassium cyanide 2.1.4.3 Cyan chloride 2.1.4.4 Others

Category	Sub-category	Item	Group
	2.2 Organic poison	2.2.1 Poisonous aldehyde compound	2.2.1.1 Formaldehyde 2.2.1.2 Acetaldehyde 2.2.1.3 Acraldehyde 2.2.1.4 Others
		2.2.2 Poisonous aromatic fused-ring compounds	2.2.2.1 Anthracene compound 2.2.2.2 Phenanthrene compound 2.2.2.3 Pyrene compound 2.2.2.4 Others
		2.2.3 Poisonous heterocyclic-ring compound	2.2.3.1 N-heterocyclic compound 2.2.3.2 S-heterocyclic compound 2.2.3.3 O-heterocyclic compound 2.2.3.4 Others
		2.2.4 Poisonous organic chloride	2.2.4.1 Organic fluoride 2.2.4.2 Organic chloride 2.2.4.3 Organic bromide 2.2.4.4 Others
	2.3 Others		
3. Biological hazard	3.1 Pathogenic microbe hazard	3.1.1 Prokaryocyte microbe hazard	3.1.1.1 Escherichia coli 3.1.1.2 Salmonella 3.1.1.3 Vibrio Parahemolyticus 3.1.1.4 Staphylococcus aureus 3.1.1.5 Bacillus cereus 3.1.1.6 Others
		3.1.2 Eukaryocyte microbe hazard	3.1.2.1 Dermatophytes 3.1.2.2 Chromomycosis 3.1.2.3 sporotrichosis 3.1.2.4 Cryptococcus neoformans 3.1.2.5 Candida albicans 3.1.2.6 aspergillus 3.1.2.7 Mucor 3.1.2.8 Pneumocystis carinii 3.1.2.9 Others
		3.1.3 Primary microbe hazard	3.1.3.1 Hapatitis A virus 3.1.3.2 Influenza a virus 3.1.3.3 Rotavirus 3.1.3.4 Avian influenza virus 3.1.3.5Others
	3.2 Pathogenic organism hazard	3.2.1 Parasite hazard	3.2.1.1 Dust mite 3.2.1.2 Ascarid egg 3.2.1.3 Tapeworm egg 3.2.1.4 Others
	3.3 Others		

Appendix B

Injury Category of Consumer Product

Hazard category example of consumer product is included in Table B.1

Table B.1 Injury Category Example of Consumer Product

Category	Sub-category	Item
1. Physical property injury	1.1 Blunt instrument (force) injury	1.1.1 Scratch 1.1.2 Contusion 1.1.3 Wrench 1.1.4 Crush injury 1.1.5 Fracture 1.1.6 Internal organ damage or cracking 1.1.7 Limb severing 1.1.8 Others
	1.2 Sharp instrument (force) injury	1.2.1 Chopped wound 1.2.2 Cutting injury 1.2.3 Puncture injury 1.2.4 Shearing injury 1.2.5 Others
	1.3 External force suffocation or in-vivo foreign material injury	1.3.1 Suffocation 1.3.2 In-vivo foreign material 1.3.3 Others
	1.4 High-temperature /Low-temperature substance injury	1.4.1 Burning injury 1.4.2 scald 1.4.3 frostbite 1.4.4 Others
	1.5 Electric shock injury	1.5.1 electric injury 1.5.2 Electric heating scorch 1.5.3 Electric injury syndrome 1.5.4 Others
	1.6 Radiation injury	1.6.1 Eyesight damage 1.6.2 cardiovascular system damage 1.6.3 Genital system damage 1.6.4 Others
	1.7 Noises/vibration injury	1.7.1 Audition damage 1.7.2 Cardiovascular injury 1.7.3 Internal organ damage 1.7.4 Others
	1.8 Explosive substance injury	1.8.1 Explosion injury
	1.9 Others	

2. Chemical property injury	2.1 Chemical stimulation 2.2 Anaphylactic response 2.3 Coma and anaesthesia 2.4 General toxicosis 2.5 Carcinogenesis 2.6 Teratogenesis 2.7 Genetic gene mutation 2.8 Others	
3. Biologic property injury	3.1 Biologic infection 3.2 Biologic poisoning 3.3 Others	

Appendix C

Average Method Example of Safety Risk Assessment of Consumer Product Life Cycle in Common Use

Average method example of safety risk assessment of consumer product life cycle in common use is included in Table C.1.

Table C.1 Average Method Example of Safety Risk Assessment of Consumer Product Life Cycle in Common Use

Risk assessment method	Design phase			Production phase			Packaging phase			Storage & transport phase			Use phase			Recovery phase		
	Hazard identification	Risk estimation	Risk evaluation	Hazard identification	Risk estimation	Risk evaluation	Hazard identification	Risk estimation	Risk evaluation	Hazard identification	Risk estimation	Risk evaluation	Hazard identification	Risk estimation	Risk evaluation	Hazard identification	Risk estimation	Risk evaluation
Brain storm method and structural interview	√			√			√			√						√		
Delphi method	√			√			√			√						√		
Analytic Hierarchy Process (AHP)			√			√			√			√	√					√
Situation analysis	√	√		√	√		√	√		√	√		√	√		√	√	
Check list	√			√			√			√						√		
Preliminary hazard analysis	√		√															

(PHA)																		
Failure Modes and Effect Analysis (FMEA)				√	√		√	√		√	√		√					
Hazard and operability studies (HAZOP)				√	√		√	√		√	√							
Analysis and critical control point (HACCP)	√																	
Layer protection analysis method				√			√			√								
Structuring What-If Analysis (SWIFT)				√	√		√	√		√	√							
Risk matrix		√	√		√	√		√	√		√	√		√	√		√	√
Human reliability analysis						√		√			√							
Reliability Centered Maintenance	√	√											√		√			

Root reason analysis					√			√			√		√		√			
Sneak path analysis	√																	
Risk index						√			√			√			√			√
Failure tree analysis				√			√			√			√			√		
Event tree analysis				√	√		√	√		√	√		√	√		√	√	
Cause-effect analysis				√	√		√	√		√	√		√	√		√	√	
Decision tree analysis		√			√			√			√			√			√	
Bow-tie method		√			√			√			√			√			√	
FN curve					√			√			√							
Markov analysis method					√			√			√							
Monte Carlo Simulation method					√			√			√							
Bayesian analysis					√			√			√							

Appendix D

Instance for Injury Possibility Estimation

When one consumer strikes a nail into the wall with hammer, the chipping hits and hurts his eyes when the hammer collides with the nail. The occurring possibility of injury is estimated.

The steps are as follows:

Step 1: due to fragile material of the hammer head, it may crack when striking the nail. Experimental instrument can be used for testing its fragility degree in the service life. The results of the experiment show that the cracking possibility of hammer head is: 1/10.

Step 2: the chipping of hammer head hits the consumer. The occurring possibility of this case is estimated as 1/10 because the possibility for the upper part of the consumer's body of the consumer to touch drop-off chipping is about 1/10. The closer the consumer stays to the wall surface, the more possibly it will be hit by the chipping.

Step 3: the chipping of hammer hits the head of consumer. The head is 1/3 about the upper part of the human body, and the occurring possibility of such case is about 1/3.

Step 4: the chipping of hammer hits the eyes of consumer. Eyes are about 1/20 of the head in face of the drop-off chipping, and the occurring possibility of such step is about 1/20.

The possibilities of the above-said steps are multiplied together for deriving the injury possibility in this instance:: $1/10 \times 1/10 \times 1/3 \times 1/20 = 1/6000$.

Appendix E

Instance for Risk Grade Division of Consumer Product Hazard

The risk grades of consumer product hazard are divided as per the possibility and degree of the injury. Table F lists out the numerical value of injury possibility as reference for the risk grade division of consumer product hazard. The degree of the injury can be determined according to Table 1 in the Standard. The risk grade division of consumer product hazard is included in Table E.1.

Table E.1 Risk Grade Division of Consumer Product Hazard

Injury possibility		Serious degree of the injury			
		Very serious	Serious	Average	Weak
I	>50%	S	S	S	M
II	>1/10	S	S	S	L
III	>1/100	S	S	S	L
IV	>1/1000	S	S	M	A
V	>1/10000	S	M	L	A
VI	>1/100000	M	L	A	A
VII	>1/1000000	L	A	A	A
VIII	≤1/1000000	A	A	A	A

Graphic illustration

S	Serious risk
M	Moderate risk
L	Low risk
A	Tolerable risk

Appendix F

Risk Control Method for Life Cycle of Consumer Product Safety

The following methods can be taken for risk control of life cycle of consumer product safety:

F.1 Design Phase

——Select safe and reliable raw material. For example, replace the raw material that tends to cause injury event of consumer product with other safe raw material and power source;

——Reasonable model selection and arrangement of the equipment;

——Packaging material and mode of the product shall guarantee product safety and moreover, the minimum impact upon the environment, least waste and recovery design of packaging material shall be taken into account;

——Besides product safety, the storage, sale and transport mode of the product shall take into account environmental safety;

——Proper recovery channel and disposal method for waste product;

——Take safety protection measures;

——Others.

F.2 Production Phase

——Ensure the conformance of the product production to its design, and find out the nonconformance of the production process with the safety standards in the design via the sampling test of the product, and take remedy measures accordingly.

——Manual operation process in production shall conform to applicable regulations;

——Reasonable chemical substance added in the production;

——Others.

F.3 Packaging Phase

——Packaging material shall be safe and environment-protective, shall not generate any substance harmful to the health of consumers and shall be easy to recover for reuse;

——Packaging material shall ensure no injury to consumers in high-temperature, and humid and other extreme conditions;

——Safety precautions on the portage, storage, unpacking, use and maintenance of consumer product can be indicated on the packaging. Striking safety warning on potential hazard and reasonably foreseeable use shall be available. If necessary, operation manual and other information shall be attached;

——The size, dimension and shape of the packaging shall be reliable and safe, so as to guarantee both the quality of consumer product and the safety of consumers;

——The unpacking method of the packaging shall be convenient and safe, and shall especially take into account the special safety requirements of disadvantaged consumer groups such as the children, the old and the disabled;

——Others.

F.4 Storage and Transport Phase

——Proper storage and transport tool shall be selected according to the specification, quality, packaging form and load/unload mode of the consumer product;

——The storage and transport tool of consumer product shall be clean and safe, so as to ensure no pollution by harmful substance in the storage and transport of consumer product;

——Ambient factors in storage and transport such as temperature and humidity shall ensure the quality of consumer product and generate no substance harmful to consumers;

——Others.

F.5 Use Phase

——Establish a good information feedback, early warning and report system of injury event of consumer product;

——Perfect the user manual and relevant warning labels of consumer product;

——Carry out the education and training for consumers;

——Others.

F.6 Recovery Phase

——Consumer product and its packaging material shall be easy to recover for reuse;

——Conditional (such as depreciation price) recovery of waste consumer product, so as to encourage consumers to actively cooperate with the recovery activities;

——The recovered consumer product in conformity with the quality and safety requirements can be reused after treatment;

——Others.

References

- [1] GB/T 15706.1-2007 Mechanical Safety, Basic Concept and General Design Principles, Part I: Glossary and Method
- [2] GB/T 15706.2-2007 Mechanical Safety, Basic Concept and General Design Principles, Part II: Technical Principles
- [3] GB/T 20000.4-2003 Standardization Work Guide, Part IV: Safety-related Items in the Standard
- [4] GB/T 16856.1-2008 Mechanical Safety, Risk Evaluation, Part I: Principles
- [5] GB/T 16856.2-2008 Mechanical Safety, Risk Evaluation, Part II: Implementation Guide and Method Examples
- [6] GB/T 19001-2008 Quality Management System, Requirements
- [7] GB/T 20000.4-2003 Standardization Work Guide, Part IV: Safety-related Items in the Standard
- [8] GB/T 22696.1-2008 Electric Equipment Safety, Risk Assessment and Risk Reduction, Part I: General Rules
- [9] GB/T 22696.2-2008 Electric Equipment Safety, Risk Assessment and Risk Reduction, Part II: Risk Analysis and Risk Evaluation
- [10] GB/T 22696.3-2008 Electric Equipment Safety, Risk Assessment and Risk Reduction, Part III: Hazard, Hazardous Situation and Hazard Event Example
- [11] GB/T 24353-2009 Risk Management Principles and Implementing Guide
- [12] GB/T 25321-2010 Manufacturing Management Guide for Consumer Product Safety
- [13] YY/T 0316-2008/ISO 14971: 2007 Medical devices—Application of risk management to medical devices
- [14] ISO 14971 Medical devices—Application of risk management to medical devices
- [15] ISO/CD 10377 Consumer Product Safety: Practical Guidance for Suppliers, Committee Draft (V2)
- [16] Risk assessment guidelines for consumer products (Draft of 20 November 2007), http://ec.europa.eu/consumers/safety/committees/ra_guidelines_workshop11122007.pdf
- [17] Risk Assessment Guidelines for Non-food Consumer Products, <http://www.euchinawto.org>

II

(Non-legislative acts)

REGULATIONS

COMMISSION REGULATION (EU) No 1297/2014

of 5 December 2014

amending, for the purposes of its adaptation to technical and scientific progress, Regulation (EC) No 1272/2008 of the European Parliament and of the Council on classification, labelling and packaging of substances and mixtures

(Text with EEA relevance)

THE EUROPEAN COMMISSION,

Having regard to the Treaty on the Functioning of the European Union,

Having regard to Regulation (EC) No 1272/2008 of the European Parliament and of the Council of 16 December 2008 on classification, labelling and packaging of substances and mixtures, amending and repealing Directives 67/548/EEC and 1999/45/EC, and amending Regulation (EC) No 1907/2006 ⁽¹⁾, and in particular Article 53(1) thereof,

Whereas:

- (1) Regulation (EC) No 1272/2008 harmonises the criteria for the classification and the rules on labelling and packaging for hazardous substances and mixtures. It sets an obligation for suppliers to label and package substances and mixtures classified as hazardous in accordance with that Regulation before placing them on the market. It provides for rules to avoid accidental exposure and poisoning of consumers, in particular young children, to hazardous chemicals supplied to the general public.
- (2) Liquid consumer laundry detergents in soluble packaging for single use are placed on the market in the Member States, and the market share of this product is rising in the Union. The existing provisions for soluble packaging containing hazardous chemicals for single use do not provide sufficient protection. A uniform and more efficient approach to ensure better protection of the general public and especially young children and other vulnerable groups while maintaining free circulation of chemical products contained in soluble packaging is therefore warranted.
- (3) A significant number of severe incidents of poisoning and eye damage involving infants have been reported by Poison Centres in several Member States in regard to liquid consumer laundry detergents in soluble packaging for single use, with a higher accident rate compared to consumer laundry detergents in other packaging systems.
- (4) Although information campaigns in some Member States have shown some positive effects, it is necessary to lower the attractiveness to young children and to protect them by making this type of product less visible by using opaque outer packaging, by including an aversive agent (such as a bittering agent) in the soluble packaging to cause an immediate repulsive effect when in contact with the mouth and by rendering access to this type of product more difficult. Supplemental information should be included and highlighted on the label of the outer packaging of liquid consumer laundry detergents in soluble packaging for single use.
- (5) To rapidly address the severe consequences related to incidents with these products, while taking account of the necessary minimum time needed by economic operators to adapt to the new rules, an adequate transitional period should be provided.

⁽¹⁾ OJ L 353, 31.12.2008, p. 1.

- (6) Recourse to the urgency procedure under Article 54(4) of Regulation (EC) No 1272/2008 is warranted.
- (7) Without undue delay, further studies on relevant incidents will be carried out and further measures including the widening of the scope of the rules to other consumer products contained in soluble packaging and the review of the proposed rules will be considered.
- (8) The measures provided for in this Regulation are in accordance with the opinion of the Committee established under Article 133 of Regulation (EC) No 1907/2006 of the European Parliament and of the Council ⁽¹⁾,

HAS ADOPTED THIS REGULATION:

Article 1

Regulation (EC) No 1272/2008 is amended as follows:

- (1) in the second subparagraph of Article 35(2), the following sentence is added:

‘Where a liquid consumer laundry detergent, as defined in Article 2(1a) of Regulation (EC) No 648/2004 of the European Parliament and of the Council ^(*), is contained in a soluble packaging for single use, the additional requirements of section 3.3 of Annex II shall apply.

^(*) Regulation (EC) No 648/2004 of the European Parliament and of the Council of 31 March 2004 on detergents (OJ L 104, 8.4.2004, p. 1).;

- (2) Annex II is amended as set out in the Annex to this Regulation.

Article 2

1. By way of derogation from the second paragraph of Article 3, substances subject to Article 1, classified, labelled and packaged in accordance with Regulation (EC) No 1272/2008 and placed on the market before 1 June 2015 shall not be required to be relabelled and repackaged in accordance with Regulation (EC) No 1272/2008, as amended by this Regulation, until 31 December 2015.

2. By way of derogation from the second paragraph of Article 3, mixtures subject to Article 1, classified, labelled and packaged in accordance with Directive 1999/45/EC of the European Parliament and of the Council ⁽²⁾ or Regulation (EC) No 1272/2008 and placed on the market before 1 June 2015 shall not be required to be relabelled and repackaged in accordance with Regulation (EC) No 1272/2008, as amended by this Regulation, until 31 December 2015.

Article 3

This Regulation shall enter into force on the twentieth day following that of its publication in the *Official Journal of the European Union*.

It shall apply from 1 June 2015.

This Regulation shall be binding in its entirety and directly applicable in all Member States.

Done at Brussels, 5 December 2014.

For the Commission

The President

Jean-Claude JUNCKER

⁽¹⁾ Regulation (EC) No 1907/2006 of the European Parliament and of the Council of 18 December 2006 concerning the Registration, Evaluation, Authorisation and Restriction of Chemicals (REACH), establishing a European Chemicals Agency, amending Directive 1999/45/EC and repealing Council Regulation (EEC) No 793/93 and Commission Regulation (EC) No 1488/94 as well as Council Directive 76/769/EEC and Commission Directives 91/155/EEC, 93/67/EEC, 93/105/EC and 2000/21/EC (OJ L 396, 30.12.2006, p. 1).

⁽²⁾ Directive 1999/45/EC of the European Parliament and of the Council of 31 May 1999 concerning the approximation of the laws, regulations and administrative provisions of the Member States relating to the classification, packaging and labelling of dangerous preparations (OJ L 200, 30.7.1999, p. 1).

ANNEX

In Part 3 of Annex II to Regulation (EC) No 1272/2008 the following section 3.3 is added:

3.3 Liquid consumer laundry detergents in soluble packaging for single use

Where a liquid consumer laundry detergent in dosages for single use is contained in a soluble packaging, the following additional provisions shall apply:

- 3.3.1. Liquid consumer laundry detergents contained in soluble packaging for single use shall be contained in an outer packaging. The outer packaging shall fulfil the requirements of section 3.3.2 and the soluble packaging shall fulfil the requirements of section 3.3.3.
- 3.3.2. The outer packaging shall:
- (i) be opaque or obscure so that it impedes the visibility of the product or individual doses;
 - (ii) without prejudice to Article 32(3), bear the precautionary statement P102 “Keep out of reach of children” at a visible place and in a format that attracts attention;
 - (iii) be an easily reclosable, self-standing container;
 - (iv) without prejudice to the requirements of section 3.1, be fitted with a closure that:
 - (a) impedes the ability of young children to open the packaging by requiring coordinated action of both hands with a strength that makes it difficult for young children to open it;
 - (b) maintains its functionality under conditions of repeated opening and closing for the entire life span of the outer packaging.
- 3.3.3. The soluble packaging shall:
- (i) contain an aversive agent in a concentration which is safe, and which elicits oral repulsive behaviour within a maximum time of 6 seconds, in case of accidental oral exposure;
 - (ii) retain its liquid content for at least 30 seconds when the soluble packaging is placed in water at 20 °C;
 - (iii) resist mechanical compressive strength of at least 300 N under standard test conditions.’
-

Checklist for key persons reporting

Section 1)

Please add a summary of information on the;

- background
- main consumer concerns/issues in the area
- key consumer objective, the aim of consumer participation
- then subsequently write if the key consumer objectives are reached or not.
(Example: The key consumer objective is to include requirement on surface temperatures. This is now included in the standard).

The target audience for this is: public interest groups, consumer organizations, COPOLCO members, NSBs, mirror committees, and all related stakeholder groups.

Section 2)

Please inform on the relevant consumer standards and committees leading this work: committee number and title (TC, SC, PC and WG when relevant), standard affected (show the standard or working draft/NWIP number and title), and a brief description of progress and/or issues addressed during this reporting year (note any key dates for action eg voting periods or advancement in stage eg CD to DIS).

If there is no change in status or involvement for a given standard, do not add any information.

Please use one table row per standard (add cells to the table as necessary).

Section 3)

Please add relevant hyperlinks to articles, committee pages, national standards body and other.

If possible, please limit your comments to approximately 1/2 of a A4 page.

Section 4)

Please tell us when the latest information dates from (eg the dates of the last meeting of your working group or technical committee) in yyyy-mm-dd format, and when the next meetings will take place : yyyy-mm-dd (or is proposed eg in 18 months, date tbc). It is also useful to know the name of a consumer representative (if different to the key person) and any other consumer organizations/representatives present.

Note: COPOLCO has defined the term consumer to mean “an individual member of the general public, purchasing or using goods, property or services, for private purposes”. A consumer representative is someone who can represent consumers' perspectives; such as a designated representative of a consumer organization.

Key Persons Reporting Form

Key area: ISO/TC 261 Additive manufacturing

1. Summary

Additive Manufacturing is used to manufacture prototypes, tools and production parts. In comparison to conventional methods where parts are molded into specified forms or cut from a massive block, Additive Manufacturing bases on the principle that liquids, powders, stands and films are layered to build 3D-structures without the use of a mold. It refers to the process of joining materials to manufactured objects, usually layer upon layer, as opposed to “subtractive manufacturing” methods, such as machining. 3D Printing is a synonym often used for Additive Manufacturing and summarizes various technologies and ways of using this technology.

Figure 1. Hype Cycle for 3D Printing, 2014

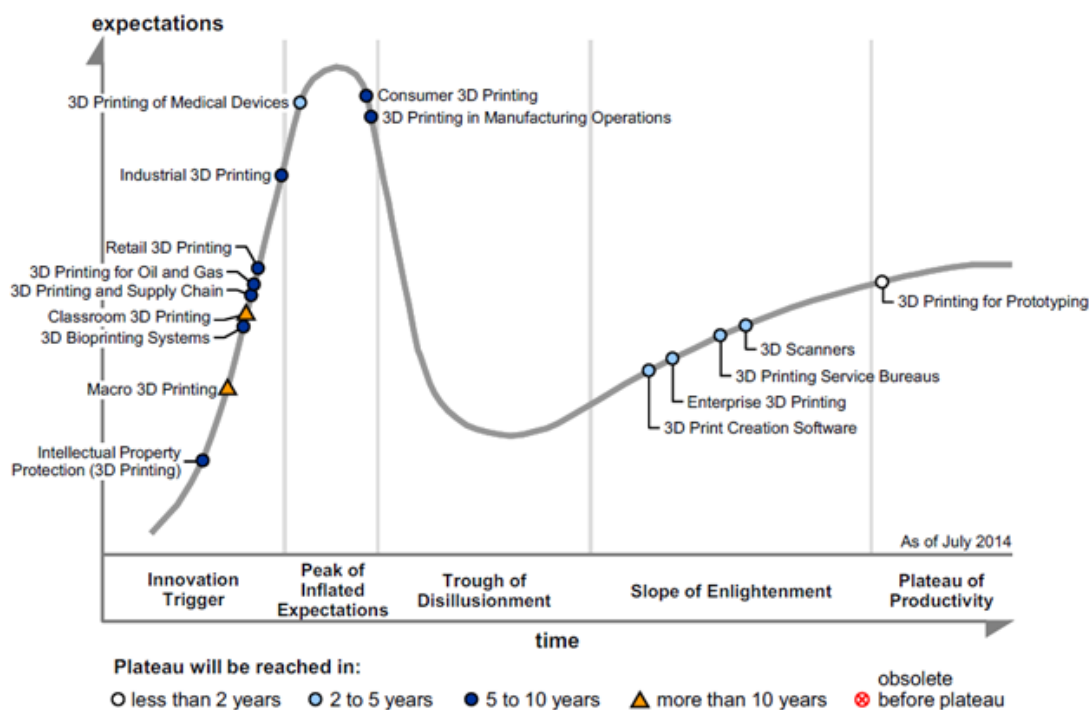

Source: Gartner 2014

ISO and ASTM International signed a Partner Standards Development Organization (PSDO) cooperation agreement in 2011 to increase their cooperation in the development of International Standards for additive manufacturing. The decision to set up the PSDO agreement followed the creation of ISO technical committee ISO/TC 261, Additive manufacturing. ASTM's committee F42, Additive manufacturing technology, already had important work in this area and it was decided that both groups would benefit from combining their expertise. Internal liaisons have been initiated with ISO/TC 61, ISO/TC 61/SC 9, ISO/TC 106, ISO/TC 106/SC 9, ISO/TC 119, ISO/TC 184, ISO/TC 213 and IEC/TC 76.

The main objectives of ISO/TC 261 are to standardize the processes of Additive Manufacturing, their process chains (Hard- and Software), test procedures, quality parameters, supply agreements, fundamentals and vocabularies. It is agreed by all member bodies that those objectives always have to follow the market needs and enable flexible reaction on changes.

Structure of AM Standards

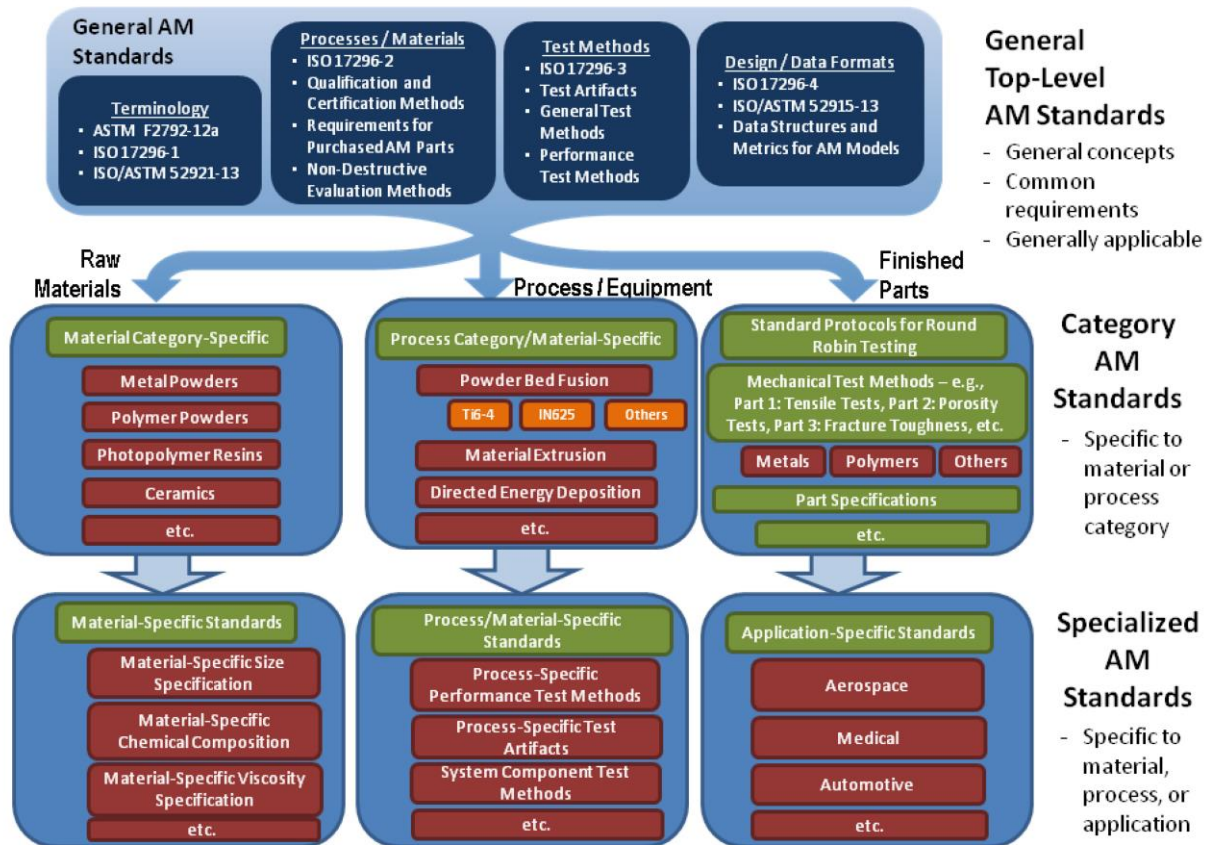

Taken from ISO/TC 261 Business Plan 06/08/2015

The main consumer issues in this area relates to consumer product safety for products that may be manufactured using 3D printing technology. Before the standards development work becomes advanced in this area, now would be a good timing to raise consumer safety concerns to the ISO/TC 261 committee. The key consumer objective is to include these consumer safety requirements in the current projects; this objective is pending.

Please note that there will be a distinction between:

- Current TC 261 work – keep in Key Areas WG (this template)
 - The 3D printing design community will need to take the initiative in ensuring consumer safety is integral to product design.
- New items for consumers in the Product Safety WG (different template)
 - COPOLCO could seek to include:
 - safety of raw materials, 3D printer use and product outputs within ISO/TC 261's scope or propose a separate project.
 - Develop and adapt product safety education and guidance materials suitable for 3D print designers and producers.
 - Recommendation that the 3D printing design community should establish forums for conferring and collaborating with one another and other product practitioners on safe design.

2. Standards work

Technical Committee/ Title/ WG	Working draft or standard (number and title)	Progress or change during reporting year Any action to be taken
ISO/TC 261	ISO 17296-2:2015 Additive manufacturing -- General principles -- Part 2: Overview of process categories and feedstock	60.60 Published Standard
ISO/TC 261	ISO 17296-3:2014 Additive manufacturing -- General principles -- Part 3: Main characteristics and corresponding test methods	60.60 Published Standard
ISO/TC 261	ISO 17296-4:2014 Additive manufacturing -- General principles -- Part 4: Overview of data processing	60.60 Published Standard
ISO/TC 261	ISO/ASTM 52900:2015 Additive manufacturing -- General principles -- Terminology	60.60 Published Standard
ISO/TC 261	ISO/ASTM 52915:2016 Specification for Additive Manufacturing File Format (AMF) Version 1.2	60.60 Published Standard
ISO/TC 261	ISO/ASTM 52921:2013 Standard terminology for additive manufacturing -- Coordinate systems and test methodologies	60.60 Published Standard
ISO/TC 261	ISO/ASTM DIS 52901 Additive manufacturing -- General principles -- Requirements for purchased AM parts	40.60 DIS - Close of voting
ISO/TC 261	ISO/ASTM NP 52902 Additive manufacturing -- General principles -- Standard test artifacts	10.99 Proposal stage - New project approved
ISO/TC 261	ISO/ASTM DIS 52903-1 Additive Manufacturing -- Standard Specification for Material Extrusion Based Additive Manufacturing of Plastic Materials -- Part 1: Feedstock materials	40.20 DIS ballot initiated: 3 months

Technical Committee/ Title/ WG	Working draft or standard (number and title)	Progress or change during reporting year Any action to be taken
ISO/TC 261	ISO/ASTM CD 52903-2 Additive manufacturing -- Standard specification for material extrusion based additive manufacturing of plastic materials -- Part 2: Process -- Equipment	30.99 CD approved for registration as DIS
ISO/TC 261	ISO/ASTM DIS 52910 Standard Practice -- Guide for Design for Additive Manufacturing	40.99 Full report circulated: DIS approved for registration as FDIS

3. Relevant links

The committee website is located at:

http://www.iso.org/iso/home/standards_development/list_of_iso_technical_committees/iso_technical_committee.htm?commid=629086

Committee liaisons to ISO/TC 261:

- ISO committees in liaison include ISO/TC 44, ISO/TC 44/SC 14, ISO/TC 119, ISO/TC 150, ISO/TC 184/SC 1, ISO/TC 184/SC 4
- IEC committees in liaison include IEC/TC 76 Optical radiation safety and laser equipment

Committee liaisons from ISO/TC 261:

- ISO committees in liaison include ISO/TC 44, ISO/TC 61, ISO/TC 61/SC 9, ISO/TC 106, ISO/TC 106/SC 9, ISO/TC 119, ISO/TC 184, ISO/TC 213
- IEC committees in liaison include IEC/TC 76 Optical radiation safety and laser equipment

http://www.iso.org/iso/home/standards_development/list_of_iso_technical_committees/iso_technical_committee.htm?commid=629086

ISO Article on work of ISO/TC 261: <http://www.iso.org/iso/news.htm?refid=Ref1956>

4. Information of meetings and consumer participation

Committee No./Title	Date of last meeting (yyyy/mm)	Date of next meeting (yyyy/mm/dd)	WG/ Standard(s)	Consumer representative(s) (Name, organisation/ affiliation) involved in the key area
ISO/TC 261	unknown	14 July 2016 in Tokyo	Current program listed above	n/a

A Joint ISO/ASTM Steering Group has been established to monitor the progress of the joint groups, report on the status of the joint groups, resolve any problems, present proposals for joint activities to the respective plenary groups, and maintain a three-year plan for joint standards development. The Joint Steering Group conducts virtual meetings twice per year (in spring and autumn – northern hemisphere) to be scheduled between the fixed ISO/TC 261 and ASTM F42 plenary meetings. The group may also take the opportunity to meet face-to-face at meetings of ISO/TC 261 or ASTM F42.

5. Key person

a) Are there changes to your contact details? Yes No
 If yes, please complete the table below:

Name:	<i>Alison Scotland</i>	Tel:	+612 9237 6088
Position:	<i>National Sector Manager</i>	Fax:	
Organization:	<i>Standards Australia</i>	E-mail:	Alison.scotland@standards.org.au
Address:	<i>Level 10, 20 Bridge Street, Sydney NSW 2000 AUSTRALIA</i>		

*Please return the form by e-mail to copolco@iso.org by **19 March 2016***



International Organization for Standardization
 Organisation internationale de normalisation
 Международная организация по стандартизации

Ch. de Blandonnet 8 | CP 401, 1214 Vernier | Geneva, Switzerland | T: +41 22 749 01 11 | central@iso.org | www.iso.org

ISO/COPOLCO N 193

Ref. COPOLCO N193 /2016

TO THE COPOLCO MEMBERS

Date 2016-02-10

Product safety issues and information

Dear Members,

We would appreciate your attention to one action item and some additional information:

Safety of ride-on toys

Please find attached a communication from the COPOLCO member of SII (Israel) concerning a safety standard for electric toys which is under development in IEC. IEC-62115 will be sent out for CDV (Committee Draft for Vote) on 12 February.

We bring this to the particular attention of members whose National Standards Bodies are also members of IEC, to coordinate input into a national position on the vote. Furthermore, the convenors of the COPOLCO product safety working group would appreciate receiving accident data or related information about incidents with ride-on toys (send it to copolco@iso.org).

Educational video and leaflet on toy safety

ANEC (the European consumer voice in standards) has endorsed an educational video on toy safety. This was produced by the Toy Industries of Europe (TIE), and ANEC wishes to share this information with COPOLCO members. The video shows twelve simple tips to help children play safely with toys.

Please feel free to share this [video](#), which is available in different languages, to pass on these tips as good advice to keep children safe during play. We are also enclosing an accompanying leaflet (see <http://www.tietoy.org/toy-safety/toy-safety-tips/>).

Guidance on unit pricing – update and videos

ISO/PC 294, “Guidance on unit pricing”; held its first meeting in November 2015 in Sydney, Australia, and has developed a working draft of the future ISO 21041. A dedicated working group will meet on 19-21 April in Singapore to continue this work.

Please contact the ISO Technical Programme Manager, Mr Stefan Marinkovic or the Committee Secretary, Mr Steven Cooke through your ISO member channel for more information about this project committee, and participation. See contact details and other information [here](#).

In the meantime, the Malaysian Association of Standards Users (DSM) has kindly provided some videos about unit pricing and permission to disseminate the information widely. They are: "[How unit pricing can help you](#)" and "[People's view on unit pricing](#)". See:

- How can unit pricing help you: <https://www.youtube.com/watch?v=k1BnDeguwAM>
- People's view on unit pricing: <https://www.youtube.com/watch?v=UdRUBPYfytl>

We thank you for your attention to the above,

Dana Kissinger-Matray
 Secretary of ISO/COPOLCO

Enclosures

Request to support the safety standard for electric toys, IEC-62115 / EN-62115 - 2nd edition

One more step to go.

Thanks to the continuous support by COPOLCO, ANEC and CI, the new safety standard for electric toys, 2nd edition of IEC-62115 / EN-62115, has finally reached stage CDV (Committee Draft for Voting), and will soon be submitted to National Standards Committees for voting. Voting will start on February 12th.

As you remember, we have successfully supported annex J, related to safety of remote controls for electrical ride-on toys, to prevent identified safety hazards.

In addition, several other major topics are covered in the new 2nd edition, which will replace the previous 1st edition published in 2003 including its two amendments (2004, 2011).

Since IEC-62115 / EN-62115 - 2nd edition can prevent severe injuries, and even save lives of children, we would kindly ask you to encourage National Standards Committees to strongly support it.

Several potential hazards to children have been identified, relating to technologies that became common in electric toys during the last decade.

Following are examples for those potential hazards:

1. New types of batteries impose new safety hazards. For example, Lithium-ion batteries contain a flammable electrolyte and are also kept pressurized.

To prevent the risk for injury and death, the new standard sets requirements to assure safe use of batteries in electric toys.

2. Use of LEDs (Light Emitting Diodes) in toys became very popular, and dangerous. Children playing with those toys can suffer permanent eye damage, since currently there is no limitation whatsoever on intensity and wavelength of light emitted by LED toys.

To protect children's eyes, **Annex E** of the new standard sets safety limits on intensity and wavelength of LEDs.

3. Parental remote controls for electrical ride-on toys impose significant safety hazards. Children's lives can be lost when parents lose control unexpectedly. Fatal accidents can happen when:
 - * The child drives out of remote-control reception range, or,
 - * When one remote-control drives a different ride-on toy unintentionally, or,
 - * When the child himself can switch the car to un-controlled driving mode.

To prevent children's injuries and deaths, **Annex J** of the new standard adds the following requirements, in case that a parental remote-control is used with a child-driven electrical ride-on toy:

a. Ride-on-toy shall stop automatically upon losing wireless communication between the transmitter and the receiver, e.g., while leaving the reception range, or due to a weak battery.
This requirement is essential to prevent parent's losing of control unexpectedly.

b. It shall not be possible to control or affect driving of one ride-on-toy by using a remote-control of another ride-on-toy.
This requirement is essential to prevent one ride-on toy be driven unintentionally and unexpectedly by a remote-control of another ride-on toy.

c. Switching from "controlled" driving mode to "un-controlled" driving mode shall not be possible without the aid of a tool.
This requirement is essential to prevent the child from switching the ride-on-toy to "un-controlled" mode, causing the parent to lose control unexpectedly.

Please encourage your National Committee to support IEC-62115 and EN-62115 2nd edition. Your help and cooperation will prevent further delays in the implementation of this essential safety standard.

Brought to you by



Supported by



For more information on toy safety visit www.tietoy.org

SAFETY FIRST

TOP TIPS TO ENJOY TOYS



Children learn through play, and toys make an essential contribution to their development.

To ensure children have the best play experience, keep in mind the following Toy Safety Tips.

Buy toys from trustworthy retailers

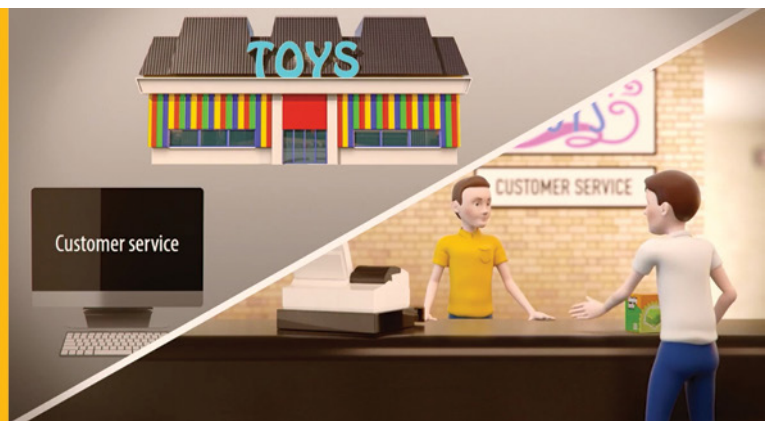

Beware of counterfeit toys

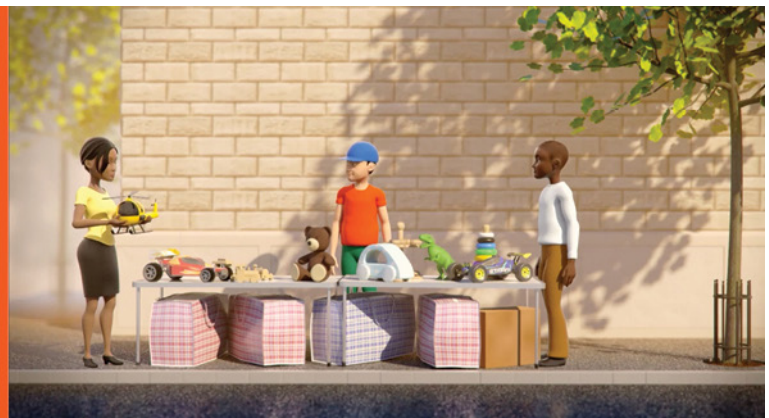

Always check toys carefully

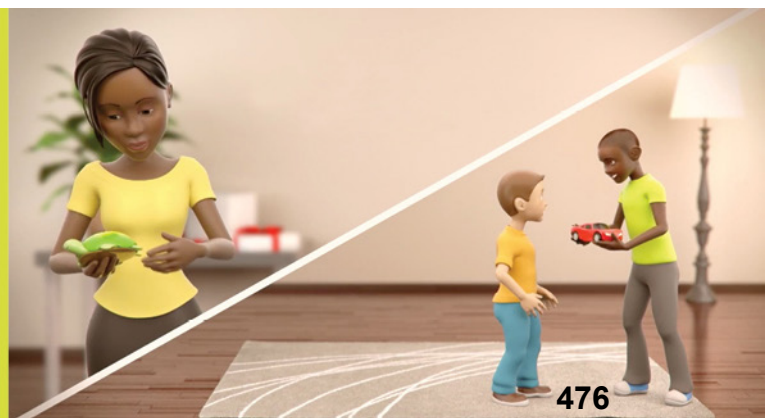

**Read
all
warnings**



**Check
the age
recommendation**



**Remove
all
packaging**



**Follow
the
instructions**



**Keep an eye
on children as
they play**



Wear appropriate safety gear



Keep damaged toys away from children



Don't leave toys lying around



Report any problems

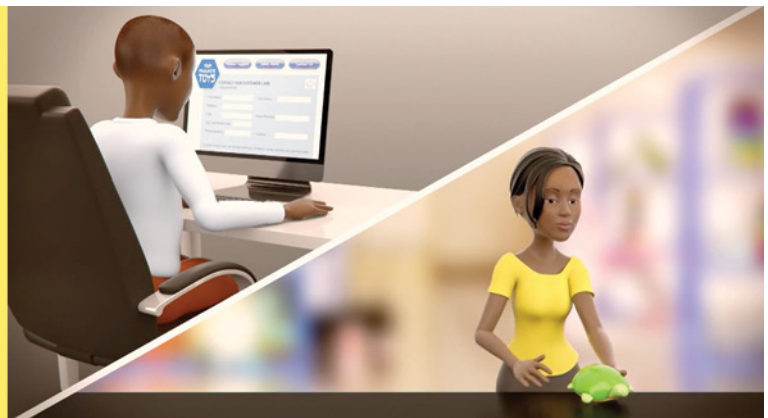

Table) Progress on PS WG projects and issues in 2015

#	issues	Standards or TCs affected/involved	progress			Notes	Results of discussion on 4 th Nov. at CG meeting
			Preliminary stage	Template stage	NWIP/ communication		
1	<p>safety issues regarding the inadequacy of instructions for assembly and maintenance for self-assembly products</p> <p><i>incorrect translation, misleading or contradictory information can result in incorrect or unsafe assembly</i></p> <p><i>not addressed in ISO/IEC 82079-1</i></p>	<p>IEC 82079-1: 2012 Preparation of instructions for use - Structuring, content and presentation - Part 1: General principles and detailed requirements</p> <p>IEC/TC3 Information structures and elements, identification and marking principles, documentation and graphical symbols</p> <p>ISO/IEC TC 3 JWG 16 for revision</p>			<p>ISO/IEC 82079-2 Part 2. Provisions for instructions for self-assembly products submitted to IEC TC 3</p> <p>Rejected by IEC TC 3 due to lack of nominated experts</p>	<p>ISO/IEC TC 3 JWG 16 convener Ms. Gabriela Fleischer (revising IEC 89079-1)</p>	<p>DIN (Karin Both) will approach ISO/IEC TC 3 JWG 16 convener for further follow up.</p>

2	<p>Choking hazards of small component parts of products</p> <p><i>Small parts can be accidentally inhaled and cause a potential choking hazard</i></p>	<p>TC 122 (packaging)</p> <p>ISO/IEC Guide 41</p> <p>Packaging -- Recommendations for addressing consumer needs</p>			<p>Submitted to TC 122 and responded it's not in the scope of the committee</p> <p>Forwarded to COPOLCO WG 16 (Guide 41 revision committee)</p>		<p>a. Members of PS group to send evidence to co-chair and secretariat.</p> <p>b. BSI (Christine Heemskerk) volunteered to be the project champion</p>
3	<p>Risk management</p> <p><i>Guide 51, ISO 31000 and the Safety less feasible in implementation, providing the method of calculating safety risk evaluation for consumer products</i></p>	<p>ISO 31000:2009 Risk management - Principles and guidelines</p> <p>IEC 31010:2009 Risk management - Risk assessment techniques</p> <p>ISO 10377:2013 Consumer product safety - Guidelines for</p>	<p>Form a sub-committee (or a task group) to redraft template for further consideration of members</p>			<p>Tentative title: General Principles for Risk Management of Consumer Product Safety</p>	<p>SAC (Lili Cao) to liaise with Chinese experts to re-draft the originally submitted template and submit it to the group for review.</p>

		suppliers					
4	E-cigarettes <i>very high risks of the chargers (many domestic fires caused by faulty chargers)</i>	ISO/TC 126 Tobacco and tobacco products				EU/ISO level actions. AFNOR proposal to create a new ISO committee. Discussions on ISO level regarding allocation of the proposal (new committee or SC under ISO / TC 126)	watching brief
5	Nappy Sack <i>Problem of suffocation</i>				Forwarded to COPOLCO WG 16 (Guide 41 revision committee)		topic was passed to COPOLCO WG 16 (the Guide 41 Group).
6	Liquitabs/washing pods <i>Severe burns and death caused due to mouthing/ swallowing liquitabs</i>	ASTM F15.71 is developing a standard to address the safety of liquid laundry packets					a. Circulate the issue to the members to find out if anyone wants to do more.

	<i>(dishwasher/washing machine detergent capsules).</i>						b. Contact ISO TC 91 to see if it covers liquid-tabs/liquid-pods and addresses safety issues
7	3D or additive printing <i>product safety issues and concerns that need to be monitored</i>	ISO TC 261 (Additive manufacturing) ISO/IEC JTC 1 informational technology	contact ISO TC 261 to raise safety concern			be outside of the jurisdiction of the PS WG and probably would be best considered by the Global	SA (John Furbank) to develop an activity template
8	Drones <i>Consumerization of drones</i>	ISO TC 20/SC16 (Aircraft and space vehicles)	contact ISO TC 20/SC16 to raise safety concern			Marketplace Group	refer issue to the global marketplace WG
9	Vertical axis top loading washing machines	IEC TC 61 Safety of household and similar electrical appliances IEC 60335-2-7-A2/Ed7: Household and similar				Standard contains requirements for appliances with front opening doors, but not	members and consumer representatives to raise the issue for national delegations to IEC

		electrical appliances - Safety - Part 2-7: Particular requirements for washing machines				for vertical axis top loaders	TC 61
10	Lowering of external surface temperatures of household products	IEC 60335 standards: Household and similar electrical appliances - Safety				IEC TC 61 approved lower Surface Temperature Limits for tumble dryers and vacuum cleaners. Work on other appliances is still ongoing	watching brief



International Organization for Standardization
Organisation internationale de normalisation
Международная организация по стандартизации

AGENDA ITEM 14 CONSUMER PARTICIPATION AND TRAINING WORKING GROUP

AGENDA ITEM 14 REPORT FROM THE COPOLCO CONSUMER PARTICIPATION & TRAINING WORKING GROUP

1 Working Group structure and terms of reference

The group is co-chaired by Sadie Homer, CI and Guillermo Zucal, IRAM.

The principal ongoing activities relate to funding, training and updating the ISO Directory of consumer interest participation. The ISO Strategic Plan 2016-2020 and the ISO Action Plan for Developing Countries will form a basis for an action plan for the working group.

The Consumer Participation & Training Working Group (CP&T WG) Terms of Reference were confirmed at the 2014 Plenary (Resolution 7/2014).

2. Funding consumer participation

Many NSB's and consumer groups are struggling to either maintain or find sufficient funding to be able to provide consumer participation into national standards work; there are additional resource requirements for regional and international work.

Guillermo Zucal (IRAM) and Rémi Reuss (AFNOR) lead the Funding Task Group.

The soon-to-be-launched ISO Directory of consumer interest participation will provide a new section "Country case study in consumer participation". This will give the opportunity for countries to share platforms and projects where funding and activities have been successfully implemented and the donors/supporters who have made this possible. As this was a primary aim of the task group and it has been achieved, the CP&T may wish to consider the role and future of the FTG. The continuing challenge to find sustainable resources to support consumer representation may need a fresh and focused alternative approach.

Two factors that should be considered are the recent MoU between the World Bank and ISO, as well as consideration of new innovative forms of fundraising. Both may present new opportunities to COPOLCO members that can be discussed in the WG meeting. Remi Reuss will present a verbal report on an innovative approach being launched by AFNOR to support consumer advocacy at the plenary.

3. ISO Action Plan for developing countries 2016-2020

This was published earlier in 2016 and outlines the framework under which ISO will provide technical assistance to developing countries. It lays out the expected outputs and how they will be achieved. It also cites the programmes that will complement these activities, including:

- The ISO sponsorship programme supporting participation in the work of technical committees: ISO members from developing countries are entitled to three sponsorships per calendar year to attend technical committee meetings of their choice, funded by ISO.
- New initiatives (based on research and consultation with ISO members and partners) aimed at launching new standards projects of particular interest to developing countries
- IT platforms and tools to support the sharing of information and decision making among ISO members.

4. Balanced representation on TC/WGs

The information that is being collected on stakeholder representation in standards development will be an important tool, not only track where vital consumer representation is needed but to increase confidence in the credibility and accountability of the ISO process. An example of a requested stakeholder composition report is attached at Annex 1.

However it is difficult to determine accurate data on the current participation of consumer representatives in national technical and policy committees of NSB's, as well as in mirror committees of those at international level, such as ICO COPOLCO. Some information is also available from the ISO Consumer Directory. However it is still hard to determine an accurate and up to date 'real time' picture that is important in standards of key interest to consumers.

The CP&T may consider how this information could be gathered and the potential benefits of doing so.

5. ISO Directory of consumer interest participation

Dana Kissinger and her team lead this activity.

The ISO Directory of consumer interest participation has been developed and is in the final test phases. Every member will be able to input this data via an online form, and various types of outputs will be developed progressively based on it, including information on the ISO website. An update will be given at the Plenary.

This will enable countries to add case studies of national consumer participation that can be used as case studies of good practice.

6. Collaboration within regional groups

A list of regional groups was compiled and circulated for a final update. The document can be found at Annex 2. Please advise if there any errors or omissions.

7. Best practices Guidance document for succession planning

Nicki Islic, CSA (SCC) has co-ordinated a group to prepare a short paper on succession planning. As the cohort of experienced consumer representatives grows older, this is an opportunity to share experiences on ways of attracting younger consumer representatives to be trained. Its objective is to develop a best practices guidance document to share information and assist NSBs in succession planning activities.

This succession planning document is being prepared for review and comment at the up-coming COPOLCO meeting. The final document will be circulated to all COPOLCO members to share with their respective organizations before the meeting. Thank you to Australia, Canada, and Norway for their contributions. The Task Force encourages additional member bodies to submit their best practices and guidance on succession planning related to standards development activities, so that they can be added to the guidance document.

8. Evaluation of Distance learning Module

The COPOLCO Secretariat is compiling the 2015-16 figures on use of the Distance learning module and these will be circulated to the WG as soon as they are available. The CP&T group may then wish to discuss its future promotion.

9. Regional/national training workshops

Three major training events took place in 2015 jointly run by ISO Academy and ISO/COPOLCO, with the COPOLCO Consumer participation and training group taking the lead coordination and implementation role.

The first one was in Geneva in May 2015, directly preceding the COPOLCO plenary meeting with support for trainees to stay for the COPOLCO working group meetings and Plenary. The consumer participation and training group reported on this at the 2015 Plenary.

The second one took place in Addis Ababa, Ethiopia at the invitation of the African Organization for Standardization (ARSO) and the Ethiopian Standards Association (ESA), in August 2015. It was the

first time that an awareness-raising workshop on consumer matters for delegates to ARSO's annual General Assembly was held. Sadie Homer, David Bell (BSI) and Dana Kissinger-Matray provided the international perspective, and experts from the Ethiopian Standards Association presented national case examples of consumer participation in ESA's work. A summary report of that highly successful event appears at Annex 3.

Finally, the ISO Academy and ISO COPOLCO hosted a side event at the Consumers International World Congress in Brasilia, Brazil in November 2015. Kevin McKinley and Dana Kissinger-Matray attended from ISO and Sadie Homer, CI along with consumer experts from around the world, contributed to this event.

Connecting with consumers – empowerment through standards was an interactive training day supported by the ISO Academy (including 26 sponsored participants) which highlighted different models of consumer participation as well as discussion of specific case studies of standards on e.g. second-hand goods, clean cook stoves, and water delivery services. Many other congress attendees joined the sponsored participants for the outreach session which was opened by CI's Director General.

All of those participants that responded said that they felt the day would be useful to their current work and that it would help them in their future work in standardisation. A full report is available on request.

Within the main congress, CI held an open session **Standards today – legislation tomorrow** which featured five panelists including an interview and Q&A with Kevin McKinley who debated the question, "Are standards beneficial to consumers?" Panelists described cases of standards used to support legislation, with examples of gas cylinders, accessibility, and water services. Questions were raised on the inclusivity of the standards building process and adaptability of ISO's processes. Mr McKinley stressed ISO's efforts to put high priority on stakeholder engagement in its new strategy.

Both events met their objectives of bringing the role standards play in the consumer protection tool kit, to the centre of the consumer movement, as well as bringing NSB's greater understanding of consumer issues and the importance of engaging them in standards development.

The CP&T will consider how it can best collaborate with the ISO Academy and DEVCO in implementing the Action Plan for Developing Countries. The ISO Academy will support an East Europe/Central Asia consumer training event either in Vienna or Prague this coming September or October 2016.

Draft Resolutions

COPOLCO Resolution x/2016

Consumer participation and training group (1) – ISO Directory of consumer interest participation

COPOLCO

notes the forthcoming launch of the revised and updated ISO Directory of consumer interest participation, including a new form on participation,

thanks the ISO COPOLCO secretariat and team for completing this task,

encourages all ISO COPOLCO members to complete the online form with detailed information to provide accurate and updated data to support COPOLCO's work,

Invites all ISO COPOLCO members to make use of this valuable resource.

COPOLCO Resolution x/2016*Consumer participation and training group (2)*

notes the outstanding success of the joint ISO and CI training, outreach and associated standards events at Consumers International's 20th World Congress,

thanks the Swedish International Development Cooperation Agency (SIDA), the ISO Secretary General and ISO staff for their support in delivering the event,

highlights the ongoing importance of collaboration with the consumer movement and with consumer stakeholders to build credible ISO standards.

Annexes:

Annex 1 – Sample report on consumer stakeholder participation in a WG

Annex 2 – List of regional organizations

Annex 3 – Summary report of the ARSO consumer training event.



**DRAFT AGENDA – COPOLCO Consumer Participation & Training Working
Group meeting – 16 June 2016 – Mövenpick Hotel, Geneva, Switzerland
10:30 – 12:00 am**

Item		Document	Rapporteur
0.	CP & T Working Group Report	N213/2016 and annexes	
1.	Introductory remarks		Guillermo Zucal Sadie Homer
2.	Funding Task Group (Work Plan Action 2) - Update on activity Discussion on the role and future of the group		Guillermo Zucal Rémi Reuss
3.	Consumer representation on TCs and WGs (WP 3 and 4) - Discussion on uptake		
4.	ISO Directory & data collection template (WP 5) - Update on IT Services project and progress Actions for members		Dana Kissinger
5.	Regional Consumer Engagement Strategies (WP 6) - Updates from regions		
6.	COPOLCO Mirror committee guidance (WP 9) – <i>ISO CS feedback</i> - Any feedback from NSBs		

Item		Document	Rapporteur
7.	Succession Planning (WP 10) - Update on progress - Feedback on draft report		Nicki Islic (CSA) Suzanna Ersoy (SCC)
8.	Training (WP 11 and 12) - Review of training event held pre ISO COPOLCO 2015 - Review of regional training held in Ethiopia in August 2015 - Review of ISO academy training event at CI World congress - Discussion to cover future possibilities		Sadie Homer Dana Kissinger
9.	Progress on other items in CP Work plan including: - Support ISO Strategic plan 2016 - 2020 (WP 1) – <i>ISO CS</i> - Collaboration with Regional Groups (WP 7) – <i>regional group reps present</i>		
10.	Any other business from WGs		
11.	Concluding remarks – actions summary - Draft Resolutions		



Example of a search of consumer stakeholders in a technical committee

Committee Reference	Role	Appointed By	Stakeholder Category	Last name	First name	Person's Personal Email
ISO/TC 290/WG 1	Committee member	SCC	C - Consumers	Harkness	Patrick	pharknes@telus.net
ISO/TC 290/WG 1	Liaison representative (organizations)	ANEC	C - Consumers	Hunter	Julie	juliehunter@hotmail.co.uk
ISO/TC 290/WG 1	Committee member	SCC	C - Consumers	Islic	Nicki	nicki.islic@csa.ca
ISO/TC 290/WG 1	Committee member	SCC	C - Consumers	Kumar	Sasi	eskumar@live.com
ISO/TC 290/WG 1	Committee member	DIN	C - Consumers	Scheiber	Anke	a.scheiber@stiftung-warentest.de
ISO/TC 290/WG 1	Committee member	DIN	C - Consumers	Tang	Natalie	natalie.tang@din.de
ISO/TC 290/WG 1	Liaison representative (organizations)	ANEC	C - Consumers	Vuerich	Michela	michela.vuerich@anec.eu
ISO/TC 290/WG 1	Committee member	SCC	C - Consumers	Webb	Kernaghan	kernaghan.webb@ryerson.ca



REGIONAL ORGANIZATIONS DEALING WITH CONSUMERS AND STANDARDS

ARSO COCO – African Organization for Standardization (Consumer Committee).

35 members: Benin, Burkina Faso, Botswana, Cameroon, Congo Brazzaville, Cote d'Ivoire, Democratic Republic of Congo, Egypt, Ethiopia, Gabon, Ghana, Guinea, Guinea Bissau, Kenya, Liberia, Madagascar, Malawi, Mauritius, Namibia, Niger, Nigeria, Rwanda, Senegal, Seychelles, Sierra Leone, South Africa, Sudan, State of Libya, Swaziland, Tanzania, Togo, Tunisia, Uganda, Zambia, Zimbabwe.

Promotes Consumer participation in African standardization processes as a means of availing them an avenue to articulate consumer interests in the standardization and conformity assessment. ARSO- COCO aims at protecting and giving a platform to consumers and thus ensuring quality and standard goods and services. Its objectives:

- a) Provide a forum for the exchange of information and experience on standards
- b) Providing information on how standardization benefits consumers and how consumers can contribute to standards development
- c) Mobilize African consumer bodies to participate in National and Regional standards setting
- d) Provide standardization informational materials on consumer issues
- e) Ensure the African standards produced are relevant to the market
- f) Ensure a standardization process that protects the consumers' health and safety.

Contact: Hermogene Nsengimana
ARSO Central Secretariat
International House 3rd Floor.
P. O. Box 57363 -00200 City Square, Nairobi, Kenya.
Tel. +254-20-2224561, +254-20-3311641, +254-20-3311608
E-mail: arso@arso-oran.org, info@arso-oran.org

ACCSQ - Association of Southeast Asian Nations, or ASEAN

10 members: Brunei Darussalam, Cambodia, Indonesia, Lao PDR, Malaysia, Myanmar, Philippines, Singapore, Thailand, Viet Nam

The ASEAN Socio-Cultural Community (ASCC) aims to contribute to realizing an ASEAN Community that is people-oriented and socially responsible with a view to achieving enduring solidarity and unity among the peoples and Member States of ASEAN. It seeks to forge a common identity and build a caring and sharing society which is inclusive and where the well-being, livelihood, and welfare of the peoples are enhanced. ASCC is focused on nurturing the human, cultural and natural resources for sustained development in a harmonious and people-oriented ASEAN.

The ASCC Blueprint represents the human dimension of ASEAN cooperation and upholds ASEAN commitment to address the region's aspiration to lift the quality of life of its peoples. The goals of the ASCC are envisaged to be achieved by implementing concrete and productive actions that are people-centred and socially responsible. This set of cooperative activities has been developed based on the assumption that the three pillars of the ASEAN Community are interdependent and interrelated and that linkages are imperative to ensure complementarity and unity of purpose

Contact: Public Outreach and Civil Society Division, ASEAN Secretariat, Jakarta
E- mail: public.div@asean.org

AIDMO – Arab Industrial Development and Mining Organization

21 members - Jordan, United Arab Emirates, Bahrain, Algeria, Tunisia, Djibouti, Saudi Arabia, Sudan, Syria, Somalia, Iraq, Oman, Palestine, Qatar, Kuwait, Lebanon, Libya, Egypt, Morocco, Mauritania, Yemen. (All are members of the Arab League).

AIDMO is the regional organization for industrial development in the Arab region with a mandate to achieve several objectives, including but not limited to the achievement of a harmonized and integrated quality infrastructure in the Arab world. By hosting the Arab Standards Centre, AIDMO is in charge of the regional activities on standards and Quality Infrastructure and acts as the coordinating regional body between all standard institutes in the region. AIDMO formed three regional Advisory Committees on Standardization, Accreditation and Metrology with a mandate to set up and implement the Arab Standardization strategy.

Contact: Khatauat Junction on France Street
Rabat - Agdal- Morocco - MA
Telephone: (212)(537)772600/01/04 **Fax:** (212)(537)772188
E-mail: aidmo@aidmo.org **Website:** www.aidmo.org

Contact: **Enda McDonnell**
Standards Senior Specialist at Abu Dhabi Quality and Conformity Council
4th Floor, Baniyas Towers, Najda Street, Al Markaziyah, Abu Dhabi City, Abu Dhabi
P.O.Box: 853, Abu Dhabi
Tel: +971 2 4066666
Fax: +971 2 4066677
http://www.qcc.ae

COPANT – Pan American Standards Commission

29 members and 9 adherents - Antigua and Barbuda, Argentina, Bahamas, Barbados, Bolivia, Brazil, Canada, Chile, Colombia, Costa Rica, Cuba, Dominican Republic, Ecuador, El Salvador, Grenada, Guatemala, Guyana, Haiti, Honduras, Jamaica, Mexico, Nicaragua, Panama, Paraguay, Peru, Saint Kitts and Nevis, Saint Lucia, Saint Vincent, Suriname, Trinidad and Tobago, Uruguay, USA.

The basic objectives of COPANT are to promote the development of technical standardization and related activities in its member countries with the aim of promoting their industrial, scientific and technological development in benefit of an exchange of goods and the provision of services, while facilitating cooperation in intellectual, scientific and social fields.

Contact: Ing. Guillermo ZUCAL
IRAM Consumer Committee Coordinator
IRAM Casa Central I Perú 552/6
C1068AAB I Buenos Aires I Argentina
Tel +54 11 4346 0682 gzucal@iram.org.ar

EASC - The Interstate Council for Standardization, Metrology and Certification

11 members: Azerbaijan, Armenia, Belarus, Georgia, Kazakhstan, Moldova, Russia, Tajikistan, Turkmenistan, Uzbekistan, Ukraine.

As a Regional Organization for standardization, the Council cooperates with the International Organization for Standardization ([ISO](http://www.iso.org)), the International Electrotechnical Commission ([IEC](http://www.iec.ch)), the

European Committee for Standardization ([CEN](#)) and other international and regional organizations for standardization, metrology, certification and accreditation.

Contact: Victor Vladimirovich Nazarenko
EASC President
Republic of Belarus
3 Melezh St., Minsk 220013
Telephone: + 375 17 288-42-22 Fax: +375 17 262-17-92
E mail: easc@easc.org.by

PASC – Pacific Area Standards Congress

26 Members – USA, India, Philippines, Indonesia, Bolivia, Brunei Darussalam, Mexico, Malaysia, Fiji, Russia, Columbia, Chile, Japan, Korea, Mongolia, Papua New Guinea, Peru, Hong Kong, Australia, South Africa, China, Canada, New Zealand, Singapore, Viet Nam, Thailand.

Countries on the Pacific Rim participate in this forum to:

1. Strengthen international standardization programs of the International Organization for Standardization (ISO) and the International Electrotechnical Commission (IEC) and to improve the ability of Pacific Rim standards organizations to participate in these programs effectively
2. Improve the quality and capacity of standardization in economies of the region
3. Support free trade within the region and with economies in other regions
4. Support improvement of economic efficiency and development of the region through the promotion of standardization
5. Interact with other bodies that represent elements of the standardization technical infrastructure, industry, consumers and government.

Among the 13 objectives of the organization is this one listed as 6.

6. To actively promote the benefits of standardization and conformance in the region to governments, industry and consumers.

RNF – Réseau Normalization et Francophonie

27 members - Algeria, Belgium, Benin, Burkina Faso, Burundi, Cameroon, Canada, Congo RD, Congo Brazzaville, Cote d'Ivoire, France, Gabon, Haiti, Kenya, Lebanon, Luxembourg, Mali, Mauritania, Mauritius, Madagascar, Morocco, Niger, Rwanda, Senegal, Switzerland, Togo, Tunisia.

Note from Norma: At the invitation of Marie-Claude Drouin of the Bureau de Normalisation du Québec who holds the RNF Secretariat, I attended a meeting at the 2014, ISO General Assembly of the RNF to identify and support ways of linking the RNF members to issues of importance to consumers. The RNF has developed a web-based platform which will include a link to ISO COPOLCO that will permit access to the French language resources including COPOCLO publications and the quarterly newsletter.

Contact: Marie-Claude Drouin
Bureau de Normalisation du Québec
333, rue Franquet Québec (Québec) G1P 4C7 CANADA

REPORT OF THE ARSO GENERAL ASSEMBLY TRAINING EVENT – Consumers in Africa – making a difference in standards

African Union Headquarters, Addis Ababa, Ethiopia – 14 August 2015

Background

The African Organization for Standardization (ARSO) is the regional group of ISO members in Africa, based in Nairobi, Kenya. In 2013 it established two subcommittees: on conformity assessment matters (ARSO CACO), and consumer policy (ARSO COCO) in order to strengthen awareness and capacity among the ARSO membership in these two areas. The ARSO Secretary General and past COPOLCO Chair then started discussions about cooperation between ARSO COCO and ISO/COPOLCO, which culminated in an agreement to hold a training seminar focusing on consumer participation, food safety and public services issues. This half-day event formed part of the ARSO General Assembly and took place at the African Union Headquarters on 14 August 2015.

ARSO COCO's role

ARSO COCO promotes consumer participation in African standardization processes as a means of availing them an avenue to articulate consumer interests in the standardization and conformity assessment. It reviews consumer needs, plans and advises the ARSO Council on programmes that meet the needs of consumers. It has the following general objectives:

- Provide a forum for the exchange of information and experience on standards
- Provide information on how standardization benefits consumers and how consumers can contribute to standards development
- Mobilize African consumer organizations to participate in national and regional standards setting
- Provide informational material on standards related to consumer issues
- Ensure that African standards produced are relevant to the market
- Involve consumers in standards development activities by providing African representation to the international community of consumer specialists for issues of consumer policy
- Encourage the representation of the African consumer interest in the creation of technical regulations

Objectives of the ARSO COCO training event

In support of ARSO COCO's objectives, this training event aimed to:

- Raise awareness among ARSO members of the benefits of consumer interests' involvement with standardization, through examination of specific case studies and national examples
- Encourage ARSO members to strengthen national mechanisms for consumer participation and to participate in regional and international structures for consumer participation (ARSO, COPOLCO and Consumers International)
- Promote networking and dialogue among ARSO members on ways to develop consumer engagement, taking into account each country's unique needs and profiles.

Support and organization

ISO/COPOLCO provided the trainers, designed the overall programme, developed the training materials, and drafted a post-event report. The ISO Academy provided financial support to one

trainer, advised on programme development, developed a portal on Cvent to register some participants and distribute materials; will analyze feedback questionnaires, and will produce certificates of attendance. ARSO offered the support of a project coordinator managed general registration and information for the participants, the opening speaker (ARSO President), a general session facilitator (ARSO Secretary General) and an additional speaker from Proctor & Gamble. The Ethiopian Standards Agency (ESA) provided the venue, logistical support for participants and two speakers.

Participation

Ninety-nine representatives from thirty countries attended the training event; they constituted most of the current membership of ARSO and attended the rest of the plenary meeting. Most representatives were CEOs or directors of the NSB, but delegations also included representatives of government and consumer protection agencies. Representatives of consumer organizations came from Côte d'Ivoire, Ethiopia, Nigeria and Zimbabwe. Furthermore, international organizations such as UNIDO, SANAS/AFRAC, and ECOWAS were represented. The full list appears at Annex C.

Format and design of the programme

The training event was held from 8:30 to 13:30, with a coffee break. After Dr Joseph Odumodu (ARSO President) and Dr Elizabeth Stampfl-Blaha (ISO Vice-President, Technical Management) delivered opening addresses, Mr David Bell (Director of External Policy, BSI) introduced the general context of consumer participation in ISO and invited Ms Dana Kissinger-Matray (Secretary of ISO/COPOLCO) and Ms Sadie Homer (Senior Policy Advisor, Consumers International) to respond in turn to questions in a dialogue format, supported by PowerPoint presentations in the background. The speakers regularly paused to invite the participants to comment and to ask questions. This allowed participants to engage more actively with the material and to challenge their own and each other's assumptions.

The speakers addressed the following themes:

- What are consumers' expectations for goods and services?
- What are some of the biggest concerns that consumers have had in goods and services, i.e. discrepancies between expectations and realities?
- What can standards do to address these concerns?
- What exactly is a standard?
- Why is stakeholder input in standards-setting so important?
- What exactly is a "consumer representative"?
- What added value can consumers bring to standards development?
- How is consumers' input organized into the ISO system?
- How is consumers' input organized into the CI standards area?

The speakers and participants then considered:

- What are the barriers to consumer participation?
- What are ways to overcome those barriers?
- What resources are available for national standards bodies?
- What resources are available for consumer organizations interacting with the national standards body?

A few examples of consumer input into market surveillance actions were considered to show how consumer issues, standards and conformity assessment could work together to achieve good outcomes for consumer protection.

The speakers each presented some national case examples from Europe and Africa of how this happens in practice. The audience was invited to comment on their own national models and issues. They noted that “One size does not fit all”; success in outreach and engagement depended on taking account of many factors, including government support for consumer protection issues, the country’s economy, legislative framework, literacy levels, and national priorities for standardization.

The first section concluded with presentations from two Ethiopian experts, Mr Yohannes Melesse (ESA), who spoke extensively on ESA’s involvement with ISO TC 34, *Food products* and involvement of consumer organizations; and Mr Zelalem Zamede, representative of the Consumer Protection Organization of Ethiopia, who addressed coordination of consumers’ interest in food safety and security issues, and outreach to consumers, including women and young people.

As a case study from a manufacturer’s point of view, Dr Charles Azuka from Proctor & Gamble gave a presentation on cosmetic safety evaluation and its relevance to the African consumer. His presentation emphasized the importance of adequate testing, and adapting personal consumer products to the biological characteristics of people in chosen target markets in order to meet consumers’ requirements for safety and fitness for purpose.

The training event concluded with a Question and Answer session and panel discussion led by the ARSO Secretary General, followed by closing remarks from Mrs Almaz Kahsay, Director General of ESA, and Mrs Eve Gadzikwa, ARSO President-Elect.

Observations

The level of engagement with consumer organizations (as well as public interest groups and NGO’s) varied considerably from country to country. They ranged from good consumer stakeholder participation, including representation at board level, within strategy/technical committees and mirror groups, to little or no relationship. It was notable that the NSB’s who had active participation with their consumer organizations/stakeholder group were those whose governments have adopted and implemented a Consumer Protection Act within their legislation. The consumer organizations in these countries also tended to be well established, sustainable bodies with professional employed or volunteer staff.

NSB’s that had little or no consumer stakeholder representation cited similar problems in establishing one. These included:

- The lack of existence of any recognized consumer organization
- The lack of a broad based consumer organization (but single issue NGO’s)
- The presence of many small consumer groups with no central contact or reference point
- Consumer organizations’ lack of resources, financial and human, to participate in standardization
- Consumer organizations with other priorities than standardization or a lack of awareness of the need and role of consumer participation in standardization.
- Consumer organizations who believe that participation in standard would compromise their ‘independent’ status

The participants were engaged, interested in consumer issues and consumers as a stakeholder group. Interventions and questions were forthcoming throughout the session.

ARSO were commended for hosting this first meeting of ARSO COCO alongside its General Assembly and for its recognition of the need for a consumer policy committee in addition to a committee on conformity assessment.

Recommendations from the training participants to ARSO COCO

Upon invitation from the ARSO Secretary General, who was acting as session chair, panelists and the floor offered ARSO COCO the following recommendations for its consideration:

- To maintain and build its relationship with ISO COPOLCO, to include representation in ISO COPOLCO. The participation of other regional bodies, such as AP COPOLCO and ANEC is already established and may act as a guideline
- To continue to meet alongside ARSO GA and coordinate with ISO COPOLCO/ISO Academy to provide the training needs required by ARSO COCO members
- To make best use of available technology to interact between ARSO COCO members and ISO CS
- To encourage members of ARSO to seek membership of ISO COPOLCO if they are not already members
- To encourage the members of ARSO to seek membership of ARSO COCO and participate in its work programme and meetings
- To encourage the members of ARSO COCO to promote (through sharing of knowledge) the need for consumer stakeholder participation within its NSB and with other stakeholders, including consumer organizations. A data base of NSB case studies of consumer stakeholder participation in ARSO COCO countries could be initiated which would share the range of models used across the continent, including financial and human aspects
- To encourage the participation of NSB consumer stakeholder groups in ARSO COCO where an established relationship exists
- To encourage ARSO COCO members who do not have or have a fragmented relationship to undergo a review of the consumer movement in their countries in order that they may develop a strategic approach to building such a relationship
- To build an ARSO COCO strategy to respond to the feedback and recommendations of the ARSO COCO session, recognizing the rapid development of socio-economic factors, national policy and regulation and the role of consumer groups in Africa.

Conclusions

The trainers received positive oral feedback from some of the participants, and a summary of the completed evaluation questionnaires is available upon request. The interactive presentation format, with time for questions and answers, was favorably received and generated a positive response and active participation from the audience.



International Organization for Standardization
Organisation internationale de normalisation
Международная организация по стандартизации

AGENDA ITEM 15 REVISION OF ISO/IEC GUIDES 14 AND 41



AGENDA ITEM 15 REVISION OF ISO/IEC GUIDES 14 AND 41

COPOLCO ACTION: COPOLCO is invited to note/comment on the report.

1 Introduction

As a policy committee, COPOLCO is mandated to produce [ISO/IEC Guides](#) on broad topics of consumer interest as they affect ISO's technical work. This report focuses on progress in the revisions of ISO/IEC Guide 14 and 41, although a brief update for other Guides appears below.

In 2014 COPOLCO published the revisions of ISO/IEC Guide 51, *Safety aspects – Guidelines for their inclusion in standards*, and ISO/IEC Guide 50, *Safety aspects – Guidelines for child safety in standards and other specifications* in cooperation with the IEC Advisory Committee on Safety.

Since then, work has been progressing on the revisions of these ISO/IEC Guides:

Guide 14, *Purchase information on goods and services intended for consumers*,

Guide 41, *Packaging – Recommendations for addressing consumer needs*

Guide 46, *Comparative testing of consumer products and related services – General principles*

Guide 76, *Development of service standards – Recommendations for addressing consumer issues*

2 Updates on comparative testing and consumer issues in services

Guide 46 on comparative testing: the COPOLCO Chair, who is also convenor of ISO/COPOLCO WG 12, led the final meeting by WebEx to discuss comments resulting from the Committee Draft consultation on ISO/IEC Guide 46. The Chair and Secretary finalized the draft for enquiry which will close on 16 September.

Guide 76 on addressing consumer issues in services: At its 2015 Plenary COPOLCO noted the results of the systematic review consultation on ISO/IEC Guide 76, and resolved to launch its revision. COPOLCO also approved the Terms of Reference of ISO/COPOLCO working group 18, *Consumer issues in standardization of services*.

A complete update on the work of WG 18 appears under items 9 and 10.

3 Guide 14 on purchase information for consumers

ISO/COPOLCO Working Group 15, led by Michele Althoff (ANSI-USA), finalized the Committee Draft of ISO/IEC Guide 14 in early 2016. It is now under consultation among ISO/COPOLCO members and IEC National Committees until 14 May. Early indications are that the draft is strongly supported, with some comments. The next step is for the working group to deal with comments and produce the final draft for enquiry (ISO/IEC Draft Guide 14).

The COPOLCO Secretary will provide an update on the result of the ISO/IEC CD Guide 14 consultation at the COPOLCO Plenary.

./.

Guide 14 will therefore shortly be in a sufficiently advanced stage to form the basis for a proposal to the ISO Technical Management Board on its conversion into an International Standard, as agreed by COPOLCO Resolution 17/2015 (overleaf). COPOLCO agreed that the Guide, formerly aimed primarily at standards-writers, would better serve manufacturers and service providers (and the ISO community at large) as another type of deliverable.

This revision is converging with COPOLCO's recommendation to develop a new work item proposal for business-to-consumer communication, designed to give guidance and principles for transparent, comparable and reliable information about goods and services including on-line communications. The aim is to develop a good practice guideline for suppliers on product information for consumers which will comprise the revision and extension of the currently-existing ISO/IEC Guide 14 and take account of current social trends and state-of-the-art technology.

A PowerPoint presentation about ISO/IEC Guides, with more information about Guide 14, is available upon request.

4 Guide 41 on packaging

A first coordination meeting of this working group took place during the 2015 plenary week, with another outreach meeting planned on 15 June. Sandra Herrera (ICONTEC - Colombia) has been joined by Christine Heemskerk (BSI - United Kingdom) as co-convenor of ISO/COPOLCO Working Group 16.

This working group benefits from the participation of experts from ISO TC 130, *Graphic technologies*, and ISO TC 122, *Packaging* as well as COPOLCO.

The revision of ISO/IEC Guide 41, *Packaging – Recommendations for addressing consumer needs*, began early in 2016, with the circulation of the first working draft and an issues paper for comment by the members of the working group.

The working group will hold its first drafting meeting on 28-29 July 2016, in Reston, Virginia (USA) hosted by ANSI at the premises of the Association for Packaging and Processing Technologies (PMMI).

COPOLCO Resolution 17/2015

Global marketplace working group (1)

COPOLCO

thanks the global marketplace working group for its report at COPOLCO 18/2015,

approves the activity template on business-to-consumer communication appearing at Annex 1 to COPOLCO 18/2015,

notes the ongoing revision of ISO/IEC Guide 14, *Purchase information on goods and services intended for consumers*,

supports future conversion of ISO/IEC Guide 14 into an International Standard, upon its publication.



International Organization for Standardization
Organisation internationale de normalisation
Международная организация по стандартизации

AGENDA ITEM 16 REPORTS FROM LIAISON ORGANIZATIONS



International Organization for Standardization
Organisation internationale de normalisation
Международная организация по стандартизации

AGENDA ITEM 16.1 INTERNATIONAL ELECTROTECHNICAL COMMISSION



AGENDA ITEM 16.1 REPORT FROM THE INTERNATIONAL ELECTROTECHNICAL COMMISSION (IEC)

COPOLCO ACTION: members are invited to note this report.

The IEC (International Electrotechnical Commission) is the world's leading organization that prepares and publishes globally relevant International Standards for all electric and electronic devices and systems. It brings together 167 countries, representing 98% of the world population and 96% of world energy generation. Close to 20 000 experts cooperate on the global IEC platform and many more in each member country. The IEC also supports all forms of conformity assessment and administers four Conformity Assessment Systems (IECEE, IECEx, IECQ and IECRE) that certify that components, equipment and systems used in homes, offices, healthcare facilities, public spaces, transportation, manufacturing, explosive environments and during energy generation conform to them.

IEC work covers a vast range of technologies: power generation (including all renewable energy sources), transmission, distribution, Smart Grid and Smart Cities, batteries, home appliances, office and medical equipment, all public and private transportation, semiconductors, fibre optics, nanotechnology, multimedia, information technology, and more. It also addresses safety, EMC, performance and the environment.

IEC members are [National Committees](#) (NCs) representing the entire range of electrotechnical interests in their country, notably companies and businesses, industry associations, educational bodies, governmental and regulatory bodies and consumers.

Hereafter are listed recent IEC activities of potential interest to ISO/COPOLCO.

Wearable Smart Devices (WSD)

Wearable Smart Devices (WSD) are smart electronics that can be embedded in accessories or clothes (near body), patchable (on body), or implantable (in body). According to the forecast from IDTechEx in 2014, the market size for WSDs will reach 70 billion US dollars by 2024. Initially basic infotainment (not web connected or diagnostic) and passive medical, healthcare, and fitness devices represent the biggest share of the current market (around 50% of value). The March 2016 issue of [IEC e-tech](#) extensively covers mobile healthcare, also known as *mHealth*.

In June 2015, the SMB agreed to set up Strategic Group SG 10, *Wearable Smart Devices*, with the following scope: terminology and agreed understanding of WSD, market needs, inventory of activities within IEC, inventory of activities outside IEC, priorities of work, and coordination of activities within IEC. Several IEC TCs such as 47, 62, 77, 100, 106, 108, 110, 111, 119, and CISPR were identified as relevant to this area and collaborate with each other in SG 10.

The discussion at the last SG 10 meeting resulted in several agreed terminologies related to WSD. The meeting also discussed the input provided by the members on WSD related standardization activities within IEC TC/SCs and other organizations. SG 10 agreed that the WSD matrix reviewed at the meeting will be the basis for consideration to find gaps and determine priorities. It was identified that electronic textile related items are not addressed by any TC in IEC and recognized as gaps. Also, there are some items across the overall WSD areas that are not yet addressed by the existing TCs.

The meeting agreed to prepare a proposal for a new TC based on the updated matrix by the next SMB meeting in June 2016. Titles for the new TC were also explored. The high priority standardization work will be terminology, safety, reliability and performance evaluation.

Active Assisted Living (AAL)

Active Assisted Living (AAL) is the term used to describe the systems, products and services that enable vulnerable and ageing people to live safely at home longer. These items include alarm systems, home monitoring, telehealth products, communications and robotics.

These systems, services and products have largely grown ad hoc, in response to the ageing of the population, and driven by technological developments. This led the IEC to set up a System Committee on Active Assisted Living ([SyC AAL](#)) in 2015 to look at the international standardization needs in order to foster market development and protect the end user. A SyC offers a new type of standards development approach, which brings together many stakeholders with different types of expertise to develop International Standards at a systems level.

On 29 April, SyC AAL held a workshop on “AAL Risk Assessment” in New Zealand. The workshop used ISO 31000 *Risk management process* and IEC 31010, *Risk management -- Risk assessment techniques*, as a basis for discussions and for potential application to practical situations.

Low Voltage Direct Current (LVDC)

The need for electricity access in developing economies is driving the urgency for standardization of low voltage direct current (LVDC), under 1500 V. Around 1,3 billion people worldwide don't have any access to electricity. LVDC and its associated technologies offer the potential to deliver safe, efficient and green electricity to many of them.

When establishing SEG 4, *Systems Evaluation Group - Low Voltage Direct Current Applications, Distribution and Safety for use in Developed and Developing Economies*, the SMB requested the SEG to evaluate the market, the existing and future applications, and the related most used voltages. SMB also asked to review the inventory of existing standards, identify eventual gaps, and propose a strategy to develop the LVDC standardization in the IEC. SEG 4 has grouped the various tasks requested in six work packages which were assigned to six SEG 4 teams.

In October 2015, over 200 experts were invited to the [IEC BIS International Conference on LVDC](#). This event highlighted how standardization work is key to achieving faster, cost-effective development of LVDC distribution networks. Participating experts contributed towards defining and structuring the standards-driven deployment of LVDC across industries and applications.

Alarm and electronic security systems

The market for alarm and electronic security systems will continue to expand in coming years, fed by the quest for increased safety and security, constant concern over terrorism and crime as well as the need to protect critical infrastructure. IEC TC 79 develops International Standards for alarm and electronic security for a wide range of applications, including new ones like medical and social alarm systems, which are driven by the needs of an ageing population. TC 79 recently published new parts of the IEC 60839 series, *Alarm and electronic security systems*

TC 79 also works with ISO and ITU active in some aspects of standardization for alarm and electronic security systems. This work is carried out within [ISO/IEC/ITU-T SAG-S](#) (Strategic Advisory Group on Security), which oversees standardization activities relevant to the field of security.

Electric vehicles: Wireless charging

The growing number of electric vehicles (EVs) on the roads relies on cabled connections to the grid for charging. Wireless power transfer (WPT) is seen as an attractive alternative to plug-in charging. After having standardized AC (alternating current) and DC (direct current) fast and slow charging of EVs, including the charging infrastructure, IEC TC 69, *Electric road vehicles and electric industrial trucks*, has now published IEC 61980-1:2015, *Electric Vehicle wireless power transfer (WPT) Systems*. This is the first IEC International Standard that covers the wireless charging of EVs and all related equipment. It provides the general requirements to be satisfied by the charging systems and applies together with IEC 61980-2 and IEC 61980-3 which are under development.

Environment: Hazardous substances control

Increasingly strict environmental regulations directly impact the manufacturing of electrical and electronic devices. The focus is on product waste management and control of the use of hazardous substances and chemicals in the manufacturing process. This leads to increased environmental consideration during product and systems design. The aim is to facilitate waste management and recycling with a circular economy approach. IEC TR 62474-1:2015(E) prepared by TC 111, *Environmental standardization for electrical and electronic products and systems*, facilitates the material declaration process for manufacturers. Among other things, it includes mandatory reporting requirements, methods and thresholds for key substance groups.

E-waste: Universal chargers

After the universal charger for mobile phones and the single charger for notebooks that were standardized by the IEC in the past, TC 100 has now published IEC 62680, *Universal serial bus interfaces for data and power*, which lays the foundation for the development of a "universal charger" for most of the other ICT portable devices.

Audio visual equipment: Power consumption

With energy efficiency considerations topping the charts of regulators, all electronics and in particular audio visual equipment is under close scrutiny with regard to power consumption. The IEC 62087-1 to 6 *Audio, video, and related equipment - Determination of power consumption* series prepared by TC 100 provides the test suites that are needed to measure the energy efficiency of equipment such as TVs, audio, video recording, set-top-boxes and the like.

Fuel cells

There is a growing demand for new techniques for storing energy at the same time as addressing other concerns such as producing lower emissions and providing energy efficient alternatives to fossil fuels. Fuel cells work by converting an external fuel source such as hydrogen with an oxidant to produce a chemical reaction. There is zero impact on the environment since the only by-products of the production of electricity are water and heat.

TC 105 expects the publication of IEC 62282-3-400, *Fuel cell technologies - Part 3-400: Stationary fuel cell power systems - Small stationary fuel cell power system with combined heat and power output* in October 2016.



International Organization for Standardization
Organisation internationale de normalisation
Международная организация по стандартизации

AGENDA ITEM 16.2 ACTIVITIES OF CONSUMERS INTERNATIONAL WITH RESPECT TO STANDARDIZATION



AGENDA ITEM 16.2 ACTIVITIES OF CONSUMERS INTERNATIONAL – REPORT BY A CI REPRESENTATIVE

COPOLCO ACTION	Members are invited to note/comment on the report.
-----------------------	--

Julie Hunter, Consumers International's nominated expert to ISO/TC 290, Online reputation, and Chair of ANEC's Services Group, will be representing the consumer stakeholder and looking at what the revision of ISO/IEC Guide 76, *Development of service standards – Recommendations for addressing consumer issues* can offer as a tool to develop credible services standards that meet the needs of the demand side of service businesses – consumers.

CI member meeting

As usual, Consumers International will be holding a member meeting prior to the plenary to discuss CI's engagement and priorities in COPOLCO, and work of common interest, in matters relating to standards, as well as the broader context of the consumer movement.

Many organizations, working in the interest of consumers, are able to join CI, as a member or in our new category as a 'supporter'. The supporter category provides a unique opportunity for individuals and organizations who are sympathetic to our cause and keen to support our fight for a fairer, safer and more sustainable future for all consumers, to have stronger links with CI. If you are interested please come along to the meeting and learn more about the global consumer movement. Look out for announcements but this usually takes place after the workshop.

CI's Strategy 2015 - 2020: Unlocking consumer power on a global scale

You can read our strategy here:

<http://www.consumersinternational.org/who-we-are/strategic-plan/>

WCRD 2016: We want to get #AntibioticsOfftheMenu.

Antibiotic resistance is developing and spreading at a rate that cannot be contained by the development of new drugs. If measures are not taken urgently to reduce global consumption of antibiotics, we could face a return to an era where simple infections can kill. The widespread practice of routinely dosing farm animals with antibiotics is contributing to this threat. Around half of the antibiotics produced globally are used in agriculture, with much of this being used to promote faster growth and to prevent, rather than treat, disease. Despite worldwide concern about the overuse of antibiotics, their use in agriculture is due to increase by two thirds by 2030: from 63'200 tons in 2010, to 105'600 tons in 2030.

We organized an international social media campaign using the campaign tool Thunderclap to raise awareness of the need for KFC, McDonald's and Subway to make global time bound commitments to stop sourcing meat from animals routinely given antibiotics. The campaign message was delivered to 2 million people. You can download the report at:

<http://www.consumersinternational.org/our-work/food/key-projects/antibiotics>



WORLD CONGRESS 2015

CI's 20th World Congress featured panels and interactive discussions across a range of important consumer issues, all featuring experts from across the consumer movement, wider civil society organizations, government and the private sector and live Q&As from the audience. Delegates, including the CI membership, shared ideas, successes and discussed new ways to operate going forward, inspiring each other to work together for greater global impact.

Amanda Long opened the Congress with a challenge to members: "If CI and its Members can collaborate more effectively; if we can better coordinate our campaigning activities; if we can be a federation in deed as well as in name, then we too will be multinational in our reach and see our influence and impact multiply."

Messages were received from other international organizations including Roberto Carvalho de Azevêdo, Director General of the World Trade Organization who talked to participants at CI's World Congress about the relationship between trade and consumers; connecting to CI's trade programme.

Watch it here:

<https://www.youtube.com/watch?v=BVliOa7-7Cc&list=PL7YVP935ytF8uNbwhVvgUU9dZy0e3T1nx>

Consumers International (CI) announced Bart Combée as its new President. Bart is also President of the Netherlands' consumer organization, Consumentenbond. Gilly Wong, Chief Executive of the Hong Kong Consumer Council, also joins him as Vice President of CI.

ISO COPOLCO at CI CONGRESS 2015

Standards had a strong presence at Congress with the attendance of ISO acting Secretary-General Kevin McKinley speaking at a number of events across the programme. Dana Kissinger Matray represented ISO COPOLCO and active COPOLCO members from around the Globe also attended.

The SIDA sponsored programme brought 28 delegates from national standards bodies, governments and (8) CI members, bringing the voice of developing countries consumer protection needs to this event and enabling broad participation throughout congress.

Connecting with Consumers - Empowerment through standards

This joint ISO-CI one day training, supported by ISO and SIDA, was dedicated to helping create valuable connections between standards development organizations and consumer representatives with the two-fold aim: to strengthen standards setting organizations' capacity to engage with consumers; and to enhance consumer stakeholders' ability to participate in technical areas of consumer interest. Another objective was to help consumer associations interact more effectively with standards development organizations and participate in ISO and Consumers International activities, in areas where standards have a favorable impact on consumer protection. Amanda Long, CI's Director General opened the afternoon outreach session and endorsed the importance of standards in consumer protection. High profile panelists included two CI presidents and past COPOLCO Chair, Kim Jai Ok.

The day comprised a morning training, followed by an open outreach session in the afternoon. Both events attracted not only the sponsored participants, but many delegates from more than 500 attending.

A panel during the main congress focused on **'Standards today, Legislation tomorrow – how can the international consumer movement have better impact'** and included an interview with Mr McKinley.

Consumers International launches bid for United Nations recognition of World Consumer Rights Day

Given the historic adoption of the revised UN Guidelines for Consumer Protection achieved at the end of 2015, which recognized important new protections for consumers, **there is now an urgent need to raise awareness of these protections for consumers around the globe. UN recognition of World Consumer Rights Day can play a crucial part in this.** At a time when Consumers International has unprecedented engagement from consumer protection agencies around the world, we have an excellent opportunity to campaign for UN recognition for the most important day in the global consumer rights calendar.

The activities of Consumers International within the policy and technical work of international standards are given below:

COPOLCO

Consumers International has liaison status with COPOLCO and attends COPOLCO meetings and the COPOLCO Chair's Group. Sadie Homer (senior policy advisor) is co-responsible for training activities within the Consumer participation and training group.

Consumers International congratulates ISO Academy and its sponsors for bringing developing country members to participate in COPOLCO 2015. In an increasingly difficult donor climate it is even more important to support under-represented stakeholders. Theirs are the voices not often heard but vital in producing credible international policy and standards.

CI has also been active in the Global Marketplace WG, with Robin Simpson and Sadie contributing to the further development of standards developed under the GMWG, on mobile payments (ISO TC 68) and energy – service to users (ISO TC 242). Please see the GMWG report for details.

Corporate Social Responsibility (ISO SR WG)

CI continues to co-ordinate the consumer stakeholder group, and also participates in the PPO (Post Publication Organization). Ian Fenn, CI's Sustainable Consumption Project Coordinator, presented CI's work on the United Nations Sustainable Development Goals (UN SDGs) and how it could be linked to ISO 26000 at a workshop in Stockholm in November 2015. He also represented CI at the PPO meeting along with Jens Henriksson (Swedish Consumers Association).

ISO TC 68 SC 7 WG 10: Mobile payments

Consumers International established liaison D status to WG 10 in September 2012. Robin Simpson and Sadie Homer were accepted as experts to the WG. CI has continued to actively participate in WG 10 meetings since this time, including Chicago in September 2014 where CI made good progress in including comments from their members and ensuring that key consumer protection issues were addressed by the standard.

Unfortunately, the ISO 12812 DIS failed to succeed by one vote. After much debate it was decided to go to a second round of votes, but only paper 1 – the framework document will be issued as a second DIS. The remaining four papers covering specific aspects of mobile payments: security and data protection; financial application management; mobile payments to a person (P2P); mobile payments to a business (C2P) will be issued as Technical Specifications.

Consumers International URGES COPOLCO members to support these documents and lobby for a positive vote. The voting starts 2016-05-17, and closes on 2016-07-13.

If anyone would like to have more details, please do speak to Sadie Homer or Robin Simpson.

ISO/PC 294: Guidance on unit pricing

Ian Jarrett (CFA) is CI's nominated expert on the project committee for Unit Pricing. A Consumers International position paper was prepared and endorsed by members, in time for the meeting of the PC in Singapore in April 2016. Ian reports good progress was made and the final standard looks to be a useful tool for all. Ian has also presented to Malaysian Standards users, who have also been active on the topic, producing two videos; and with CI's regional office in Kuala Lumpur. The next meeting will be in Tokyo in late November.

ISO TS 20245: Second hand goods

We await the commencement of work on converting the TS into an ISO standard.

ISO 242: Guidelines for the assessment and improvement of energy services to users

The ISO 50007 DIS has been approved, with a 93% approval rate. Robin Simpson, CI's expert has made a major contribution to the drafting of the document and has made significant comments to the DIS. The next meeting of the WG will be held during the week of 13th June 2016 in Sweden.

CI /ANEC project

ANEC are supporter members of CI and continue to cooperate under the terms of an MOU on a variety of standards work. Please see ANEC's report for more details.

ISO TC 290: Online reputation

Work continues on developing this standard. Julie Hunter is the CI/ANEC expert and she has made substantive comments to improve the scope and content of the standard which aims to give good practice guidance for online review processes.

The next face-to-face meeting is scheduled in Berlin, Germany, on 12th-15th September 2016.

IEC TC 61: Safety of electrical household products

The CI/ANEC representative continues to attend IEC TC 61. ANEC has carried out research and also works at CENELEC level to ensure the standard reflects consumer needs and issues, specifically those of vulnerable consumers. The project is supported by ANEC and CI/ANEC members from Spain, Australia and Hong Kong.

IEC TC 181 Safety of toys

CI/ANEC continues to work in the ISO TC 181 committee. This work is supported by CI/ANEC experts from Australia, Denmark and Sweden, who have been co-ordinating to improve the standard.

IEC ACOS

The CI/ANEC representation to ACOS has continued through correspondence and participation.

Vehicle and traffic safety

UNECE WP 29 and GRSP: ANEC co-ordinates the representation of consumers on behalf of CI at these meetings.

A full report can be found in the ANEC report.

ISEAL

ISEAL is a supporter member of CI. Sadie Homer sits on their steering committee developing good practice guidance on claims made by and about sustainability standards systems, which will be published this year. She also participated in the steering committee, which developed ISEAL's credibility principles.



**AGENDA ITEM 16.3 RECENT ACTIVITIES OF THE ORGANISATION
FOR ECONOMIC CO-OPERATION AND
DEVELOPMENT (OECD) – COMMITTEE ON
CONSUMER POLICY (CCP)**



AGENDA ITEM 16.3 REPORT FROM THE OECD COMMITTEE ON CONSUMER POLICY (CCP)

COPOLCO ACTION: members are invited to note and comment on this report.

The CCP focuses on building consumer confidence and engagement in the global economy. The following events may be of interest to ISO/COPOLCO members.

1. OECD 2016 Ministerial

The CCP has contributed to the organization of the OECD Ministerial meeting on the Digital Economy to take place in Mexico on 21-22 June 2016:

<http://www.oecd.org/internet/ministerial/>

There will be two panel discussions under the theme of consumer trust in the digital economy.

2. Release of Revised E-Commerce Recommendations

E-commerce has evolved dramatically since 1999, when the OECD Council adopted the first international instrument for Consumer Protection in the Context of Electronic Commerce (“1999 Recommendation”).

On 24 March 2016, the OECD Council revised this instrument and the Recommendation of the Council on Consumer Protection in E-commerce (“the revised Recommendation”) which now addresses new and emerging trends and challenges faced by consumers in today’s dynamic e-commerce marketplace.

<https://www.oecd.org/sti/consumer/ECommerce-Recommendation-2016.pdf>

Report Submitted May 3, 2016
Jay Jackson (Canada)
OECD CCP Liaison to ISO/COPOLCO



**AGENDA ITEM 16.4 DEVELOPMENTS OF CONSUMER INTEREST
IN EUROPEAN STANDARDIZATION: REPORT
BY AN ANEC REPRESENTATIVE**

AGENDA ITEM 16.4 REPORT BY ANEC

COPOLCO ACTION COPOLCO is invited to comment on/approve the report.

1. Horizontal Issues

New ANEC governance bodies

ANEC's General Assembly (ANEC/GA) in Brussels on 18-19 June 2015, ratified the membership of the General Assembly for the 2015-2019 term. Of the 33 countries eligible for membership, a record 32 are now represented.

The meeting re-elected Arnold Pindar (UK) as ANEC President for a further term of two years (2015-2017), Dermott Jewell (Ireland) as Vice-President and Benedicte Federspiel (Denmark) as Treasurer.

The meeting also elected the members of the ANEC Steering Committee (ANEC/SC), the board of the association, for the 2015-2017 term. The President, Vice-President and Treasurer are joined by Grace Attard (Malta), Libor Dupal (Czech Republic), Jens Henriksson (Sweden), Marino Melissano (Italy) and Audun Skeidsvoll (Norway & EFTA Consumer Council).

The 2016 ANEC General Assembly & 21st anniversary event will be on 14 & 15 June in Brussels. ANEC's 21st anniversary will be celebrated during an extended dinner, preceded by a cocktail. Keynotes are planned from VIP guest speakers (European Commissioner(s), EFTA, MEP(s)).

ANEC's Work Programme 2016

The ANEC Work Programme for 2016¹ sets out the activities ANEC plans to undertake in the year. It lists detailed areas of activity under the priority areas – Accessibility, Child Safety, Digital Society, Domestic Appliances, Services, Sustainability and Traffic – as well as horizontal activities on policy.

The priorities reflect the Annual Union Work Programme for Standardisation 2016², (AUWP) adopted by the European Commission (EC) in January. ANEC commented the draft AUWP and is pleased the Commission took many of our points into account.

¹ ANEC Work Programme 2016 (public version), <http://goo.gl/h1mTW9>

² AUWP 2016 <http://goo.gl/9Alj9t>

We marked the publication of the AUWP with a [position paper](#)³.

Joint Initiative on European Standardization (JIES)

On 28 October 2015, the EC presented a Single Market Strategy to deliver a deeper and fairer European Single Market to benefit consumers and businesses. The Strategy recognises that standardization has an essential role to play in the completion of the Single Market. To this end, it sees a “Joint Initiative on European Standardization” (JIES) comprising the EC, European Standardization Organizations and stakeholders from across the wider standardization community. The JIES aims to create a cross-party (but voluntary) commitment on using standardization to support the priorities of the Juncker Commission⁴. This will be done through both political commitments and concrete actions set out in a document the parties will be invited to sign at a meeting on 13 June 2016 under the present Dutch Presidency of the European Council.

The first JIES plenary was on 23 November 2015 in Brussels, attended by the ANEC Secretary General. Following the plenary, an Editorial Committee, in which ANEC participates, has been set up to develop the document. Drafting started with a first meeting of the Editorial Committee of 8 January 2016 ending on 15 April. The definitive draft was presented to a second plenary meeting on 29 April.

After the signature on 13 June, a Steering Group should be set up to develop detailed actions to implement the JIES. These should be announced on 14 October 2016, World Standards Day.

ANEC trusts the JIES will seek more inclusiveness in the European standardization process and encourage EU Member States to support the participation of weaker stakeholders in national standardization more fully. We also support the JIES goal to encourage development of European standards for consumer services (albeit limited in the absence of harmonising European legislation).

The EC also plans to publish a “Standardization Package II” on 1 June as a key step in marking the 18th month of the Juncker Commission. There will also be a package on the Capital Union, EU as international actor and EU investment fund.

The Standardization Package II will focus on the JIES and include a long-awaited EC Communication on services standardization. The JIES Steering Group will also receive its mandate to work.

ANEC contributes to discussions on TTIP and standards

The possible Transatlantic Trade & Investment Partnership (TTIP) remains high on the Brussels political agenda during 2015 and into 2016.

On 31 March 2015, the Transatlantic Consumer Dialogue (TACD) hosted a workshop, ‘TTIP myths debunked – What’s really in it for consumers?’ supported by BEUC, the mainstream European

³ ANEC comments on Preliminary Draft Annual Union Work Programme on European Standardization 2017, <http://tinyurl.com/gmwkhg2>

⁴ <http://goo.gl/cieZDY>

Consumer Organization. Its aim was to look at some common misperceptions and claims revolving around TTIP. Discussions focussed on the claims surrounding the economic gains of the trade deal, and negotiations covering technical standards and other technical barriers to trade (TBTs).

Later that day, another event, 'Regulatory Aspects of TTIP: A Transatlantic Consumer Perspective', was held in the European Parliament hosted by The Greens–European Free Alliance (Greens–EFA) and Progressive Alliance of Socialists & Democrats (S&D). On 1 July, a sequel, "TTIP and beyond – trade in global and local politics", was also held in the Parliament.

ANEC gave its views on standardization under TTIP in all three events. We stressed that standards should be seen, not only as TBTs, but also as elements of consumer protection when linked to legislation. We noted risks that a recognition of equivalence between European standards and "standards developed in the US" could bring, arising from the profound asymmetries between the ESS and the US standards model; and concluded that the only viable approach would be to work case-by-case.

In June 2015, ANEC contributed to, and supported, the CEN-CENELEC position paper on the risks of mutual recognition⁵.

ANEC at the 20th Consumers International (CI) World Congress

The 20th Consumers International (CI) World Congress⁶, dedicated to the theme 'Unlocking Consumer Power: A new vision for the global marketplace', took place in Brasilia, Brazil from 18-21 November 2015. The congress included panel sessions and interactive discussions across a range of important consumer issues, with experts from across the consumer movement, civil society organizations, government and the private sector. Jens Henriksson, of the Swedish Consumers' Association and Swedish member of ANEC's General Assembly, spoke on panels on standards and consumer protection, including ANEC's experiences at European level.

2. Child Safety

Laundry detergent capsules

ANEC supported the OECD – EC global awareness raising campaign on laundry detergent capsules which took place in March 2015. These products can be attractive to children and pose a serious danger if not handled and stored safely. ANEC asked its members to spread the message of the campaign. ANEC also spread the word via Facebook, Twitter and LinkedIn, and through the ANEC Newsletter. The posting on the ANEC Facebook page was seen by 50.224 people and attracted 257 "likes". ANEC also continued to follow ASTM work on the same subject through teleconference meetings, with a view to a possible proposal to CEN.

⁵ CEN-CENELEC paper 'The risks of mutual recognition of voluntary industry standards within the context of a future EU-US trade agreement (TTIP) and alternative approaches, <http://tinyurl.com/j34rs93>

⁶20th Consumers International (CI) World Congress, <http://goo.gl/9sPMJN>

Toys - lower limits for chemical compounds

ANEC welcomed the opinion of the EC Toy Safety Committee on 8 June 2015 to include new limit values in Appendix C of the Toy Safety Directive for formamide and the sensitizers, CMI, MI, CMI/MI 3:1 and BIT. The new values were established by the EC's Subgroup on Chemicals in Toys, in which ANEC participates. The Subgroup was created in 2010 – in answer to a request of ANEC and several Member States – to make proposals for improving the chemical requirements of the Toy Safety Directive. During the second half of 2015, the draft amendments of the Toy Safety Directive regarding formaldehyde, CMI, MI, BIT and formamide received a positive opinion by the MS. This is a great success for ANEC. The Directives to amend Appendix C of the TSD for formamide, CMI and MI were published in the OJEU⁷ on 24 November 2015.

New standard for domestic trampolines

In March 2015, ANEC issued the press release 'Jumping safely into spring: new safety standard for trampolines'⁸ to mark the referencing in the OJEU of EN 71-14:2014 "Safety of toys – Part 14: Trampolines for domestic use" (ANEC-PR-2015-PRL-002). In the press release, we welcomed publication of the standard and urged parents and other family members to buy only trampolines that comply with it. We stressed that despite publication of EN 71-14, a revision would be needed to address remaining issues, such as in-ground trampolines. In June, CEN TC 52 sent out a call for experts to participate in the work for in-ground trampolines, and ANEC nominated one.

New standards for domestic swimming pools

ANEC welcomed the adoption of three European standards for domestic swimming pools during the first half of 2015. The standards in the EN 16582 series deal with general requirements, as well as separate, specific requirements for in-ground and above-ground pools. During the second half of 2015, ANEC also welcomed the adoption by CEN of EN 16713, a further series of three standards for domestic swimming pools addressing requirements and test methods for filtration, circulation and treatment of water systems. ANEC participated in the drafting of all six standards calling for their adoption when they were circulated for the Formal Vote of national standards bodies. Further work on domestic swimming pools is continuing in the responsible technical committee, CEN TC 402, with the drafting of standards for mini-pools, spas and hot tubs. We also participate in this work.

First standard for moveable goals adopted

Several years ago, ANEC expressed concern about fatalities and serious injuries that can arise when children are accidentally hit by moveable goalposts. As a result, CEN started work on EN 16664 "Playing field equipment — Lightweight goals — Functional, safety requirements and test methods". The standard was adopted in April 2015. EN 16664 is one of two standards: CEN TC 136 WG22 is

⁷ Official Journal of the European Union

⁸ ANEC press release 'Jumping safely into spring: new safety standard for trampolines', <http://goo.gl/CifTY0>

also developing EN 16579 "Playing field equipment — Portable and fixed goals — Functional, safety requirements and test methods".

Progress on revision of playground equipment standards EN 1176

In February, ANEC commented on revision of four parts of the playground equipment standard EN 1176 which were out for enquiry. ANEC participated in two meetings of CEN TC136 SC1 WG13 'Playground Equipment and Surfacing, Revision of Safety requirements', to deal with the resolution of the comments received during the enquiry of prEN 1176-1 "Playground equipment and surfacing - Part 1: General safety requirements and test methods". ANEC sent 52 comments on prEN 1176-1, of which more than 90% were accepted; either for inclusion in the draft for formal vote, or for future work.

Chair mounted seats

At the January meeting of the EC Consumer Safety Network, ANEC expressed concern about age restrictions for lateral protection in EN 16120:2012 + A1:2014/prA2 'Child use and care articles — Chair mounted seat'. The draft mentioned lateral protection up to only 18 months, which is in conflict with EU Commission Decision (2013/121/EU) on safety requirements for certain seats for children. ANEC sent a lobbying pack and background paper with comment to DG JUST & CSN members in February. ANEC also submitted this comment during the enquiry of EN 16120:2012 + A1:2014/prA2 'Child use and care articles — Chair mounted seat'. During the second half of 2015, ANEC's main comment on lateral protection was accepted. ANEC therefore gave support for CEN TC 252 document N1363, Decision 390 to launch EN 16120+A1+prA2 'Chair mounted seats' to Formal Vote. The decision was adopted and the Formal Vote is now awaited.

Safety of cigarette lighters

ANEC welcomed adoption of the revised European Standard, EN 13869 "Lighters — Child resistance for lighters — Safety requirements & test methods" by CEN, having participated in the revision of the standard.

One main change incorporated into the revision is the option to use a mechanical test for piezo lighters as an alternative to child panel testing. This method can be used only for this type of lighter, as they on button-force to be child-resistant, whereas other types rely on more than one action, making them difficult to test mechanically. A second change is an amendment to the protocol for child panel testing to allow "sequential testing". Through this method, lighters can be tested using fewer children – potentially as few as 30 instead of the previous panel of at least 100 children.

EN 13869 was published on 29 March 2016. The references of the new EN 13869 will be published in the OJEU to give presumption of conformity to the General Product Safety Directive.

In addition to the revised EN for child resistant cigarette lighters, ANEC also supported the revised draft prEN ISO 9994 'Lighters — Safety specification' (ISO/DIS 9994:2015), out for CEN Enquiry until 15 January 2016. The main change that ANEC proposed to ISO in January 2015 — the lowering of the flame height — is included in the latest draft.

New standard for finger-protection devices

ANEC welcomed adoption of EN 16654 “Child protective products — Consumer fitted finger protection devices for doors — Safety requirements and test methods”. The standard was prepared by CEN PC 398 ‘Child protective product’ with participation from ANEC. Injury data from the German IDB (Injury Database), collected between 2006 and 2012, showed that — for children under one year of age — doors and door thresholds were involved in 80% of accidents where the children crushed their fingers or hands. For the age group 1-4, doors were involved in 38,6% of the cases, and for 42,6 % of the cases in the age group 5-14 years. EN 16654 is the second standard developed by CEN PC 398, following the publication in 2013 of EN 16281 “Child protective products — Consumer fitted child resistant locking devices for windows and balcony doors — Safety requirements and test methods’. CEN PC 398 started its activities following a research project commissioned by ANEC with proposals to develop standards for child protective products designed for attachment to other domestic products (e.g. child protective window locking devices, socket protectors, hob guards and locking devices for drawers and cupboard doors). CEN PC 398 is now working on a European standard for consumer fitted child resistant locking devices for cupboards and drawers.

European Seminar on Child Injury Prevention, 14 October 2015, Milan

On 14 October, EuroSafe hosted the seminar ‘Child injury Prevention: a European Challenge’ in Milan. The one-day event was organised with the European Public Health Association (EUPHA). This aimed to support action on child safety at both national and local level; to advocate for adoption and implementation of evidence-based good practices; and to increase and improve the capacity of professionals in health and other sectors relevant to child injury. ANEC spoke on “Products in a child’s sleep environment: Baby nests and sleep positioners”. There are no European standards for these, to which we think several hazards are related. Several supportive reactions were received following ANEC’s presentation. In 2016, the Child Safety WG will consider asking for a standard to be written for these products.

ANEC endorses Toy Safety Tips from TIE

Children learn through play, and toys make an essential contribution to their development. In December, with the festive season approaching, ANEC was pleased to endorse a short video⁹ prepared by Toy Industries of Europe (TIE) which includes 12 simple tips to help children play safely with toys. The video is available in English, Dutch, French, Italian & Spanish. Danish & German versions followed. A leaflet¹⁰ was issued to accompany the video. ANEC cascaded the toy safety tips to its network and promoted the video & leaflet on its social media sites.

⁹ Safety First – Top Tips for Toys (video), <http://goo.gl/b2rpuk>

¹⁰ Safety First – Top Tips for Toys (leaflet), <http://goo.gl/4cMf96>

PROSAFE launches market surveillance actions on acoustic toys and on safety barriers

In September, ANEC participated in the kick-off meetings of two new PROSAFE joint market surveillance actions on children's products. During the next two years, market surveillance authorities, Member States & EFTA countries will cooperate to target non-compliant child safety barriers and acoustic toys. ANEC attended the kick-off meetings and made a presentation at each.

With respect to acoustic toys, ANEC believes the acoustic requirements of EN71-1:2011+A2:2013 should be more stringent as children are a vulnerable consumer group. Major problems lie with impulse sound from toy cap guns and similar toys, as one exposure to excessive impulse noise can cause irreversible hearing disorders. As the acoustic requirements of the EN are complicated, ANEC proposed an audiologist or other specialist participate in the market surveillance action.

Regarding child safety barriers, ANEC stressed the importance of clear instructions for use, as faulty installation will lead to high risk situations. Although not in the current European standard, ANEC opinion is that where a safety barrier is mounted at the top of a staircase, it should be positioned so that the barrier does not open directly on to the stairs. As EN 1930 will soon be reviewed, ANEC asked PROSAFE to identify elements of the standard that are difficult to apply or where the wording is not clear enough.

ANEC will continue to follow these joint actions as stakeholder.

ANEC study sees possible improvements in drafting standards

The ANEC technical study 'the development of safety requirements and hazard-based standards for child use and care articles'¹¹ has been finalised. Safety requirements, incorporated into the standardization requests directed to CEN and CENELEC, are a key element in the development of new standards under the General Product Safety Directive (GPSD). They need to follow a hazard-based approach that completely and systematically identifies, assesses and addresses hazards and risks.

The levels of safety in safety requirements should be relevant to the significance of hazards and risks; especially when the risk of harm is high. These levels of safety should be defined by the EC's GPSD committee, not left to CEN-CENELEC to decide, as the role of the latter is to find ways of addressing safety requirements, not to decide on their significance.

These are two of the conclusions of the ANEC technical study, which was undertaken by the Child Accident Prevention Trust in the UK.

To support the development of safety requirements, the study presents a hazard and risk matrix, drawing heavily on the table in CEN/TR 13387:2015, *Child use and care articles — General safety guidelines — Part 1: Safety philosophy and safety assessment*.

¹¹ ANEC technical study 'the development of safety requirements and hazard-based standards for child use and care articles', <http://tinyurl.com/j3rwq17>

The study also recommends that:

- CEN/TR 13387-1:2015 should be amended in line with recommendations presented in the report to assist the drafting of informative rationales in standards.
- After publication, a standard should be audited by the expert panel that drafted the safety requirements to determine whether it fulfils the requirements, both in terms of completeness and levels of safety provided. This determination should be undertaken systematically using proposals presented in the report. This can be made easier by drafting safety requirements and standards in a hazard-based format.
- The expert panel responsible for drafting safety requirements should have broad representation from key stakeholders to ensure members have an understanding of all the issues to be addressed.

Although the report focuses on standards developed under the GPSD, and for products with which children may interact, the principles could be extended to products for adults and those falling under other Directives.

ANEC position paper on Formaldehyde in toys

Noting the work of the subgroup on chemicals, established under the EC's Toy Safety Expert Group, ANEC presented its draft position paper on formaldehyde to the February meeting of the subgroup, including a proposal for limits covering all relevant exposure routes (skin contact, oral exposure & inhalation) to be included in Appendix C of the Toy Safety Directive.

The final version of the position paper¹² is available on ANEC's website. The paper discusses possible limits for formaldehyde for toys intended for use by children under 36 months, or in other toys intended to be placed in the mouth, taking into account food contact material legislation to be inserted in Appendix C (Article 46) of the Toy Safety Directive.

It recommends to adopt:

- for textile components of toys, a limit of 30 mg/kg when tested in accordance with EN ISO 14184-1 in line with the current requirement included in EN 71-9 unless a REACH restriction is adopted with a similar level (currently subject of a public consultation);
- for paper components of toys, a limit of 30 mg/kg when tested in accordance with EN 645 and EN 1541 in line with the current requirement included in EN 71-9;
- for formaldehyde as a preservative, an exclusion based on a LOQ;
- for formaldehyde used as a monomer, a limit of 1,5 mg/l (expressed as amount of substance per litre of simulant in the aqueous migrate prepared in accordance with EN 71-10);
- for formaldehyde emissions from resin-bonded wood components of toys, the requirement to use wood based panels complying with requirements equivalent to the E1 classification of wood-based panels as defined in the relevant European standards.

¹² ANEC position paper on Formaldehyde in toys, <http://tinyurl.com/hu4s4km>

Discussions on the limits proposed by ANEC will continue at the next meeting of the subgroup in June 2016.

ANEC position paper on Aniline in toys

In parallel to its position paper on formaldehyde, ANEC also submitted a position paper¹³ on aniline in toys. Aniline has been classified as a (suspected) non-threshold carcinogen, i.e. a substance which should not be present in toys. The paper discusses the need for an aniline limit for toys intended for use by children under 36 months or in other toys intended to be placed in the mouth, taking into account food contact material legislation.

It reviews existing regulatory and normative provisions including available test methods. The document provides evidence on the occurrence of aniline in articles intended for children identified by test magazines and other reports showing that aniline has been found at levels up to 1200mg/kg in articles for babies (using methods to determine primary aromatic amines after reductive cleavage).

It is recommended to adopt for aniline:

- a limit of 30mg/kg for toy articles made of textile and leather in line with REACH provisions for carcinogenic primary aromatic amines released from azo colourants including any "free" aniline;
- corresponding test methods given in EN ISO 17234-1 for leather and EN 14362-1 for textiles adapted to detect aniline;
- the application of the provisions included EN 71-7 on finger paints (i.e. 10mg/kg for the "free" aniline and 30 mg/kg for aniline cleaved from azo dyes) for all liquid toys

It further recommends to consider:

- a broadening of the proposed limit toy articles made of textile and leather to other materials
- to initiate a broader discussion on colourants and related substances in toys

Anthropometric data of children

CEN is carrying out an EC-funded project to acquire updated anthropometric data of children in Europe. The first stage of the project was to identify needs and gaps in terms of application of anthropometric data in design and standardization of child products (i.e. toys, childcare articles, furniture, playgrounds, clothing, sport goods and facilities, and child restraint systems). A questionnaire was put online to collect information. Although ANEC fully supports this EU funded project, it was not entirely clear to us why the need was identified to prioritise by product sector. We believe there is an equal need for up-to-date anthropometric data for children, independent of the category of products. For instance, using the example of the head size of a 2 year boy, we would assume the same size is used, irrespective of whether it would be for use in work on playground

¹³ ANEC Position Paper: Aniline - Proposed requirement for Appendix C of the Toy Safety Directive, <http://tinyurl.com/grdqyhp>

equipment, pushchairs or another product. Our opinion is reflected in a letter responding to the questionnaire.

ISO/IEC Guide 50 ‘Child safety and standards – General guidelines’

The revised version of ISO/IEC Guide 50 ‘Safety aspects — Guidelines for child safety in standards and other specifications’ was published in December 2014 and welcomed by ANEC.

In its report to IEC ACOS (Advisory Committee on Safety) in November 2015, ANEC and Consumers International requested ACOS to promote the value and use of ISO/IEC Guide 50 ‘Safety aspects — Guidelines for child safety in standards and other specifications’ in IEC standards committees and working groups.

ANEC comments on the revision of ISO/IEC Guides 41 & 14

In March 2016, ANEC submitted comments on ISO/IEC Guide 41 ‘Packaging — Recommendations for addressing consumer needs’. We commented that the safety of flexible plastics packaging intended for single or repeated use, which is likely to be accessible to children in the home and may pose suffocation risk, should be carefully considered in the Guide. In this respect, we noted to CEN/TR 16353:2012 ‘Packaging — Safety guidelines for flexible plastic packaging to minimize the risk of suffocation to children’. Furthermore, we stressed tactile warning symbols should be included on all hazardous (and non-hazardous) packaging as a matter of course, also in relation to the means of opening.

Concerning the revision of ISO/IEC Guide 14 ‘Product information for consumers’, we sent comments to strengthen the positioning of services and vulnerable consumers in the Guide.

3. Design for All/Accessibility¹⁴

ANEC influences European Standardization on Design for All (M/473)

CEN and CENELEC accepted standardization mandate M/473 with the aim of ensuring accessibility is addressed in all relevant standardization initiatives. ANEC supported the mandate and aids its execution. The Chair of the ANEC Design for All WG is active in CEN/BT WG 213 ‘Strategic Advisory Group on Accessibility’ (SAGA) & CEN/CLC JWG 5 “Design for All”.

Among the many deliverables to be prepared under M/473, three background reports and a proposal for a standard were considered by the Technical Boards of CEN and CENELEC in the first half of 2015. CEN/BT approved a report describing a process to identify the relevance of standardization deliverables for people with disabilities & older persons (Deliverable 1.1); a further report describing the main areas of standardization to be reviewed in addressing the needs of people with disabilities & older persons’ (Deliverable 1.2) and work plan setting priorities and a time schedule for addressing accessibility (Deliverable 2.1). However, the CENELEC/BT expressed a negative opinion and did

¹⁴ The title of the ANEC Design for All WG has been changed to Accessibility WG in 2016.

not approve the work item proposal for a new standard, “Accessibility following a Design for All approach in products, goods and services – Extending the range of users”.

During the second half of 2015 and into 2016, the two Technical Boards maintained a dialogue with a view to reaching a solution on whether a European Standard (EN) or Guide should be developed on Design for All. ANEC continued to press for an EN, but the CENELEC community showed strong preference for a Guide.

At the meetings of the Technical Boards of CEN and CENELEC in February 2016, the two BTs confirmed their willingness to follow the Design for All approach, but decided to develop a Technical Specification (TS), ‘Accessibility following a Design for All approach in products, goods and services – Extending the range of users’, within JWG 5 as a first step.

Although welcoming the commitment of CEN-CENELEC to improve accessibility, we regret the lack of ambition to pursue an EN in the first instance. We now look to the EC to decide how the execution of M/473 should continue.

ANEC leads ETSI work on use of mobile ICT devices by people with cognitive disabilities

ETSI Special Task Force STF488, on the identification of the functional needs of people with learning disabilities — including dyslexia, dementia & other cognitive impairments — when using mobile ICT devices, was set up following an ANEC proposal. ANEC experts were selected to contribute to the STF.

A workshop was held on 2 September 2015 to develop recommendations on how mobile technologies can benefit people with cognitive disabilities. ANEC attended the workshop where end users were present and a strong case was made that the work should not focus on diagnostics of disabilities but on the common limitations of functionalities faced by people with disabilities. However, once the details of the STF approach were fully understood, this negative reaction turned to a strong endorsement of the approach. Nine groups of cognitive disabilities have been identified, but it was agreed to focus on functionalities limitations.

Two deliverables are being developed by Special Task Force (STF 488): – A Technical Report identifying the needs of people with cognitive disabilities when using mobile devices and Guidelines for designers of mobile devices. ANEC is contributing to both documents.

Touch screens in lifts

ANEC is working on the revision of EN 81-70 "Safety rules for the construction and installation of lifts — Part 70: Accessibility to lifts for persons including persons with disability". The revision is being carried out by CEN TC 10 WG 7 ‘Accessibility to lifts for persons including persons with disability’, set up following an ANEC request.

At the end of 2014, a proposal was made to use touch-screen technology in lifts. The main reason for this development is the velocity of management of lift groups, which can be accelerated by this solution. ANEC notes that none of these solutions has been tested sufficiently with the relevant user groups of blind, partially sighted and elderly people. Alerted by ANEC, the European Blind Union, the European Disability Forum and other national disability associations also expressed a negative

opinion on the technology. Negative comments were also submitted by the national standards bodies of Denmark and Sweden.

After a demonstration of the use of lifts by people with visual impairment, organised by ANEC & EBU, a new approach was agreed by WG 7, applicable only for destination controls in lobbies of huge office buildings with groups of lifts.

PrEN 81-70:2015 was out for CEN enquiry until 29 January 2016. ANEC supported the submission of the draft to enquiry. During the finalisation of the draft, we sent comments in liaison with the European Blind Union (EBU) and the European Disability Forum (EDF), especially on the use of touch screens, some being taken into account. In December, we sent a positive lobbying request to our General Assembly members with additional comments.

CENELEC ends work on the use of appliances by vulnerable consumers

On 30 November & 1 December, CENELEC TC 61 WG4 held its last meeting to deal with work under Mandate M/392 and revision of the EN 60335 series for electrical household appliances to address use by vulnerable consumers.

The previous version of the EN 60335 standards contained an exclusion or limitation clause that these standards do not "..., in general, take into account the use of appliances by young children or infirm persons without supervision."

In 2003, ANEC argued successfully that the clause was discriminatory, leading to the creation of CENELEC TC 61 WG 4 to revise the standards. Due to the complexity of European legislation governing domestic electrical appliances, and need to ensure safety and accessibility, the revision process proved complex and time consuming. ANEC provided financial support to determine the technical solutions needed to facilitate the revisions.

The task of WG4 has now come to an end. The culmination of work represents a huge step forward for the safety of European consumers, especially children, older people & those with disabilities.

EC study on consumer vulnerability

In February 2016, the EC published the study, 'Consumer vulnerability across key markets in the European Union'¹⁵. The study follows the EC's European Consumer Consultative Group's Opinion on consumers and vulnerability¹⁶, drafted by ANEC and BEUC¹⁷ further to ANEC's position paper on Vulnerable Consumers of December 2011. The Opinion aims to provide a better understanding and increased consideration for all consumers' needs, to develop an inclusive and targeted policy approach by the EC.

¹⁵ 'Consumer vulnerability across key markets in the European Union', <http://tinyurl.com/h86amvf>

¹⁶ European Consumer Consultative Group's Opinion on consumers and vulnerability, <http://tinyurl.com/zun2goc>

¹⁷ The mainstream European consumer organisation www.beuc.eu

The EC study looks into the difficulties consumers face in getting the best or fairest deals. It identifies the main reasons behind this vulnerability and considers what can be done to enable consumers to make better use of their rights and the alternatives the marketplace offers.

Speaking at the London Energy Forum on 23 February, European Commissioner for Justice, Consumers & Gender Equality, Věra Jourová, said *"Today we still don't have a lot of reliable information on consumer vulnerability. It is this knowledge gap that separates us from an effective policy response. We need a single, EU-wide definition of consumer vulnerability"*.

ANEC hopes the study will help the EC develop the right legislative, policy and standardization approach to address consumer vulnerabilities. We are ready to contribute to this important task.

4. Domestic Appliances (DOMAP)

Standardization request on ethanol stoves

On 6 February, ANEC replied to the consultation of stakeholders on a standardization request for alcohol-powered flue-less fireplaces ("ethanol stoves"). We supported the request as these products are associated with several hazards. The standardization request was adopted at the Committee on Standards (CoS)¹⁸ meeting on 7 October 2015, in line with the ANEC position. Also in October, ANEC gave support for draft CEN BT C123/2015 'Final draft standardization request in the field of alcohol-powered flueless fireplaces'. CEN accepted the standardization request, which was published by the Commission on 24 November 2015 (M/538).

Draft safety requirements for barbecues

DG JUST proposed updates to the rolling plan for standardization under the General Product Safety Directive. Following consultation of the Consumer Safety Network, and the contributions of Member States and ANEC, DG JUST proposed to set up draft safety requirements for barbecues, solid fuels & firelighters (among other products). ANEC nominated an expert to help the EC in setting safety requirements for these products, and contributed to the first version of the draft requirements for barbecues in May. The work is related to the dangers of the indoor use of barbecues, which can cause carbon monoxide poisoning. At the end of December, the draft safety requirements were updated and circulated to CSN members and observers for comment, reflecting the ANEC proposals. ANEC sent its written support to DG JUST.

PROSAFE launches market surveillance action on power tools

In September, ANEC attended the kick-off meeting of the PROSAFE Joint Action on power tools (e.g. drills, grinders, circular saws) and made a presentation. The main areas for ANEC are the balance between performance and safety; hot surfaces of non-functional parts; legibility of warnings

¹⁸ The committee of EU Member States established under Regulation (EU) 1025/2012 on European standardization. ANEC is an observer.

& markings; and migration of professional tools into consumer hands. ANEC will follow this joint action as a stakeholder.

Real-life use of vacuum cleaners

On 16 December, ANEC participated in a workshop on meaningful and consumer relevant test methods to simulate real-life use of vacuum cleaners. The workshop was hosted by CECED, the European Committee of Domestic Equipment Manufacturers. It was a chance for stakeholders to exchange information, knowledge, wishes and ambitions on the future development of vacuum cleaners and discuss possibilities of revising standards to reflect consumer behaviour better.

ANEC, and other consumer representatives present, asked that the tests of cleaners be done to reflect real-life use and noted that manufacturer declarations on the energy label are not always consistent with tests done by consumer organisations. It was recognised that future legislation and standards – should take into account consumer behaviour as far as possible.

The results of the workshop will be sent to CENELEC TC59X WG6 to aid its future work.

Electric toys

FprEN 62115 and IEC 62115/Ed2 ‘Electric toys – Safety’ were out for parallel voting in CENELEC (Formal Vote) and in IEC (CDV) until 13 May 2016. During the enquiry in 2015, Consumers International (CI) and ANEC submitted one comment concerning access to batteries, which was accepted. ANEC, CI and COPOLCO also successfully supported Annex J, related to the safety of remote controls for electrical ride-on toys. As a result, ANEC submitted support for FprEN 62115 to CENELEC and for IEC 62115/Ed2 to IEC and sent a lobbying request to members. CI and ISO COPOLCO also sent out lobbying requests to support the adoption of the new standard.

5. Digital (Information) Society¹⁹

Smart cities meeting consumer needs

In January, we supported the approval of the final report of the CEN-CENELEC-ETSI Smart and Sustainable Cities and Communities Co-ordination Group (SSCC-CG) and its recommendations to the Technical Boards of CEN and CENELEC.

Recommendation 12, on citizen issues related to smart cities, was drafted by ANEC, noting that citizen welfare is often stated to be central to the smart city concept, yet no effort seems to be made to assess its implications.

We proposed smart citizen-related requirements, including accessibility issues, and a data protection/privacy Technical Report was added as an additional specific action to the SSCC-CG new

¹⁹ The title of the ANEC Information Society WG has been changed to Digital Society WG in 2016.

Terms of Reference. The proposal was also taken on board in the EC ICT Rolling Plan for standardisation 2016.

ANEC submitted a proposal for the SSCC-CG report on citizens' requirements for smart cities. We believe there should be a brief introduction on how the report is drafted, i.e. what are the subjects included, how each issue is treated. Other sections should cover the standards' aspects of citizens' day-to-day interfaces with their local authorities and with their local service providers respectively.

We further suggested that citizens' general needs should cover certain "horizontal" matters that affect daily life including: citizen involvement/empowerment, complaint & redress procedures; physical security; cyber-security; data protection, privacy; and accessibility, both physical and electronic.

Our proposal, welcomed by SSCC-CG, also reflects the feedback received by the EIP-SCC Cluster on "Citizen Focus". The work should continue in 2016.

ANEC questions whether smart meters and grids benefit consumers

Mandate M/490 on smart grids was closed in early 2015. We found the execution of M/490 to be mostly positive but criticised issues related to implementation, notably on provision of energy consumption information, the lack of interoperability between end-devices and privacy.

We welcome that the EC analysed the status of interoperability and implementation of smart meter functionalities at national level. While most Member States foresee to implement smart meter functionalities of importance to consumers, work on interoperability still needs to be done.

The EC also included ANEC's proposal to monitor the success of smart metering from the consumer perspective into the report's recommendation. We had proposed measures that could be used to assess whether the smart meter deployment is truly benefitting consumers, namely by monitoring if consumers: (1) have easy access to usable consumption information, (2) have a high level of satisfaction with smart metering deployment, (3) are able to realise benefits from smart meters and (4) are engaged in the smart energy market.

Standards work on privacy by design at a stalemate

ANEC regrets no agreement seems possible amongst the members of CEN-CENELEC JWG 8 on a work programme to respond to Mandate M/530 on privacy by design. Although the concepts of privacy-by-design and privacy-by-default are now being embedded in the EU General Data Protection Regulation, standardizers appear unable to address the issue. Under the new Regulation, data protection safeguards should be built into products and services from the earliest stage of development, and privacy-friendly settings should be by default (e.g. on social networks or mobile apps). ANEC believes standards should be key in complementing legislation and believe an opportunity is being lost.

ANEC Guides on privacy standardization

On 29 January 2015, to mark International Privacy & Data Protection Day (the anniversary of the signature of the Council of Europe Convention on Data Protection in 1981), ANEC released guidance to help consumer representatives in standards committees address personal data protection²⁰:

- ANEC Pocket Guide “*Overview of Privacy Guidance for Consumer Representatives in standards technical committees. Key Principles*”
- ANEC Pocket Guide “*Overview of Privacy Guidance for members of standards technical committees who are Consumer Representatives: Key Principles for Digital Device Privacy Impact Assessment*”
- ANEC Pocket Guide “*Using Consumer Data: Consumer Representatives Guide on Privacy*”

In April, ANEC published a fourth guide: *ANEC Pocket Guide for Representatives “Using Consumer Data. Data transfer, trading and privacy”* and, in June 2015, a fifth guide: *ANEC Consumer Representatives Guidance “Domestic privacy and the privacy of digitally connected devices”*.

They were presented at the ISO/COPOLCO workshop, “The Connected Consumer”, in May and sent to CEN/CLC JWG 8 “Privacy management in products and services”.

In July 2015, ANEC issued a Consumer Privacy Standards Coordination report aimed at over-viewing the preliminary work to examine the coordination issues associated with standards for consumer privacy, and consumer representatives’ activity under way in UK, in Europe and Internationally in ISO.

ANEC suppresses flame retardants for audio-video equipment

IEC TC 108 proposed transformation of the Technical Specification, IEC TS 62441 ‘Safeguards against accidentally caused candle flame ignition’, into an IEC standard and CENELEC standard. A parallel vote was held in IEC and CENELEC in March 2015. We were pleased to see IEC 62441/Ed1 rejected as it contained a controversial external ignition provision on use of flame-retarding chemicals. We believe protection against external ignition must be reached without flame-retardants that may be hazardous to people or the environment. Resistance against external ignition can be achieved by design (e.g. sandwich construction) or use of materials (e.g. ceramics).

²⁰ ANEC pocket guide, 'Using Consumer Data. Data transfer, trading and privacy', <http://tinyurl.com/gg92pqt>

ANEC pocket guide, 'Domestic privacy and the privacy of digitally connected devices', <http://tinyurl.com/prh7os5>

ANEC pocket guide, 'Overview of Privacy Guidance for Consumer Representatives in standards technical committees. Key Principles', <http://tinyurl.com/opo7hu6>

ANEC pocket guide, 'Overview of Privacy Guidance for members of standards technical committees who are Consumer Representatives: Key Principles for Digital Device Privacy Impact Assessment', <http://tinyurl.com/nuesbxr>

ANEC pocket guide, 'Using Consumer Data: Consumer Representatives Guide on Privacy', <http://tinyurl.com/zi96kqb>

ANEC commented on IEC/EN 60065-A1Ed8: Audio, video and similar electronic apparatus – Safety requirements, and IEC 62368-1-A1/Ed2: Audio/video, information and communication technology equipment – Part 1: Safety requirements, out for parallel voting (IEC/CENELEC) until mid-October 2015. The revision proposed the inclusion of the candle flame test. ANEC noted in its comments that the proposed text went against consensus reached in IEC/CENELEC regarding the issue of flammability test, confirmed at the beginning of this year with the negative voting results on IEC 62441/Ed1.

Nevertheless, the voting result was negative. Both standards were rejected in IEC and CENELEC. This was a very important achievement for ANEC and we trust that the discussion on candle flame test for TV sets is settled once and for all.

We also contributed to revision of IEC 62368-1, '2nd Edition, Audio/video, information & communication technology equipment' and supported the drafts of IEC 60990/Ed3 'Methods of measurement of touch current and protective conductor current', IEC 60950-22/Ed2 'Information Technology Equipment – Safety – Part 22: Equipment to be installed outdoors' and IEC 62911/Ed1 'Audio, video and information technology equipment – Routine electrical safety testing in production' (ANEC-ICT-2015-G-027). The drafts were accepted to proceed in IEC and CENELEC, in line with our position.

The improvements to IEC 62368-1 'Audio/video, information and communication technology equipment – Part 1: Safety requirements' will be reflected in a new 3rd edition. Several new proposals are included, such as temperature limits of touchable parts of wearable devices of 43 degrees as proposed by Anec. Two other important issues covered are FIW wires (zero defect wires) and test requirements for wireless charging requirements.

ANEC supported the parallel vote on FprEN 60950-22:2015 "Information technology equipment – Safety – Part 22: Equipment to be installed outdoors and FprEN 62911:2015 "Audio, video and information technology equipment – Routine electrical safety testing in production". Both standards were approved in line with ANEC's position.

Taking into account how consumers really use mobile phones

France made a Formal Objection under Directive 1999/5/EC to EN 50566:2013 on requirements to demonstrate compliance of radio frequency fields from handheld and body-mounted wireless communication devices used by the general public (30MHz - 6GHz) Measurements showed more than 84% of devices included a recommendation of the manufacturer or the importer to use the equipment at a distance of 15 mm at least between the body and the device. 90% of the devices measured by the French Authorities conformed to the threshold of 2 W/kg when the measurements were performed at 5 mm from the body and not in contact. However, the measurements showed that SAR levels measured in contact of the rear surface of the device often exceeded the threshold of 2 W/kg fixed by the Recommendation n° 1999/519/EC, and sometimes even exceeded the value of 4 W/kg.

France considered necessary that the current standards related to "body SAR" measurements should be revised so that the manufacturer cannot choose a distance perhaps incompatible with the reasonably foreseeable use of the equipment, in line with new Directive 2014/53/EU on radio equipment, and especially its Article 17.1.

ANEC had similar comments in 2011 when prEN 50566 was discussed by CLC TC 106x. Unfortunately, our comments were not accepted and ANEC expressed regret during the vote on the standard. We supported the Formal Objection and urged CENELEC to revise the standard as soon as possible. The Commission suggested the publication of a restrictive warning in the Official Journal, which ANEC supported. It is expected the draft decision/Formal Objection will be adopted beginning 2016.

6. Services

M/517 on Horizontal service standards

The EC approved the report of the CEN Strategic Advisory Group on Services (SAGS) on implementation of Phase 1 of M/517 on the programming and development of horizontal service standards in May 2015.

The report identified six topics for the development of horizontal standards: Service terminology; Information to the client (before, during or after service provision); Service procurement; Agreement-service contracts (B2B/B2C); Service review- performance measurement; Service review-customer satisfaction measurement. Of these, the EC has asked three be developed in Phase 2: Performance measurement, Service contracts, Service procurement.

Although it is clear that any new services standards will be focused on the business need and interest, there are several aspects of consumer interest in the prioritised topics and ANEC's position on services standards in response to CEN's survey undertaken under the framework of the implementation of the Mandate (M/517) on horizontal service standards²¹ was well considered. This will need to be followed up in the second phase of the mandate.

On 2 June, ANEC joined the Conference – Single Market in Service (ANEC-SERV-2015-G-027), hosted in Brussels by DIN, at which the German Standardization Roadmap for Services²² was presented. This roadmap was developed by German stakeholders under DIN leadership. Following up also on work done in CEN SAGS AHG on Mapping of services standards, it divides the German services sector into 18 areas so that concrete recommendations for action can be made for each.

ANEC attended the CEN SAGS meeting on 20 November 2015 in Paris where we intervened on our expected paper on the Commission Communication on Upgrading the Single Market (COM (2015) 550) and the intention to follow the work of the new TC on public procurement.

ANEC participated in the AFNOR-CEN symposium – “Which tools to support the development of services?” in Paris on 19 November – where participants agreed on the need for continued awareness raising and success stories to be transferred whether on sector or country basis.

²¹ANEC position on services standards in response to CEN survey undertaken under the framework of the implementation of the Mandate (M/517) on horizontal service standards, <http://goo.gl/Nh3sgu>

²² <http://goo.gl/34mTDf>

As part of the second phase of the mandate 517 implementation the new CEN TC 447 'Services – Procurement, contracts and performance assessment' has been set up and tasked to develop standards in response to Mandate M/517 on horizontal services standards. ANEC will nominate a representative in the TC.

ISO COPOLCO WG 18 on Services

ANEC participates in the recently-created ISO COPOLCO WG 18 on Consumer issues in Services. The WG is revising ISO/IEC Guide 76, *Development of service standards – Recommendations for addressing consumer issues*. ANEC joined the WG meeting in March 2016 and is helping to revise the Guide, considering useful aspects of CEN Guide 15 on services standards and the activities at European level.

CEN TC 445 'e-Business Processes in the Insurance Industry'

In summer 2015, DIN put forward a proposal to create a new TC 445 to develop standards in electronic business processes and relevant data in the European insurance industry. This includes especially the development of unique process models for policy administration and claims handling. Standardization will focus on the processes, which connect insurance companies with their customers and their market partners. ANEC follows the work although of only indirect relevance to consumers.

ANEC on CEN-CENELEC Health Care strategy

ANEC has a leading role in developing a CEN-CENELEC strategy for service standards in healthcare. We spoke at the JRC-CEN-CENELEC-EARTO Workshop 'Putting Science into Standards Evidence-based quality assurance – an example for breast cancer'²³ in October (ANEC-PT-2015-HGS-008), on our expectations for the development of a European quality assurance scheme for breast cancer services. We presented our experiences in the development of European standards for healthcare & social care and the concerns we managed to address in existing standards.

Online reviews

In light of the growing digitalisation of services, and with a particular view on consumer experience in the tourism sector, ANEC participates in ISO TC 290 WG 1 dealing with online reviews.

Two meetings were held in the first part of 2015 with the first draft of the standard reflecting many ANEC comments. Our Representative also attended (web) meetings held in the second part of 2015 and in 2016 when she also joined the new Project Team on Guiding Principles and the Editing Committee of ISO TC 290.

²³ JRC-CEN-CENELEC-EARTO Workshop on 'Putting Science into Standards Evidence-based quality assurance – an example for breast cancer', <https://goo.gl/19F63u>

Postal services

The “Keep Me Posted” campaign, supported by ANEC, is gaining more support from European organizations and MEPs in its call to maintain at least parallel access to certain documents through the traditional post, as well as online access. Meanwhile, CEN TC 331 WG 1 accepted our comments on TS 15472, intended to measure transit time for cross-border parcels using “Tracking & Tracing”. FprCEN/TS 16819 ‘Postal services – Parcel boxes for end use – Technical features’ also reflects the comments ANEC submitted.

Barriers to clicking cross-border

Only 10% of EU consumers regularly shop from internet retailers in other EU countries, compared with 63% from websites in their home countries, according to our survey of more than 4'000 consumers in 22 EU countries.

ANEC’s technical study ‘European cross-border online shopping – Learning from consumer experiences’²⁴ reveals that, despite EC policies to encourage e-commerce cross-border, consumers still face notable barriers to reaping the benefits of a digital single market.

The study looks at the online shopping habits of EU consumers and identifies key problems met by those who buy from internet retailers in other EU countries.

Two-thirds of online shoppers surveyed have bought cross-border, with 15% finding a problem. Of these, 27% reported late deliveries while 22% said their orders never arrived. Respondents also reported problems trying to place orders, such as unfair price differences, unclear or misleading information, and retailers refusing to sell or deliver to the address of the shopper.

An overview of findings can be found in the ANEC leaflet: *Key Facts on Cross-border online shopping within the EU*²⁵.

7. Sustainability

ANEC’s concerns with candle emissions

ANEC recommends stricter requirements on candle emissions in indoor air²⁶. Our proposals refer to the draft Commission decision on the safety requirements to be met by European standards for candles, candle supports, containers & accessories further to the GPSD. We are concerned current provisions may adversely affect human health. We are also concerned about the leeway open to business in the standardization work.

²⁴ ANEC technical study ‘European cross-border online shopping – Learning from consumer experiences’, <http://goo.gl/DKk6VP>

²⁵ ANEC leaflet: Key Facts on Cross-border online shopping within the EU, <http://goo.gl/4gmi6T>

²⁶ ANEC recommends stricter requirements on candle emissions to the indoor air, <http://goo.gl/kxiEti>

As a minimum, ANEC believes strict and detailed requirements must be set which reflect the proposals concerning chemical requirements and emission values put forward in our recommendations.

Sustainable development - standardization in Sweden and Europe

The Swedish Standards Consumer and Workers' Council 'SKA-rådet' invited ANEC to speak at its event, "Tools for sustainable development – standardization in Sweden & Europe" on 6 October in Stockholm. The Swedish consumer association and Swedish consumer agency are part of the SKA-rådet which aims to include empowering user participation in standardization through non-profit organizations.

ANEC presented its role and how its key activities contribute to sustainable living. We illustrated the work we do in sustainability with examples of best practice. Speakers agreed on the difficulties encountered by societal stakeholder organizations in standards committees but also highlighted benefits of participating – provided fair and proper representation is achieved. The event discussed strengths and weaknesses of the national delegation principle of the European Standardization System, and the importance of collaboration at national, European, and international levels to achieve sustainable standards that reflect societal interests.

Reporting CSR

ANEC replied²⁷ to an EC public consultation on non-binding guidelines on methodology for reporting non-financial information.

The purpose of this consultation was to collect views from stakeholders on non-binding guidance for certain large companies across all sectors following article 2 of Directive 2014/95/EU on the disclosure of non-financial and diversity information.

ANEC calls for disclosure statements to especially report impacts of the company's activity and for the assessment of company performance to be compared with others through benchmarks. It is also important for a company to establish sustainability requirements on its suppliers and to inform consumers.

If the guidelines do not make detailed provisions, leaving a free choice to companies, the comparability needed to enforce the directive will not be achieved.

We stress that, although certain existing frameworks may be used as source of inspiration, it is vital to establish a European set of indicators addressing a range of sustainability topics. We recommend such indicators partly be taken from EU Best available techniques Reference documents (BREFs) and EMAS sector reference documents. Inspiration can also be taken from ISO 14031 on environmental performance evaluation.

A European approach to corporate accountability reporting should therefore be started with guidelines for non-financial reporting.

²⁷ ANEC answer to EC Public consultation on non-binding guidelines on methodology for reporting non-financial information, <http://tinyurl.com/jr67o73>

8. Traffic

CI/ANEC proposal on lateral-facing ECRS adopted

CI/ANEC alerted experts in the UNECE Informal Group on ECRS to two issues in the text of Regulation R129 (setting out requirements for Child Restraint Systems (CRS) or “child seats”): the unintended exclusion of lateral-facing Enhanced CRS (ECRS) and unclear wording. A CI/ANEC proposal, addressing both issues, was adopted.

CI/ANEC attended the 165th session of UNECE WP 29 where an amendment was adopted to prohibit the use of Y-shaped harnesses in other than rearward and lateral-facing CRS. This was fast-tracked under pressure from CI/ANEC.

UNECE Regulation 129 – important progress

GRSP, the expert group in UNECE addressing requirements for CRS made important progress in its 59th meeting (9-13 May 2016). It agreed on the draft text of the 2nd phase of Regulation 129 (the ‘i-Size Regulation’), which is expected to be operational mid-2017. The second phase deals with enhanced CRS for bigger children – secured with the car’s seat belt – in booster seats. Under the new regulation, they benefit from side impact protection until a stature of 135cm. CI/ANEC welcomes the decision as, although the phase 2 proposal could be improved further, it represents a major improvement over previous requirements.

Separately, CI/ANEC proposed withdrawal of requirements for integral Isofix CRS from the old Regulation 44, in order to avoid confusion in the marketplace and the sale of CRS offering lower levels of safety than the new Regulation 129. GRSP decided to agree to our request with an effective date of 1 September 2017.

Child seats for bicycles

ANEC attended the second meeting of CEN TC 252 WG 7 ‘Child cycle seats’ on 28-29 October 2015. We successfully raised several issues of consumer relevance, i.e. to carry out the risk assessment based on CEN/TR 13387, which was agreed. This was also the major comment from ANEC defending the need for revision of EN 14344 ‘European Standard for Child Seats for Bicycles’. Additionally, we argued in favour of environmental testing (UV, corrosion, aging of materials) and raised the compatibility between child seat and luggage carrier as well as the fixing of the seat. It was decided to establish liaison with ISO/TC 149/SC 1 “Cycles”, further to liaison with CEN/TC 333 to ensure dovetailed requirements and avoidance of conflict. The ANEC representative was appointed liaison officer.

Light electric vehicles

ANEC participated in the two meetings of CEN TC 354 WG 4 in 2015 to contribute to work on a standard for light electric vehicles. The ANEC representative won several key points in the drafting, including the inclusion of redundant safety functions in the case of malfunction or shutdown, active lighting, pedestrian protection, and limits on load and speed. The ANEC comments on prEN xxx-1:2013.2 ‘Light electric vehicles and self-balancing vehicles’ were taken into account.

ANEC continued contributing to the work in CEN TC 354 WG 4 in the second half of 2015. A plenary held on 1 September 2015 was attended by ANEC. Its goal was to discuss the allocated tasks of the last meeting as well as the received comments – most of them submitted by ANEC. The “July” version of the draft was still immature. Basic issues, such as definitions, normative structure, figures and requirements were confused. The ANEC representative commented substantially on both technical and editorial items. Most comments were accepted.

ANEC contributes to standards work on fuel labelling

With the increasing number of alternative fuels for cars, consumers are sometimes confused as to what type of fuel can be used. A European Commission mandate asked CEN to develop a European standard on fuel labelling, taking into account the directive on deploying alternative fuels infrastructure (2014/94/EU). CEN TC 441 was created and tasked to make sure the standard to ensure relevant, consistent and clear information is made available for those vehicles that can be regularly fuelled with the individual fuels in the market. Since the summer, ANEC has attended three meetings of CEN TC 441 to define a single standard covering all fuels that would avoid misfuelling. The intention is to have a standard by November 2016. ANEC participates in the work.

Call for Juncker to reinstate serious road injury target

A long-promised strategic target to reduce serious road injuries was dropped from an EC review of the region’s road safety policy published in June 2015. ANEC – as well as more than 70 experts, representatives of road safety organisations & victims groups from across Europe – joined MEPs in sending a letter to EC President Juncker urging him to reverse the decision. The injury target had been supported by Member States and Parliament. More than 200’000 people suffered life-changing injuries in road collisions in 2014, an increase of 3% on the previous year.

ANEC contribution to survey on noise of L-category vehicles

ANEC replied²⁸ to a survey, ‘Enhanced sound requirements for L-category vehicles, i.e. mopeds, quads and their replacement silencers’. The study aimed at identifying whether UN Regulations fit the EU context. Particular emphasis was given to tools to enable market surveillance and enforcement of relevant legislation. ANEC believes that the noise of L-category vehicles poses a problem in rural as well as urban areas, but especially in cities. Tampering with silencing systems is a main cause of noise pollution. ANEC asked for better legislation and enforcement, as well as improved market surveillance.

²⁸ ANEC response to Questionnaire on Enhanced sound requirements for L-category vehicles, i.e. mopeds, quads and their replacement silencers <http://goo.gl/r2gSPs>

9. Communications in 2015

ANEC Position Papers

21 ANEC Position Papers²⁹ were published during the year. Each was posted on ANEC's website and linked to social media (Facebook, Twitter, LinkedIn).

ANEC e-Newsletter

10 editions³⁰ of our e-Newsletter were published in 2015. Each was posted on ANEC's website and linked to social media (Facebook, Twitter, LinkedIn). A link was emailed to almost 900 subscribers.

Annex:

- ANEC's suggestion for a COPOLCO resolution on the removal of the "exclusion clause" and lower surface temperature limits in the IEC 60335 series of standards on the safety of electrical household and similar appliances

²⁹ ANEC Position Papers, <http://goo.gl/9J3ljf>

³⁰ ANEC Newsletters, <http://goo.gl/Tv1oZm>



ANEC suggestion for ISO COPOLCO resolution on removal of “exclusion clause” and lower surface temperature limits in IEC 60335 series of standards on safety of electrical household and similar appliances

COPOLCO passed **Resolution x/2016**:

COPOLCO,

Refers to its Resolution 21/2015 (Plenary) on safety of household appliances for all consumers (removal of the “exclusion clause” in IEC 60335 series of standards)

Thanks Mr. Arnold Pindar (ANEC President), for the report about ANEC activities and in particular for its efforts in removing the “exclusion clause” in EN 60335 series of standards on safety of electrical household and similar appliances,

Notes the progress made by IEC TC 61 “Safety of household appliances” on the issue of surface temperature levels of household appliances, which is of particular importance for older consumers and children,

Encourages COPOLCO members to continue to support the IEC TC 61 revision of the relevant IEC 60335 series of standards on safety of electrical household and similar appliances, based on the work done in CENELEC in order to take into account the needs of vulnerable consumers, and to encourage IEC TC 61 to accelerate the process of adopting surface temperatures limits for IEC 60335 Parts 2 in line with IEC Guide 117:2010 ‘Electrotechnical equipment – Temperatures of touchable hot surfaces’.



International Organization for Standardization
Organisation internationale de normalisation
Международная организация по стандартизации

**AGENDA ITEM 16.5 DEVELOPMENTS OF CONSUMER INTEREST IN
THE ASIA-PACIFIC MEMBERS OF COPOLCO**



AGENDA ITEM 16.5 REPORT ON ASIA AND PACIFIC ISLAND COUNTRIES' CONSUMER PARTICIPATION IN STANDARDIZATION (AP COPOLCO)

Table of Contents

Introduction.....	1
1. Awareness of the importance of standards among the general public (schools, women, etc)....	2
2. Education in standardization.....	3
3. (Comparative) testing of consumer products or reviews of consumer services which have influenced standards development in your country.....	5
4. Capacity building activities (training, workshops etc) for consumer interest representatives (consumer organizations, consumer protection agencies, societal organizations etc).....	6
5. Research on the need of consumers in relation to standards and conformity assessment.....	8
6. Specific issues and challenges faced and how ISO (and ISO COPOLCO) can help.....	9

Introduction

Between **May 2015 and March 2016** the activities undertaken by AP COPOLCO members are categorized as:

1. Increasing awareness of the importance of standards
2. Providing education in standardization
3. Testing consumer products
4. Capacity-building
5. Resolving issues they face; and how ISO COPOLCO can help
6. Researching consumer issues and standards

Specific reports were received from Japan, Fiji, Thailand, Indonesia and Malaysia. Fiji has raised issues related to **Unit Pricing** on tissue products and has highlighted areas where the **ISO Central Secretariat could lend support**.

In this report there is a link to the first AP COPOLCO newsletter for your information.

1. Awareness of the importance of standards among the general public (school, women, etc.)

Japan

The Japanese Industrial Standards Committee (JISC) has recently published a JIS standard on washing symbols to harmonize the use of these symbols in Japan. This harmonization makes it easier for consumers in Japan to access information on washing their clothes and textiles.

Children being strangled by strings on their clothing was reported frequently especially in the EU. Japan has a JIS Standard on **Safety criteria of draw strings** which outlines, among others, whether strings are used, and the length of strings according to age and body part.

Awareness of these two standards was raised through various channels such as distribution of brochures / pamphlets and information to consumer representatives to further educate consumers on the benefits of these two standards.

(Note: there are no law currently in Japan making compliance to these two standards mandatory).

JISC is also revising JIS Standard S4803 (child resistance of cigarette lighters) and has adopted ISO/IEC Guide 50, *Safety aspects – Guidelines for child safety in standards and other specifications*.

Thailand

Thailand's Industrial Standards Institute (TISI) reports the following awareness raising activities among the general public, private and civil society, on the importance of standardization:

1. Standards training for community leaders and consumer groups, focusing on the importance and role of standards in the protection of consumer rights.
2. A "Training Led by Consultancy (TLC)" project for industry and relevant public and private agencies to help their management systems comply with international standards.
3. Capacity building programmes on management system standards to help industries enhance their knowledge and understanding and be kept to date with the current situation.
 - Training on the Requirements and Implementation of ISO/IEC 17025:2005, *General requirements for the competence of testing and calibration laboratories*, and ISO 14001:2004, *Environment Management Systems*.

Indonesia

The Indonesian Standards Body (BSN) organized an awareness session on the importance and benefits of Indonesian Standards (SNI) for food to small and medium enterprises on February 2016. Micro and household enterprises, mostly handled by housewives, are interested in implementing food safety standards. Session materials included principles of food safety standards and Good Manufacturing Practices (GMP). As a follow up, BSN will also conduct training and provide assistance for the implementation of ISO 22001, *Food Safety Management Systems*, to small and micro enterprises in May 2016.

As for increasing public awareness of the SNI, BSN organized education to the public through exhibitions and education games on SNI certified products. The event was held in commemoration of the annual National Technological Revival Day (HAKTENAS). Education on SNI includes competitions, puzzles and cooking using SNI compliant products.

Fiji

The Department of National Trade Measurement and Standards of Fiji (DNTMS) reported the following awareness-raising activities:

- i. Public Awareness in various designated forums (Government Service Centres, Agriculture Shows, Careers Expos @ Universities etc.). In addition, standards awareness is created when conducting enforcement on goods declared dangerous under Fijian law (according to the Trade Standards and Quality Control Decree 1992).
- ii. The ISolutions Webstore was used to promote ISO publications (ISolutions is managed by ISO). The Fijian Standards Catalogue is promoted on www.pasc.standards.org.au for national standards, and is managed by Standards Australia). The Trade Standards Advisory Council (on the board of the national standards body) also creates awareness and markets the use of international and national standards to the private sector.
- iii. The Fijian Building Standards Committee (FBSC) assisted in raising awareness on Fiji's National Building Code and other related Fijian Standards in the building sector.

Malaysia

General public awareness raising between May 2015 and March 2016 was scaled down. Standards Users is the first consumer organization appointed as a Standards Development Agency by Standards Malaysia. It now develops standards of consumer interest and manages the national mirror committee of ISO COPOLCO. It has recently completed Malaysia's Standard on Product Safety and Recalls. Two awareness and promotion sessions will target manufacturers and stakeholders in the consumer product supply chain.

2. Education in standardization

Thailand

TISI launched its project on standardization education in 2003 and from May 2015 – March 2016, the following activities were conducted:

- i. workshops on the integration of standardization into the primary school curriculum, to help teachers design teaching programmes effectively.
- ii. a contest, under project TIS Knight, allowing secondary school students to learn about standardization and keep on creating activities to disseminate their knowledge in their school.
- iii. a seminar to promote a curriculum on international standards on energy, environment, occupational health and safety, and standardization in vocational education.
- iv. A training course on Management System Standards for university students.

Indonesia

BSN is among the most active NSBs in the region on education in standardization. It has signed MOUs with over 30 institutes of higher learning in Indonesia.

BSN held the 1st National Standardization Competition for Senior High School Students, from May 12-13, 2015. This competition involved 44 teams from 30 schools to the shortlisting of 10 teams for the finals. Two winners were selected to participate at the 10th International Standards Olympiad in Korea, August, 6-9, 2015. The Indonesian team again won silver and bronze medals.

BSN has also developed an E-learning on Standardization and Conformity Assessment in 2015 (<http://elearning.bsn.go.id>). This contains teaching materials, animation, a flipbook, video presentation, examination and certificate of completion.

BSN has also developed a Distance learning system of Standardization and Conformity Assessment through web-based teleconference using ISO WebEx. This has been implemented in 12 universities as a pilot.

Bandung Institute of Technology has a Masters Programme on Standardization, a dual degree with Taiwan's National University of Science and Technology (NTUST); its first intake enrolled 22 Masters students.

Fiji

The Fiji National University (FNU) engages consultants/experts from overseas and provides week-long training sessions on Management System Standards such as ISO 9001, ISO 14001 and ISO 22000. The National Standard Body (NSB) and the FBSC work with FNU to teach students on Fiji's National Building Code (FNBC) and standards referenced in the FNBC. Further discussions are in the pipeline with Fiji's Higher Education Committee and tertiary institutes on this matter.

Malaysia

The annual SPEAK UP! programme for youth focuses on sustainable consumption of water and pollution prevention in light of several water supply crises in Malaysia.

Standards Users has also signed MOUs with University Technology Malaysia and two other MOUs are in the pipeline. In the scope of the MOU is promotion of standards as content for courses and as tools for young graduates in their new workplaces and entrepreneurial endeavours.

3. (Comparative) Testing of consumer products or reviews of consumer services which influenced standards development in your country

Indonesia

BSN Standards for Halal Management Systems are now being developed by the TC on Halal (03-08). These standards intend to provide comfort, security, safety, and the certainty of availability of halal products for consumers. Halal will increase the competitiveness of industries that produce and sell halal products

To collect the needs and expectations from the stakeholders of halal products, BSN held a focus group on halal management systems attended by consumers, producers, academia, and regulators.

Fiji

Fiji's DNTMS conducted tests on water quality (using an accredited lab). The water samples were obtained from seven mineral water companies in Fiji. The outcome of the tests showed compliance with Fijian standards for bottled water – and a Certificate of Production was issued to these companies. Review of the standard is being considered.

DNTMS also conducted inspections on plastic toys made of poly vinyl chloride (PVC). PVC toys containing Phthalate are declared dangerous in Fiji. Therefore, the Material Safety Data Sheets were collected from importers in Fiji and due diligence done. The outcome was favourable and importers are allowed to retail PVC plastic toys in Fiji if they comply with the relevant Fiji Standards. The list of goods declared dangerous is also being reviewed to strengthen border control.

DNTMS conducted due diligence on the Certificate of Compliance (CoC) for roofing coils. Importers & manufacturers have to apply for a licence to import roofing coils into Fiji and comply with the requirements of FS/AS 1562:1998. Importers/manufacturers have to submit third party accredited lab reports as per the Standard. CoC results were not favourable – leading to more stringent requirements for the importation of roofing coils into Fiji – which have been put in place.

In response to the devastating effects of tropical cyclone Winston all Fijian Building Standards are being reviewed.

Malaysia

In light of several complaints, Standards Users is exploring means and resources to test LED and CFL lights on 'suspicion' that the market is being flooded with sub-standard lighting products – defeating the purpose of emission reduction initiatives in the country.

4. Capacity building activities (training, workshops etc.) for consumer interest representatives (consumer organizations, consumer protection agencies, societal organizations etc.)

Japan

JISC, cooperating with consumer organizations, held seminars in about 18 locations (in 2014) attended in total by approximately 2'000 consumers. The seminars usually describe the standards, *Textiles-care labelling code using symbols* and *Safety of children's clothing-cords and drawstrings on children's clothing – Specifications*. The information was very welcomed by participants.

Thailand

TISI organized seminars on national standards for consumers to understand TISI's market surveillance mechanism, to increase consumer confidence in the quality of certified products.

Indonesia

BSN held a Consumer Participation Discussion Forum on October 11, 2015, to increase the capacity of consumers in its standardization activities. The keynote by the BSN Deputy of Information and Promotion of Standardization underlined the important role of the community in standardization and conformity assessment. Consumer participation in standardization activities includes new standard proposals, standards formulation and utilization, promoting standard quality, participation in fighting fraud in standard applications by reporting the cases to the ministry/LPNK, local governments, law enforcement agencies, and other related agencies. With the contribution of the public / consumers in standards development, standards produced will be relevant to consumer needs.

Fiji

Fiji formed a working group on Consumer Services in Standardization, chaired by the Trade Standards Advisory Council. ISO/IEC Guide 76, *Development of Service Standards – Recommendation for addressing consumer issues* will be looked into as well.

The purpose of establishing a WG is to seek comments from all service-based organizations/companies on improving consumers' experience with services in the Fijian marketplace. These views will be consolidated and put forward to the Fijian Committee on Consumer Policy (COPOLCO mirror committee) by the WG Chair of CSS.

The WG objectives will align to ISO's COPOLCO Working Group on Services:

- To promote awareness and understanding of standardization of services amongst consumers and consumer organizations;
- Promote understanding on the importance of consumer issues in standardization of services within ISO, amongst standard bodies and other standard stakeholders;
- Identify consumer issues and needs in standardization of services; and,
- To explore and address issues of consumer participation in standardization of services.

Fiji has formed a Steering Committee with members from the Ministry of Industry, Trade and Tourism (Chair); Fiji Commerce Commission (FCC); Fiji Revenue and Customs Authority (FRCA); and other relevant stakeholders. This steering committee was established in response to pursuing objectives of the Pacific Island Countries Standards and Consumers Network (PICSCN). Its first meeting is scheduled in May 2016.

Malaysia

The APEC SCSC proposal on ODR has been unsuccessful in securing funding from APEC's support fund.

5. Research on consumer need for standards and conformity assessment

Japan

In line with the 2016 ISO COPOLCO and TMB Joint workshop on services and ISO strategy on services, JISC has initiated research into standardization in services in December 2015.

Thailand

TISI has surveyed consumer satisfaction in products with the TISI Mark. The findings were helpful in developing TISI's strategic plan.

Indonesia

BSN's Centre for R&D in standardization researched standard development in nanotechnology in Indonesia to protect the domestic market from substandard nano products. The research was encouraged by the unavailability of Nanotechnology standards in Indonesia, and limited awareness around nanotechnology products.

Prior to implementing mandatory compliance with SNI 6128:2008, BSN has researched quality requirements, maximum contamination levels of chemicals, food additives, and potential national differences in SNI 6128:2008's technical requirements; taking safety, security, health and environmental conservation for consumer protection into account.

Fiji

Fijian authorities investigated misleading labelling on tissue based products – such as toilet paper, facial tissues, paper towels and napkins – found to be not labelled properly as per the Trade Measurement Pre-packaging Regulation. To solve this, stakeholder awareness on labelling requirements of pre-packed items (in the Trade Measurement Pre-packed Regulation) was organized. Market surveillance was carried out to gauge the need for the standard. Consumer advocates and consumer regulatory bodies were contacted to get their feedback as most complaints are lodged with them.

Malaysia

Standards Users has recently published a position paper on private vehicle safety; calling for better warranty laws.

6. Specific issues and challenges faced and how ISO (and ISO COPOLCO) can help

Indonesia

Indonesia supports the work of COPOLCO's Key Areas WG to develop a new activity template "to improve protection for vulnerable consumers through international standards".

Fiji

Fiji's DNTMS shared the following issues and recommended ways ISO / COPOLCO can help:

- ISO's regional office should carry out more events/trainings in this region particularly those related to consumer protection, policies, competition policies etc.
- Strengthening networks with other regional or international consumer protection agencies.
- Donor aid/financial assistance to engage subject matter experts in consumer protection especially in consumer protection laws.
- Technical assistance by international bodies for enforcement agencies and consumer advocate bodies of developing countries is highly welcomed.
- Assistance in establishing a National Project Portal on the ISOLutions webstore: Currently, Fiji does not have any NPP to sell national Standards. It is quite cumbersome using e-mails/letters to inform technical committee members on standards development processes/updates of TCs etc. For TC members and the public to comment on international or national standards, we need the NPP whereby everyone is able to access documents and comment on standards being developed / reviewed. Technical assistance in IT is highly needed as we lack human resources & experts.
- Having a portal with information on consumer complaints, laws, outcomes and other relevant links under one portfolio with the NSB. This would provide information to our importers and counterparts overseas on goods & services requirements in Fiji, concerns/issues on products/services, so it is not imported in Fiji. A one-stop information portal on consumer related aspects.

Malaysia

ISO and ISO COPOLCO should investigate issues on harmonizing testing standards for the performance of energy efficient lighting and explore opportunities for standards to address vehicle emission testing problems; a topic of global media attention since 2014.

ISO COPOLCO should invite regional consumer protection agencies to maintain liaison relationships with ISO COPOLCO.



**AGENDA ITEM 16.6 DEVELOPMENTS OF CONSUMER INTEREST
IN THE LATIN AMERICAN REGION: REPORT
BY A REPRESENTATIVE OF COPANT CT 153**



**AGENDA ITEM 16.7 DEVELOPMENTS IN THE AFRICAN ORGANIZATION FOR
STANDARDIZATION (ARSO)**



**AGENDA ITEM 17. WRITTEN REPORTS TO NOTE FROM OTHER
ISO BODIES OF CONSUMER INTEREST**



International Organization for Standardization
Organisation internationale de normalisation
Международная организация по стандартизации

AGENDA ITEM 17.1 CONFORMITY ASSESSMENT (CASCO)

AGENDA ITEM 17.1 REPORT FROM THE COMMITTEE ON CONFORMITY ASSESSMENT (ISO/CASCO)

COPOLCO ACTION: members are invited to note this report.

1. CASCO structure, plenary and workshop

- 1.1. At the end of December 2015, Lane Hallenbeck terminated his second two-year term as Chair of CASCO. CASCO Secretariat would like to thank him for his hard work and commitment. As of January 1st, CASCO welcomed its new Chair for the 2016-2017 term, Mr Mandla Franck Makamo (SABS).
- 1.2. The 31st CASCO Plenary, associated policy meetings and workshop will take place from 1-5 May 2016 in Dubai, United Arab Emirates.

2. Topical issues currently being addressed in CASCO

- 2.1. CASCO and COPOLCO have started collaborating on the issue of *ethical labelling*, as consumers get confused by the different labels they find in the market. This issue was initially raised by the COPOLCO representative at one of the CASCO/STAR meetings and it was agreed that CASCO and COPOLCO set up a joint working group (JWG) to:
 - research the landscape and use of ethical labels within and outside of ISO;
 - define existing best practices that could be considered as common for all types of ethical labels; and,
 - recommend to CASCO if a document on this topic would be necessary (e.g. guidance, informative brochure etc.)

A call for experts to participate in the JWG will be launched in the forthcoming months in both committees.

- 2.2. In December 2015, CASCO co-organized with IEC and ITU the WSC Workshop on Conformity Assessment, hosted by UNECE from 1-2 December 2015, at the Palais des Nations, in Geneva. The workshop included 4 panels and gathered some 130 industry representatives, government regulators and economic leaders, who confirmed their interest in building on the success of the workshop with similar events in the future.
- 2.3. Last year, CASCO launched an interactive online tool that introduces the basics of conformity assessment and the CASCO toolbox, explaining why and how conformity assessment can be used by regulators, providing concrete examples from various fields. This tool is publicly available on the [ISO website](#) and proved to be a valuable source of information for anyone looking for practical information on conformity assessment. CASCO is in the process of developing a similar deliverable addressing specifically the concept of Suppliers' Declaration of Conformity (SDoC).

A task group has been set up to develop this new part, which will become an additional chapter of the CASCO online tool.

- 2.4. An educational brochure identifying what should be considered when developing personnel certification schemes is in the final stages of editing before publication this year.
- 2.5. CASCO is compiling a FAQ document on what should be considered when deciding between a management system standard and a conformity assessment standard. The work is being carried out by a task group of the Chairman's Policy and Coordination Group (CPC) and the brochure will be published this year.
- 2.6. A project plan has been developed to organize a pilot Stakeholder Forum on conformity assessment. This forum will allow CASCO to engage with a broad range of stakeholders on key conformity assessment matters. The pilot will be held late in 2016, with a focus on the insurance sector. Based on the outcomes of the pilot *Forum*, possibly further forums will be organized once a year/every two years in different parts of the world.
- 2.7. CASCO has completed its eighth year of managing the ISO Survey of Certifications. The 2014 survey results have been published on the ISO website in September 2015: www.iso.org. This year the survey will be realized in-house.
- 2.8. The CASCO CPC, STAR and TIG held their second set of meetings in December with the next ones scheduled for May 2016. The IAF-ILAC-ISO Joint Strategic Group will also meet in May 2016 to monitor the implementation of its strategic plan.

3. On-going CASCO technical work

- 3.1. June 2015 saw the publication of:
 - ISO/IEC 17021-1, *Conformity assessment – Requirements for bodies providing audit and certification of management systems – Part 1: Requirements*;
 - ISO/IEC TR 17026:2015, *Conformity Assessment – Example of a certification scheme for tangible products*.
- 3.2. CASCO technical projects progressed by their respective working groups (WGs) include the development of the following documents:
 - ISO/IEC TS 17021-2, *Conformity assessment – Requirements for bodies providing audit and certification of management systems – Part 2: Competence requirements for auditing and certification of environmental management systems* (Revision at DIS stage);
 - ISO/IEC TS 17021-3, *Conformity assessment – Requirements for bodies providing audit and certification of management systems – Part 3: Competence requirements for auditing and certification of quality management systems* (Revision at DIS stage);
 - ISO/IEC TS 17021-9, *Conformity assessment – Requirements for bodies providing audit and certification of management systems – Part 9: Competence requirements for auditing and certification of anti-bribery management systems* (Development of a new TS, at DTS stage);

- ISO/IEC TS 17021-10, *Conformity assessment – Requirements for bodies providing audit and certification of management systems – Part 9: Competence requirements for auditing and certification of occupational health and safety management systems* (Development of a new TS, 1st meeting end of April);
- ISO/IEC 17011, *Conformity assessment – General requirements for accreditation bodies accrediting conformity assessment bodies* (Revision at CD2 stage);
- ISO/IEC 17025, *General requirements for the competence of testing and calibration laboratories* (Revision at CD2 stage);
- ISO 17034, *Conformity assessment – General requirements for the competence of reference material producers* (Transformation of the Guide 34:2009 into an international standard, ISO 17034 at DIS stage);
- ISO/TR 17028, *Conformity assessment – Example of a certification scheme for services* (WD stage).

3.3. At the last CASCO/CPC meeting the members agreed to set up a working group to survey the ISO landscape with regard to the terms "validation and verification" in the conformity assessment context and to formulate a recommendation to the CPC on the need to develop a generic CASCO document to cover those two activities. WG 46 has been set up to carry out this research and deliver its recommendation at the CPC meeting in May 2016.

4. Promotion of the CASCO Toolbox and 2014 workshops

4.1. In 2015, the CASCO Secretariat continued the promotion of the CASCO Toolbox and highlighted the importance of implementing well established and recognized conformity assessment practices at different events, among which:

- WHO TWG meeting, Geneva, 21-22 September 2015
- EASC meeting, Minsk, 17-18 June 2015
- BIPM, OIML, ILAC, ISO Quadripartite meeting, Paris, March 2015
- IAF and ILAC meetings, Frankfurt, April 2014 and April 2015

5. External representations and liaisons

5.1. CASCO maintains category A liaison with 22 international organizations, including IEC.

5.2. Over 2015, CASCO has established D liaison with 3 organizations, PEFC, ISEAL Alliance and WADA, in the framework of the revisions of ISO/IEC 17011 and ISO/IEC 17025 standards.

6. CASCO membership

6.1. As of April 2016 CASCO has 132 members, including 96 P-members and 36 O-members.



International Organization for Standardization
Organisation internationale de normalisation
Международная организация по стандартизации

AGENDA ITEM 17.2 DEVELOPING COUNTRY MATTERS (DEVCO)



AGENDA ITEM 17.2 REPORT FROM THE COMMITTEE ON DEVELOPING COUNTRY MATTERS (ISO/DEVCO)

COPOLCO ACTION: members are invited to note this report.

1 New Action Plan for developing countries approved by DEVCO

Further to the adoption of the ISO Strategy 2016-2020 by the General Assembly in September 2015, the ISO Action Plan for developing countries 2016-2020 was approved by DEVCO through a committee ballot in November 2015, and endorsed by Council in December 2015. The final document was distributed to the ISO membership and is available on ISO online.

A high number of DEVCO members participated in the committee ballot (80 votes cast out of a total of 98 possible votes) and expressed their support for the new Action Plan (72 votes in favour, none against and 8 abstentions).

As a result of the vote, the ISO Academy established a work plan of technical assistance and training activities for the first year of implementation of the Action Plan, and validated it through the outcome of a needs assessment survey conducted with DEVCO members. The purpose of the survey was to understand the type of support required by developing countries in relation to the focus areas of the new Action Plan, and to build a truly demand-driven work plan for 2016.

2 Structure and expected outcomes of the new Action Plan 2016-2020

The ISO Action Plan for developing countries 2016-2020 implements elements of the ISO Strategy 2016-2020 relating to developing countries. It is structured around the following elements: impact (long-term vision), key outcome (overall result), and five outcomes (changes or benefits). The five outcomes are defined as follows:

1. *Standardization has a recognized, effective role in support of public policies*
2. *National standards bodies' strategic capabilities strengthened*
3. *National standards bodies' capacity strengthened at the operational and technical levels*
4. *Increased involvement of ISO developing country members in international standardization*
5. *Coordination and synergies with other organizations and among projects implemented*

All technical assistance and training activities to be carried out under the Action Plan 2016-2020 will focus on achieving the above outcomes.

2.1 COPOLCO related activities on the 2016 work plan

An activity of specific interest to COPOLCO members planned under the Action Plan 2016-2020 is a regional workshop on consumer involvement focused at engaging consumers in standards development work.

Participation at the event, planned to take place in October 2016, is on invitation only and targets ISO members in Central and Eastern Europe as well as Central Asia.

3 Report on 2015 activities under the Action Plan 2011-2015

A special training session for COPOLCO members in developing countries was organized on 11 May 2015, in Geneva, Switzerland, followed by the opportunity to participate at the COPOLCO plenary and related events.

A total of 16 experts representing NSBs and consumer associations from five of the nine ISO regions were sponsored to attend the training, thanks to funding from the Swedish International Development Cooperation Agency (Sida).

As part of ARSO's 21st General Assembly, a seminar was organized on 14 August 2015 for all participants at the meeting. The objective was to raise awareness on various issues such as consumer participation in standards development, consumers and food safety, consumers and public services.

An outreach workshop on *Connecting with consumers – Empowerment through standards* was held in collaboration with Consumers International, on 18 November 2015 in Brasília (Brazil). A sponsorship was extended to experts from 29 developing countries to attend the workshop.

4 Membership of DEVCO and next plenary meeting

As of January 2016, 150 ISO members from developed and developing countries are members of DEVCO (100 P-members and 50 O-members). The 50th meeting of DEVCO will take place in Beijing (China) on Sunday 11 September 2016.

5 DEVCO Chair's Advisory Group (CAG)

The DEVCO CAG consists of eleven members; eight from developing countries and three from developed countries. Members of the CAG are chosen in a personal capacity by the DEVCO Chair, in agreement with the Secretary-General, for a two-year term, renewable once.

Chair: Dr Lalith Senaweera, SLSI (Sri Lanka)
Members: Mr Carlos Santos Amorim, ABNT (Brazil)
Mrs Fadilah Baharin, DSM (Malaysia)
Mrs Léna Dargham, LIBNOR (Lebanon)
Mr Damian Fisher, SA (Australia)
Mrs Eve Gadzikwa, SAZ (Zimbabwe)
Mr Chingis Kuanbayev, KAZMEMST (Kazakhstan)
Dr Gevorg Nazaryan, SARM (Armenia)
Mrs Carina Svensson, SIS (Sweden)
Mr Hiroo Wakai, JISC (Japan)
Dr Mkabi Walcott, SLSI (Saint Lucia)

Since the disbanding of the position of ISO Regional Liaison Officer (Council Resolution 44/2010), and the need to ensure adequate geographic representation, CAG members are selected evenly, to the extent possible, from the nine ISO regions. Currently, the position for Central and Western Africa remains vacant.



International Organization for Standardization
Organisation internationale de normalisation
Международная организация по стандартизации

AGENDA ITEM 18. ANY OTHER BUSINESS